

MEASUREMENTS & SENSORS (20A02503T)

LECTURE NOTES

III-B.TECH & I-SEM

Prepared by:

Mr. D. CHINNA DASTAGIRI, Assistant Professor

Department of Electrical and Electronics Engineering



VEMU INSTITUTE OF TECHNOLOGY

(Approved By AICTE, New Delhi and Affiliated to JNTUA, Ananthapuramu)

Accredited By NAAC, NBA(EEE, ECE & CSE) & ISO: 9001-2015 Certified Institution

Near Pakala, P.Kothakota, Chittoor- Tirupathi Highway

Chittoor, Andhra Pradesh-517 112

Web Site: www.vemu.org



JAWAHARLAL NEHRU TECHNOLOGICAL UNIVERSITY ANANTAPUR
(Established by Govt. of A.P., ACT No.30 of 2008)
ANANTHAPURAMU – 515 002 (A.P) INDIA

Dept of EEE

Course Code	MEASUREMENTS & SENSORS	L	T	P	C
20A02503T			3	0	0
Pre-requisite	MACHINES	Semester			I

Course Objectives:

- The basic principles of different types of electrical instruments for the measurement of voltage, current, power factor, power and energy.
- The measurements of RLC parameters using bridge principles.
- The principles of magnetic measurements
- The principle of working of CRO and its applications

Course Outcomes (CO): After completion of the course, the student can able to

CO-1: Able to Understand the working of various instruments and equipments used for the measurement of various electrical engineering parameters like voltage, current, power, phase etc in industry as well as in power generation, transmission and distribution sectors

CO-2: Able to analyze and solve the varieties of problems and issues coming up in the vast field of electrical measurements..

CO-3: Analyse the different operation of extension range ammeters and voltmeters, DC and AC bridge for measurement of parameters and different characteristics of periodic and aperiodic signals using CRO.

CO-4: Design and development of various voltage and current measuring meters and the varieties of issues coming up in the field of electrical measurements.

Unit – I: MEASURING INSTRUMENTS

Classification – Ammeters and Voltmeters – PMMC, Dynamometer, Moving Iron Types – Expression for the Deflecting Torque and Control Torque – Errors and their Compensation, Extension of range – Numerical examples

Digital Voltmeters-Successive Approximation, Ramp, and Integrating Type-Digital Frequency Meter-Digital Multimeter-Digital Tachometer.

Unit – II: MEASUREMENT OF POWER, POWER FACTOR AND ENERGY

Single Phase Dynamometer Wattmeter, LPF and UPF, Double Element and Three Elements, Expression for Deflecting and Control Torques; P.F. Meters: Dynamometer and Moving Iron Type – 1-ph and 3-ph Power factor Meters. Single Phase Induction Type Energy Meter – Driving and Braking Torques – Errors and their Compensation, Three Phase Energy Meter – Numerical examples

Unit – III: INSTRUMENT TRANSFORMERS, POTENTIOMETERS, AND MAGNETIC MEASUREMENTS

Current Transformers and Potential Transformers – Ratio and Phase Angle Errors – Methods for Reduction of Errors-Design Considerations. DC Potentiometers: Principle and Operation of D.C. Crompton's Potentiometer –Standardization – Measurement of unknown Resistance, Currents and Voltages. A.C. Potentiometers: Polar and Coordinate types- Standardization – Applications. Determination of B-H Loop Methods of Reversals - Six Point magnetic measurement Method – A.C. Testing – Iron Loss of Bar Samples – Numerical Examples

Unit – IV: D.C & A.C BRIDGES

Method of Measuring Low, Medium and High Resistances – Sensitivity of Wheatstone's Bridge – Kelvin's Double Bridge for Measuring Low Resistance, Measurement of High Resistance – 183 Page Loss of Charge Method. Measurement of Inductance - Maxwell's Bridge, Anderson's Bridge. Measurement of Capacitance and Loss Angle – DeSauty Bridge. Wien's Bridge – Schering Bridge – Numerical Examples

Unit – V:	CRO AND DIGITAL METERS
------------------	-------------------------------

Cathode Ray Oscilloscope- Cathode Ray Tube-Time Base Generator-Horizontal and Vertical Amplifiers – Applications of CRO – Measurement of Phase, Frequency, Current and Voltage Lissajous Patterns.
Capacitive and Inductive displacement sensors, Electromagnetism in sensing, flow, Level sensors, position and Motion sensors, pressure sensors and Temperature sensors

Textbooks:

1. A.K.Sawhney “Electrical & Electronic Measurement & Instruments” Dhanpat Rai & Co. Publications, 2007.
2. E.W. Golding and F.C. Widdis, “Electrical Measurements and measuring Instruments”, 5th Edition, Reem Publications, 2011.

Reference Books:

1. H. S. Kalsi, “Electronic Instrumentation”, 3rd Edition, Tata Mcgrawhill, 2011.
2. Reissland, “Electrical Measurements: Fundamentals, Concepts, Applications” –M.U, New Age International (P) Limited, 2010.
3. R. K. Rajput, “Electrical & Electronic Measurement & Instrumentation”, 2nd Edition, S. Chand & Co., 2nd Edition, 2013.

UNIT-I: MEASURING INSTRUMENTS

INTRODUCTION TO MEASURING INSTRUMENTS

1.1 Definition of instruments:

An instrument is a device in which we can determine the magnitude or value of the quantity to be measured. The measuring quantity can be voltage, current, power and energy etc. Generally instruments are classified in to two categories.

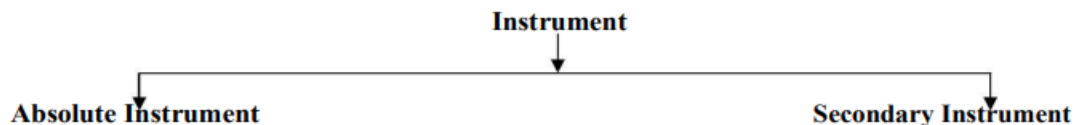

1.2 Absolute instrument

An absolute instrument determines the magnitude of the quantity to be measured in terms of the instrument parameter. This instrument is really used, because each time the value of the measuring quantities varies. So we have to calculate the magnitude of the measuring quantity, analytically which is time consuming. These types of instruments are suitable for laboratory use.

Example: Tangent galvanometer.

1.3 Secondary instrument

This instrument determines the value of the quantity to be measured directly. Generally these instruments are calibrated by comparing with another standard secondary instrument.

Examples of such instruments are voltmeter, ammeter and wattmeter etc. Practically secondary

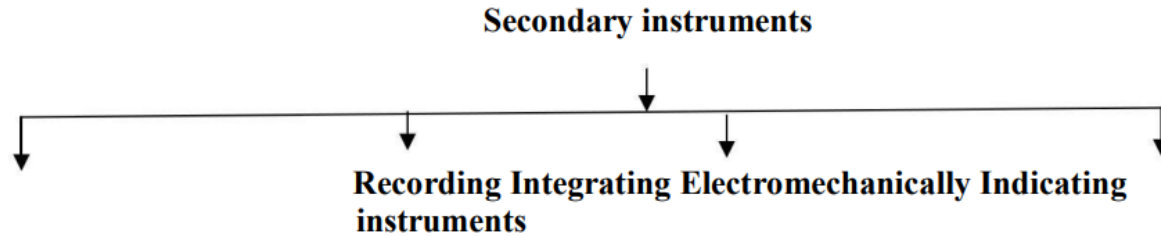

instruments are suitable for measurement.

1.3.1 Indicating instrument

This instrument uses a dial and pointer to determine the value of measuring quantity. The pointer indication gives the magnitude of measuring quantity.

1.3.2 Recording instrument

This type of instruments records the magnitude of the quantity to be measured continuously over a specified period of time.

1.3.3 Integrating instrument

This type of instrument gives the total amount of the quantity to be measured over a specified period of time.

1.3.4 Electromechanical indicating instrument

For satisfactory operation electromechanical indicating instrument, three forces are necessary. They are

- (a) Deflecting force
- (b) Controlling force
- (c) Damping force

1.4 Deflecting force

When there is no input signal to the instrument, the pointer will be at its zero position. To deflect the pointer from its zero position, a force is necessary which is known as deflecting force. A system which produces the deflecting force is known as a deflecting system. Generally a deflecting system converts an electrical signal to a mechanical force.

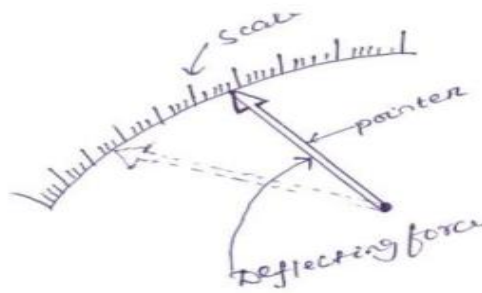

Fig. 1.1 Pointer scale

1.4.1 Magnitude effect

When a current passes through the coil (Fig.1.2), it produces an imaginary bar magnet. When a soft-iron piece is brought near this coil it is magnetized. Depending upon the current direction the poles are produced in such a way that there will be a force of attraction between the coil and the soft iron piece. This principle is used in moving iron attraction type instrument.

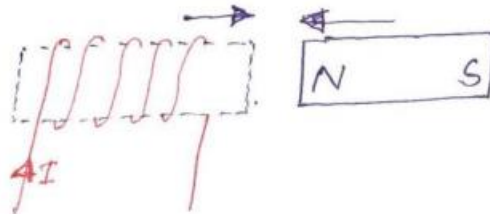

Fig. 1.2

If two soft iron pieces are placed near a current-carrying coil there will be a force of repulsion between the two soft iron pieces. This principle is utilized in the moving iron repulsion type instrument.

1.4.2 Force between a permanent magnet and a current-carrying coil

When a current carrying coil is placed under the influence of magnetic field produced by a permanent magnet and a force is produced between them. This principle is utilized in the moving coil type instrument.

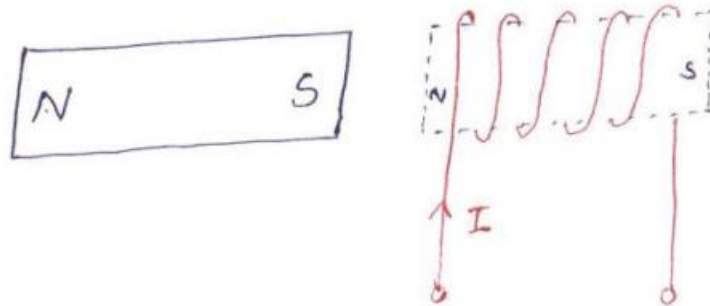

Fig. 1.3

1.5 Controlling force

To make the measurement indicated by the pointer definite (constant) a force is necessary which will be acting in the opposite direction to the deflecting force. This force is known as controlling force. A system which produces this force is known as a controlled system. When the external signal to be measured by the instrument is removed, the pointer should return back to the zero position. This is possibly due to the controlling force and the pointer will be indicating a steady value when the deflecting torque is equal to controlling torque.

$$T_d = T_c \quad \dots\dots(1.1)$$

1.5.1 Spring control

Two springs are attached on either end of spindle. The spindle is placed in jewelled bearing, so that the frictional force between the pivot and spindle will be minimum. Two springs are provided in opposite direction to compensate the temperature error. The spring is made of phosphorous bronze.

When a current is supply, the pointer deflects due to rotation of the spindle. While spindle is rotate, the spring attached with the spindle will oppose the movements of the pointer. The torque produced by the spring is directly proportional to the pointer deflection θ .

$$T_C \propto \theta \quad \dots\dots(1.2)$$

The deflecting torque produced T_d proportional to $'I'$. When $T_C = T_d$, the pointer will come to a steady position. Therefore

$$\theta \propto I$$

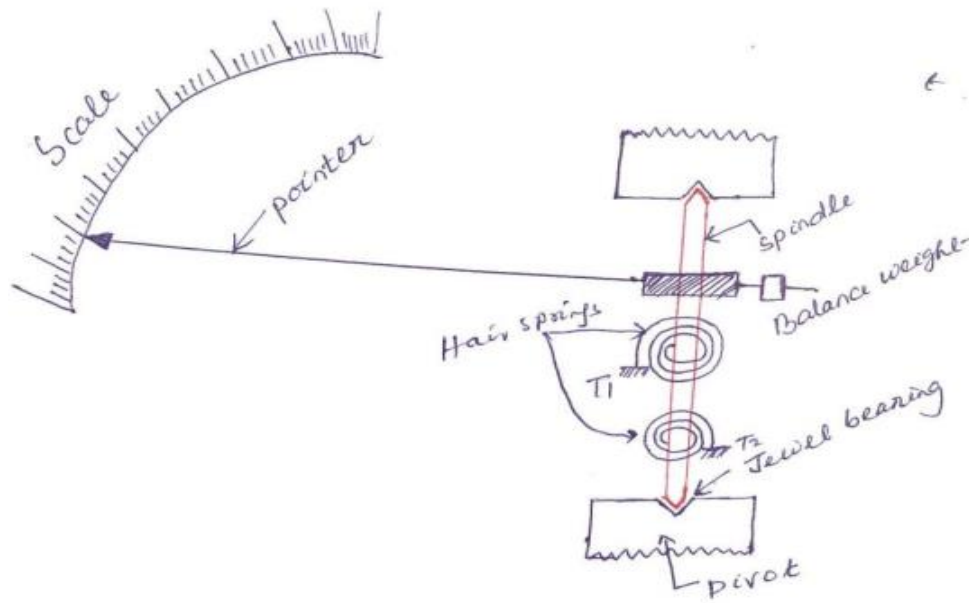

Fig. 1.5

Since, θ and I are directly proportional to the scale of such instrument which uses spring controlled is uniform.

1.6 Damping force

The deflection torque and controlling torque produced by systems are electro mechanical. Due to inertia produced by this system, the pointer oscillates about its final steady position before coming to rest. The time required to take the measurement is more. To damp out the oscillation quickly, a damping force is necessary. This force is produced by different systems.

- (a) Air friction damping
- (b) Eddy current damping

1.6.1 Air friction damping

The piston is mechanically connected to a spindle through the connecting rod (Fig. 1.6). The pointer is fixed to the spindle moves over a calibrated dial. When the pointer oscillates in clockwise direction, the piston goes inside and the cylinder gets compressed. The air pushes the piston upwards and the pointer tends to move in anticlockwise direction.

1.6.2 Eddy current damping

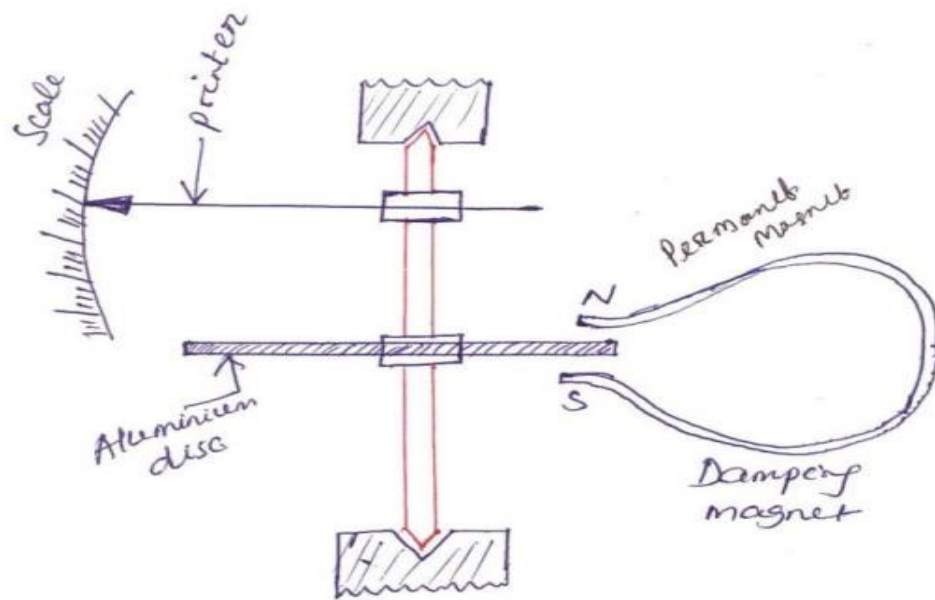
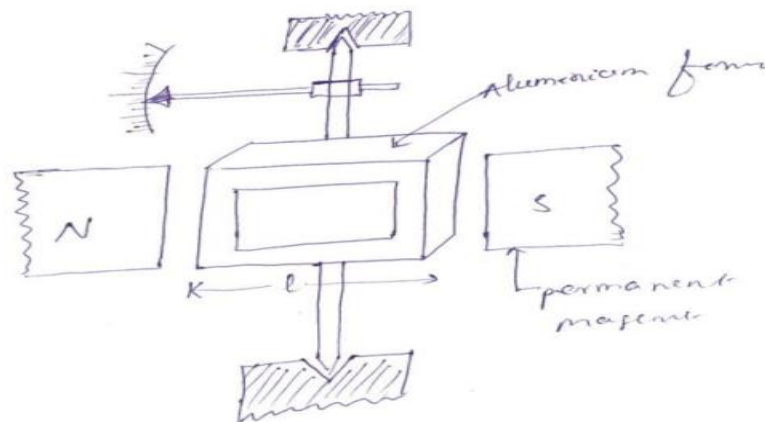

Fig. 1.6 Disc type

An aluminum circular disc is fixed to the spindle (Fig. 1.6). This disc is made to move in the magnetic field produced by a permanent magnet.

When the disc oscillates it cuts the magnetic flux produced by damping magnet. An emf is induced in the circular disc by faradays law. Eddy currents are established in the disc since it has several closed paths. By Lenz's law, the current carrying disc produced a force in a direction opposite to oscillating force. The damping force can be varied by varying the projection of the magnet over the circular disc.



1.7 Permanent Magnet Moving Coil (PMMC) instrument

One of the most accurate type of instrument used for D.C. measurements is PMMC instrument. Construction: A permanent magnet is used in this type instrument. Aluminum former is provided in the cylindrical in between two poles of the permanent magnet (Fig. 1.7). Coils are wound on the aluminum former which is connected with the spindle. This spindle is supported

with jeweled bearing. Two springs are attached on either end of the spindle. The terminals of the moving coils are connected to the spring. Therefore the current flows through spring 1, moving coil and spring 2.

Damping: Eddy current damping is used. This is produced by aluminum former. Control: Spring control is used

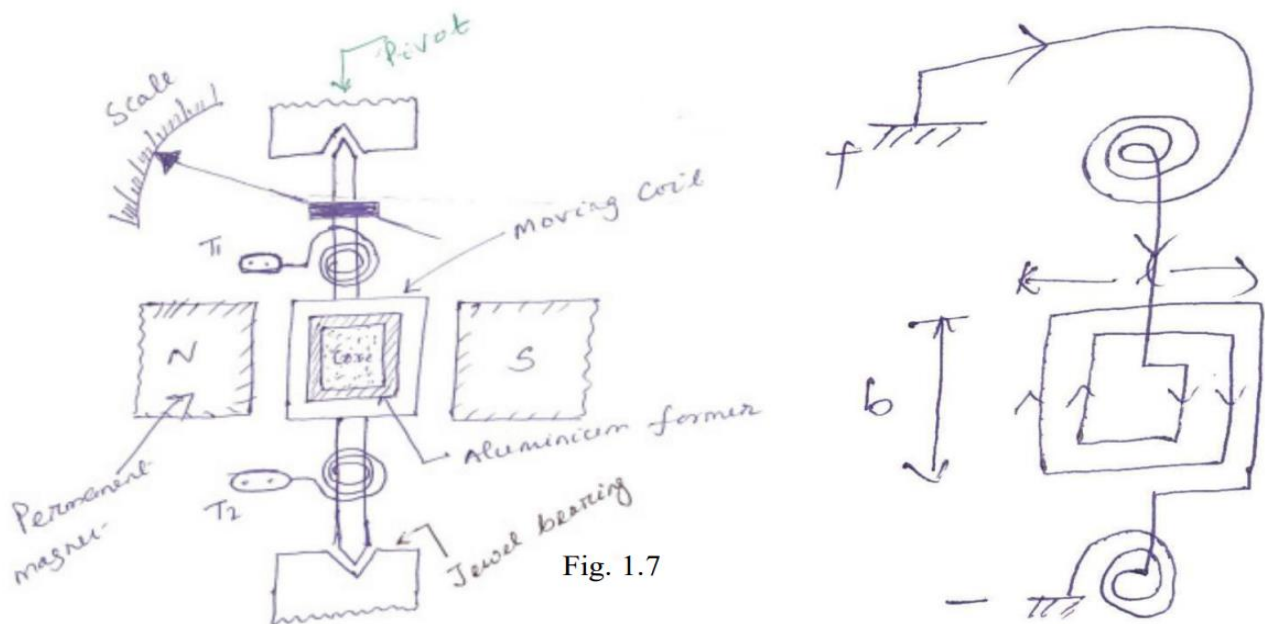

Fig. 1.7

Principle of operation

When D.C. supply is given to the moving coil, D.C. current flows through it. When the current carrying coil is kept in the magnetic field, it experiences a force. This force produces a torque and the former rotates. The pointer is attached with the spindle. When the former rotates, the pointer moves over the calibrated scale. When the polarity is reversed a torque is produced in the opposite direction. The mechanical stopper does not allow the deflection in the opposite direction. Therefore the polarity should be maintained with PMMC instrument.

If A.C. is supplied, a reversing torque is produced. This cannot produce a continuous deflection. Therefore this instrument cannot be used in A.C.

Torque developed by PMMC

- Let, T_d =deflecting torque
- T_C = controlling torque
- θ = angle of deflection
- K = spring constant
- B = width of the coil
- l =height of the coil or length of coil

N=No. of turns

I=current

B=Flux density

A=area of the coil

The force produced in the coil is given by

$$\mathbf{F = BIL \sin \theta} \quad \text{.....(1.4)}$$

When $\theta = 90^\circ$

$$\text{For N turns, } \mathbf{F = NBIL} \quad \text{.....(1.5)}$$

$$\text{Torque produced } \mathbf{Td = F \times \perp r \text{ distance}} \quad \text{.....(1.6)}$$

$$\mathbf{Td = NBIL \times b = BINA} \quad \text{.....(1.7)}$$

$$\mathbf{Td = BANI (1.8) Td \propto I} \quad \text{..... (1.9)}$$

Advantages

- Torque/weight is high
- Power consumption is less
- Scale is uniform
- Damping is very effective
- Since operating field is very strong, the effect of stray field is negligible
- Range of instrument can be extended

Disadvantages

- Use only for D.C.
- Cost is high
- Error is produced due to ageing effect of PMMC
- Friction and temperature error is present

1.7.1 Extension of range of PMMC instrument

Case-I: Shunt

A low shunt resistance connected in parallel with the ammeter to extend the range of current. Large current can be measured using low current rated ammeter by using a shunt.

Fig. 1.8

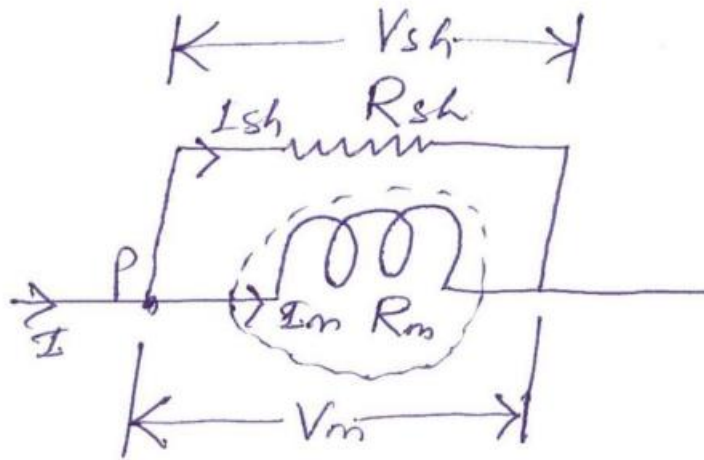

Let, R_m = Resistance of meter

R_{sh} = Resistance of shunt

I_m = Current through meter

I_{sh} = current through shunt

I = current to be measure

$$\therefore V_m = V_{sh}$$

$$I_m R_m = I_{sh} R_{sh}$$

$$\frac{I_m}{I_{sh}} = \frac{R_{sh}}{R_m}$$

Apply KCL at 'P' $I = I_m + I_{sh}$

Eqn (1.12) ÷ by I_m

$$\frac{I}{I_m} = \frac{1 + I_{sh}}{I_m}$$

$$\frac{I}{I_m} = 1 + \frac{R_m}{R_{sh}}$$

$$\therefore \frac{I}{I_m} = 1 + \frac{R_m}{R_{sh}}$$

$$1 + \frac{R_m}{R_{sh}}$$

is called multiplication factor

Shunt resistance is made of manganin. This has least thermoelectric emf. The change in resistance, due to change in temperature is negligible.

Case (II): Multiplier

A large resistance is connected in series with voltmeter is called multiplier (Fig. 1.9). A large voltage can be measured using a voltmeter of small rating with a multiplier.

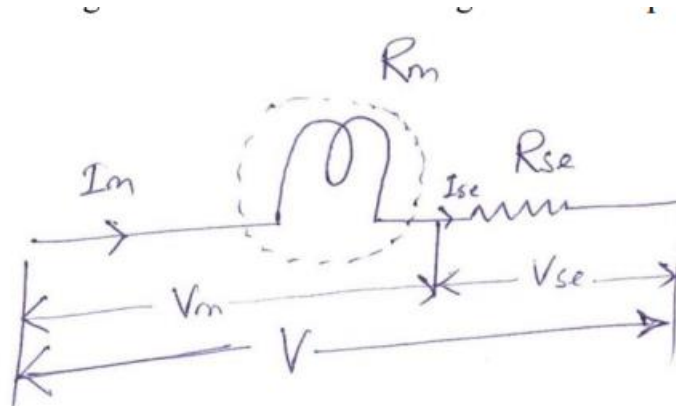

Fig. 1.9

Let R_m = resistance of meter

R_{se} = resistance of multiplier

V_m = Voltage across meter

V_{se} = Voltage across series resistance

V = voltage to be measured

$$\begin{aligned} \frac{I_m}{V_m} &= \frac{I_{se}}{V_{se}} \\ \frac{R_m}{V_m} &= \frac{R_{se}}{V_{se}} \\ \therefore \frac{V_{se}}{V_m} &= \frac{R_{se}}{R_m} \end{aligned}$$

Apply KVL, $V = V_m + V_{se}$ (1.19)

Eqn (1.19) $\div V_m$

$$\begin{aligned} \frac{V}{V_m} &= 1 + \frac{V_{se}}{V_m} \\ &= 1 + \frac{R_{se}}{R_m} \\ \therefore V &= V_m \left(1 + \frac{R_{se}}{R_m} \right) \end{aligned}$$

1.8 Moving Iron (MI) instruments

One of the most accurate instrument used for both AC and DC measurement is moving iron instrument. There are two types of moving iron instrument.

Let the emf induced in the coil be $-e$ volt.

$$e = \frac{d}{dt}(Li) = L \frac{di}{dt} + i \frac{dL}{dt} \quad (1.22)$$

Multiplying by 'idt' in equation (1.22)

$$e \times idt = L \frac{di}{dt} \times idt + i \frac{dL}{dt} \times idt \quad (1.23)$$

$$e \times idt = Lidi + i^2 dL \quad (1.24)$$

Eq (1.24) gives the energy is used in to two forms. Part of energy is stored in the inductance.

Change in energy stored=Final energy-initial energy stored

$$\begin{aligned} &= \frac{1}{2} (L + dL)(i + di)^2 - \frac{1}{2} Li^2 \\ &= \frac{1}{2} \{(L + dL)(i^2 + di^2 + 2idi) - Li^2\} \\ &= \frac{1}{2} \{(L + dL)(i^2 + 2idi) - Li^2\} \\ &= \frac{1}{2} \{Li^2 + 2Lidi + i^2 dL + 2ididL - Li^2\} \\ &= \frac{1}{2} \{2Lidi + i^2 dL\} \\ &= Lidi + \frac{1}{2} i^2 dL \end{aligned}$$

Mechanical work to move the pointer by

$$D\theta = Td \theta$$

By law of conservation of energy,

Electrical energy supplied=Increase in stored energy+ mechanical work done.

Advantages

Input energy = Energy stored + Mechanical energy

$$Lidi + \frac{1}{2} i^2 dL = Lidi + \frac{1}{2} i^2 dL + T_d d\theta$$

$$\frac{1}{2} i^2 dL = T_d d\theta$$

$$\frac{1}{2} \frac{dL}{d\theta} = \frac{T_d}{i^2}$$

At steady state condition $T_d = T_C$

$$\frac{1}{2} i^2 \frac{dL}{d\theta} = K\theta$$

$$\theta = \frac{1}{2K} i^2 \frac{dL}{d\theta}$$

$$\theta \propto i^2$$

When the instruments measure AC, $\theta \propto I_{rms}^2$

Scale of the instrument is non uniform.

- MI can be used in AC and DC
- It is cheap
- Supply is given to a fixed coil, not in moving coil. Simple construction
- Less friction error.

Disadvantages

- It suffers from eddy current and hysteresis error Scale is not uniform
- It consumed more power
- Calibration is different for AC and DC operation

1.8.2 Repulsion type moving iron instrument

Construction:

The repulsion type instrument has a hollow fixed iron attached to it (Fig. 1.12). The moving iron is connected to the spindle. The pointer is also attached to the spindle in supported with jeweled bearing.

Principle of operation:

When the current flows through the coil, a magnetic field is produced by it. So both fixed iron and moving iron are magnetized with the same polarity, since they are kept in the same magnetic field. Similar poles of fixed and moving iron get repelled. Thus the deflecting torque is produced due to magnetic repulsion. Since moving iron is attached to spindle, the spindle will move. So that pointer moves over the calibrated scale. Damping: Air friction damping is used to reduce the oscillation.

Control: Spring control is used.

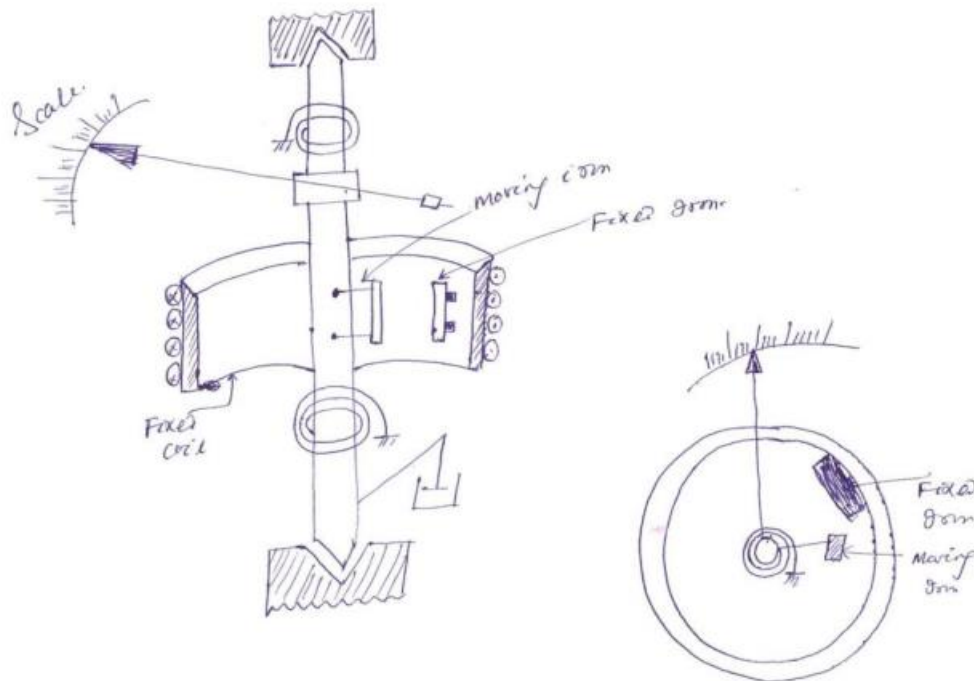

Fig. 1.12

1.9 Dynamometer (or) Electromagnetic moving coil instrument (EMMC)

This instrument can be used for the measurement of voltage, current and power. The difference between the PMMC and dynamometer type instrument is that the permanent magnet is replaced by an electromagnet.

Construction:

A fixed coil is divided into two equal halves. The moving coil is placed between the two halves of the fixed coil. Both the fixed and moving coils are air-cored. So that the hysteresis effect will be zero. The pointer is attached with the spindle. In a non-metallic former the moving coil is wound.

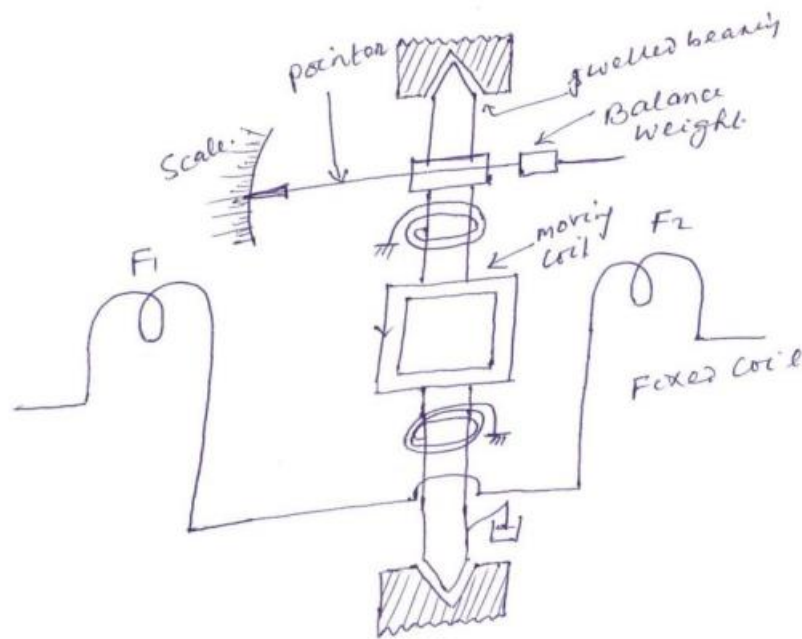

Fig. 1.13

Control: Spring control is used.

Damping: Air friction damping is used.

Principle of operation:

When the current flows through the fixed coil, it produced a magnetic field, whose flux density is proportional to the current through the fixed coil. The moving coil is kept in between the fixed coil. When the current passes through the moving coil, a magnetic field is produced by this coil.

The magnetic poles are produced in such a way that the torque produced on the moving coil deflects the pointer over the calibrated scale. This instrument works on AC and DC. When AC voltage is applied, alternating current flows through the fixed coil and moving coil. When the current in the fixed coil reverses, the current in the moving coil also reverses. Torque remains in the same direction. Since the current i_1 and i_2 reverse simultaneously. This is because the fixed and moving coils are either connected in series or parallel.

Torque developed by EMMC

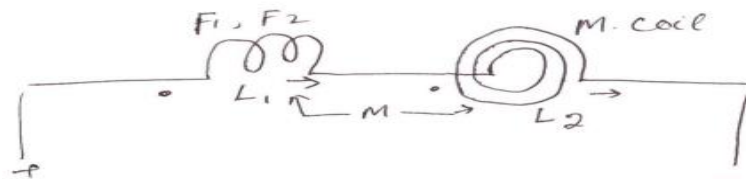

Fig. 1.14

Let, L_1 = Self inductance of fixed coil

L_2 = Self inductance of moving coil

M = mutual inductance between fixed coil and moving

coil i_1 = current through fixed coil

i_2 = current through moving coil

Total inductance of system,

$$L_{total} = L_1 + L_2 + 2M$$

But we know that in case of M.I

$$T_d = \frac{1}{2} i^2 \frac{d(L)}{d\theta} \tag{1.33}$$

$$T_d = i^2 \frac{d(L_1 + L_2 + 2M)}{d\theta} \tag{1.34}$$

The value of L_1 and L_2 are independent of ' θ ' but ' M ' varies with θ

$$T_d = \frac{1}{2} i_1 \times 2 \frac{dM}{d\theta} \tag{1.35}$$

$$T_d = i_1 i_2 \frac{dM}{d\theta} \tag{1.36}$$

If the coils are not connected in series $i_1 = i_2 = i$

$$T_d = i^2 \frac{dM}{d\theta} \tag{1.37}$$

$$T_C = T_d \tag{1.38}$$

$$\therefore \theta = \frac{i^2}{K} \frac{dM}{d\theta} \tag{1.39}$$

$$\theta = \frac{i^2}{K} \frac{dM}{d\theta} \tag{1.40}$$

Hence the deflection of pointer is proportional to the current passing through fixed coil and moving coil.

Digital Voltmeter

Voltmeter is an electrical measuring instrument used to measure the potential difference between two points. The voltage to be measured may be AC or DC. Two types of voltmeters are available for the purpose of voltage measurement i.e. analog and digital.

Analog voltmeters generally contain a dial with a needle moving over it according to the measure and hence displaying the value of the same. With time analog voltmeters are replaced by digital voltmeters due to the same advantages associated with digital systems.

Although digital voltmeters do not fully replace analog voltmeters, still there are many places where analog voltmeters are preferred over digital voltmeters.

Digital voltmeters display the value of AC or DC voltage being measured directly as discrete numerical instead of a pointer deflection on a continuous scale as in analog instruments.

Advantages Associated with Digital Voltmeters

The advantages of digital voltmeters include:

- Readout of DVMS is easy as it eliminates observational errors in measurement committed by operators.
- Error on account of parallax and approximation is entirely eliminated.
- Reading can be taken very fast.
- Output can be fed to memory devices for storage and future computations.
- Versatile and accurate
- Compact and cheap
- Low power requirements
- Portability increased

Working Principle of Digital Voltmeter

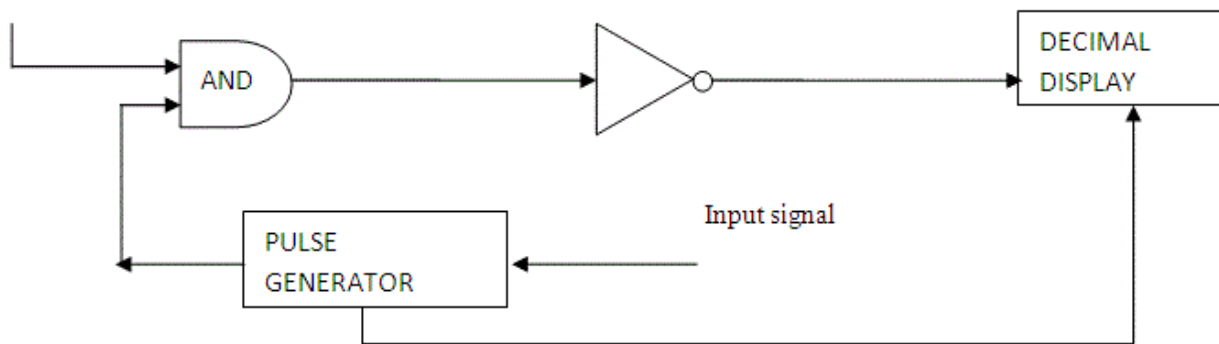

The block diagram of a simple digital voltmeter is shown in the figure.

Explanation of various blocks

Input signal: It is basically the signal i.e. voltage to be measured.

Pulse generator: Actually it is a voltage source. It uses digital, analog or both techniques to generate a rectangular pulse. The width and frequency of the rectangular pulse is controlled by the digital circuitry inside the generator while amplitude and rise and fall time is controlled by analog circuitry.

AND gate: It gives high output only when both the inputs are high. When a train pulse is fed to it along with rectangular pulse, it provides us an output having train pulses with duration as same as the rectangular pulse from the pulse generator.



NOT gate: It inverts the output of AND gate.

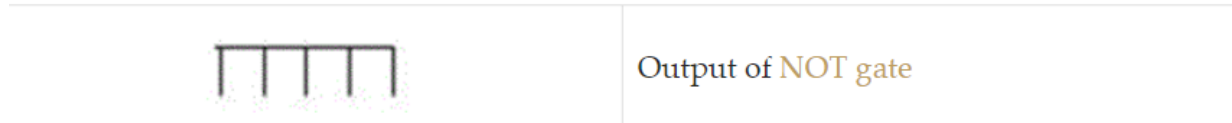

Decimal Display: It counts the numbers of impulses and hence the duration and display the value of voltage on LED or LCD display after calibrating it.

Now we are in situation to understand the working of a digital voltmeter as follows:

- Unknown voltage signal is fed to the pulse generator which generates a pulse whose width is proportional to the input signal.
- Output of pulse generator is fed to one leg of the AND gate.
- The input signal to the other leg of the AND gate is a train of pulses.
- Output of AND gate is positive triggered train of duration same as the width of the pulse generated by the pulse generator.
- This positive triggered train is fed to the inverter which converts it into a negative triggered train.
- Output of the inverter is fed to a counter which counts the number of triggers in the duration which is proportional to the input signal i.e. voltage under measurement.
- Thus, counter can be calibrated to indicate voltage in volts directly.

Digital Frequency Meter

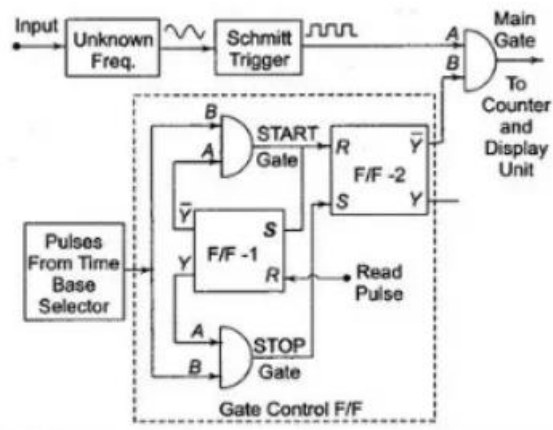

Digital frequency meter is a general purpose instrument that displays the frequency of a periodic electrical signal to an accuracy of three decimal places. It counts the number events occurring within the oscillations during a given interval of time. As the preset period gets completed, the value in the counter display on the screen and the counter reset to zero. Various types of instruments are available which operates at a fixed or variable frequency. But if we operate any frequency meter at different frequencies than the specified range, it could carry out abnormally. For measuring low frequencies, we usually use deflection type meters. The deflection of the pointer on the scale shows the change in frequency. The deflection type instruments are of two types: one is electrically resonant circuits, and other is ratio meter.

Operating Principle of Digital Frequency Meter

A frequency meter has a small device which converts the sinusoidal voltage of the frequency into a train of unidirectional pulses. The frequency of input signal is the displayed count, averaged over a suitable counting interval out of 0.1, 1.0, or 10 seconds. These three intervals repeat themselves sequentially. As the ring counting units reset, these pulses pass through the time-base-gate and then entered into the main gate, which opens for a certain interval. The time base gate prevents a divider pulse from opening the main gate during the display time interval. The main gate acts as a switch when the gate is open; pulses are allowed to pass. When the gate is closed, pulses are not allowed to pass that means the flow of pulses get obstructed.

The functioning of the gate is operated by the main-gate flip-flop. An electronic counter at the gate output that counts the number of pulses passed through the gate while it was open. As the main gate flip-flop receives next divider pulse, the counting interval ends, and divider pulses are locked out. The resultant value displayed on a display screen which has the ring counting units of scale-of-ten circuits and each unit couples to a numeric indicator, which provides the digital display. As the reset pulse generator is triggered, ring counters get reset automatically, and the same procedure starts again.

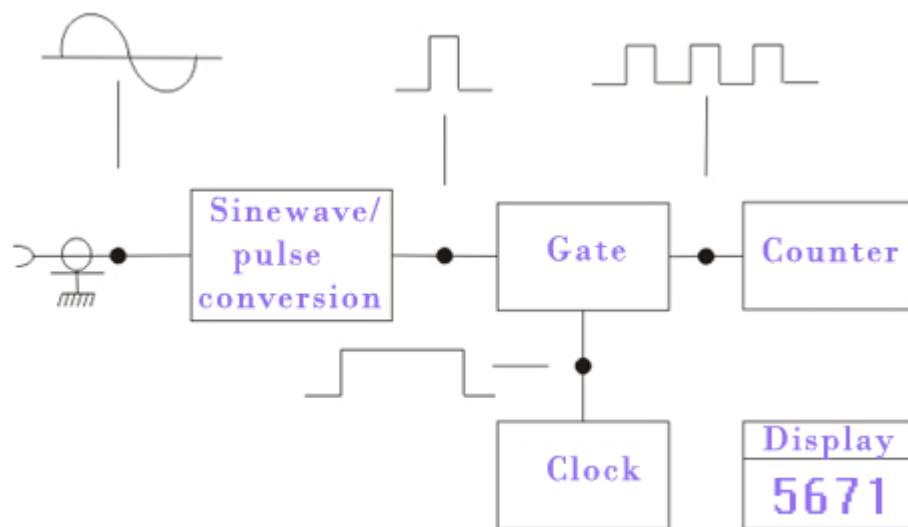

The range of modern digital frequency meter is between the range from 10^4 to 10^9 hertz. The possibility of relative measurement error ranges between from 10^{-9} to 10^{-11} hertz and a sensitivity of 10^{-2} volt.

Use of Digital Frequency Meter

- For testing radio equipment
- Measuring the temperature, pressure, and other physical values.
- Measuring vibration, strain
- Measuring transducers

Digital multimeter

A digital multimeter is a test tool used to measure two or more electrical values—principally voltage (volts), current (amps) and resistance (ohms). It is a standard diagnostic tool for technicians in the electrical/electronic industries.

Digital multimeters long ago replaced needle-based analog meters due to their ability to measure with greater accuracy, reliability and increased impedance. Fluke introduced its first digital multimeter in 1977.

Digital multimeters combine the testing capabilities of single-task meters—the voltmeter (for measuring volts), ammeter (amps) and ohmmeter (ohms). Often, they include several additional specialized features or advanced options. Technicians with specific needs, therefore, can seek out a model targeted to meet their needs.

The face of a multimeter typically includes four components:

- Display: Where measurement readouts can be viewed.
- Buttons: For selecting various functions; the options vary by model.
- Dial (or rotary switch): For selecting primary measurement values (volts, amps, ohms).
- Input jacks: Where test leads are inserted.

Test leads are flexible, insulated wires (red for positive, black for negative) that plug into the DMM. They serve as the conductor from the item being tested to the multimeter. The probe tips on each lead are used for testing circuits.

The terms counts and digits are used to describe a digital multimeter's resolution—how fine a measurement a meter can make. By knowing a multimeter's resolution, a technician can determine if it is possible to see a small change in a measured signal.

Example: If a multimeter offers a resolution of 1 mV on the 4 V range, it is possible to see a change of 1 mV (1/1000th of a volt) while reading 1V.

Digital multimeters are typically grouped by their number of counts (up to 20,000) they display.

Broadly speaking, multimeters fall into one of a handful of categories:

- General purpose (aka Testers)
- Standard
- Advanced
- Compact
- Wireless

Digital Tachometer

A Tachometer is a sophisticated name for a relatively commonplace device. This article focuses attention on digital tachometers, what they are, how they work, and provides common examples of their use. A tachometer measures the rotational speed of a disk or shaft, such as a motor, and expresses results in revolutions per minute (RPM).

You probably encounter tachometers every day, such as in a vehicle with an analogue tachometer that displays the engine's RPM (often located next to a speedometer).

Digital tachometers display readings on an easy-to-read LCD screen. One of the main benefits a digital tachometer has over its analogue counterparts is the ability to provide more precise and steady readings. Other significant advantages digital tachometers can have over analogue tachometers include; the ability to change units of measurement, recall last readings, and view minimum, maximum, and average measurements.

Types of Digital Tachometers

You will find two main categories of digital tachometers based on the device's measurement technique, contact and non-contact.

1. Non-Contact

Non-contact tachometers do not need to make any physical contact with a rotating shaft to obtain a measurement. These meters often employ a reflector on the shaft to be measured, and an infrared laser pointed at the rotating shaft. Each time a shaft rotates and the laser meets the reflector, light bounces back to a sensor in the tachometer. The tachometer counts each time this occurs. The meter will calculate the number of times the sensor is triggered over a given time and processes the result in revolutions per minute.

2. Contact

Contact tachometers have a freely spinning wheel that is brought into direct contact with the rotating shaft to be measured. The wheel spins freely, creating pulses that are interpreted by the tachometer and converted into RPM. Many contact tachometers also calculate and display linear speed and distance.

Uses for Digital Tachometers

Digital tachometers have an extensive range of industrial and commercial applications including;

- Modes of transport such as car, planes, trucks, tractors, trains, trams and light rail
- Industrial and farm machinery
- Manufacturing facilities, and
- Research and education.

UNIT-II: MEASUREMENT OF POWER, POWER FACTOR AND ENERGY

Single And Three Phase Wattmeters And Energy Meters

Single Phase Induction Type Meters

The construction and principle of operation of Single Phase Energy Meters is explained below

Construction of Induction Type Energy Meters

There are four main parts of the operating mechanism

- [1]. Driving system
- [2]. Moving system
- [3]. Braking system
- [4]. Registering system

Driving system:

The driving system of the meter consists of two electro-magnets.

The core of these electromagnets is made up of silicon steel laminations. The coil of one of the electromagnets is excited by the load current. This coil is called the current coil.

The coil of second electromagnet is connected across the supply and, therefore, carries a current proportional to the supply voltage. This coil is called the pressure coil.

Consequently the two electromagnets are known as series and shunt magnets respectively.

Copper shading bands are provided on the central limb. The position of these bands is adjustable.

The function of these bands is to bring the flux produced by the shunt magnet exactly in quadrature with the applied voltage.

Moving System:

This consists of an aluminum disc mounted on a light alloy shaft.

This disc is positioned in the air gap between series and shunt magnets. The upper bearing of the rotor (moving system) is a steel pin located in a hole in the bearing cap fixed to the top of the shaft.

The rotor runs on a hardened steel pivot, screwed to the foot of the shaft. The pivot is supported by a jewel bearing.

A pinion engages the shaft with the counting or registering mechanism.

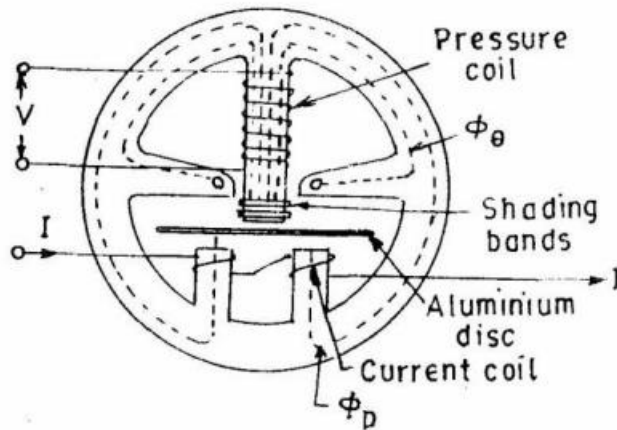

(Fig) single phase energy meter

Braking System

A permanent magnet positioned near the edge of the aluminium disc forms the braking system. The aluminium disc moves in the field of this magnet and thus provides a braking torque.

The position of the permanent magnet is adjustable, and therefore braking torque can be adjusted by shifting the permanent magnet to different radial positions as explained earlier.

Registering (counting) Mechanism

The function of a registering or counting mechanism is to record continuously a number which is proportional to the revolutions made by the moving system. By a suitable system, a train of reduction gears the pinion on the rotor shaft drives a series of five or six pointers.

These rotate on round dials which are marked with ten equal divisions.

The pointer type of register is shown in Fig. Cyclo-meter register as shown in Fig can also be used.

Errors in Single Phase Energy Meters

The errors caused by the driving system are

1. Incorrect magnitude of fluxes
2. Incorrect phase angles.
3. Lack of Symmetry in magnetic circuit.

The errors caused by the braking system are

1. changes in strength of brake magnet
2. changes in disc resistance
3. abnormal friction
4. self braking effect

Double Element Wattmeter (or) Two Wattmeter Method

A three-phase two-watt meter measures the current and voltage from any of the 2 supply lines of 3 phase corresponding to the 3rd supply line of 3 phase. The 3 phase 2 wattmeter is said to be at a balanced load condition if the current in every phase lag at an angle " ϕ " with phase voltage.

Construction of Two Wattmeter Method

The 3-phase power of a 3-phase circuit can be measured using 3 ways they are,

3 Wattmeter Method

2 Wattmeter Method

1 Wattmeter Method.

The main concept of 2 Wattmeter with 3 phase voltage is to balance the 3 phase load by satisfying the condition of current lagging at an angle ' ϕ ' with the voltage phase. The schematic diagram of 3 phase 2 wattmeter is shown below

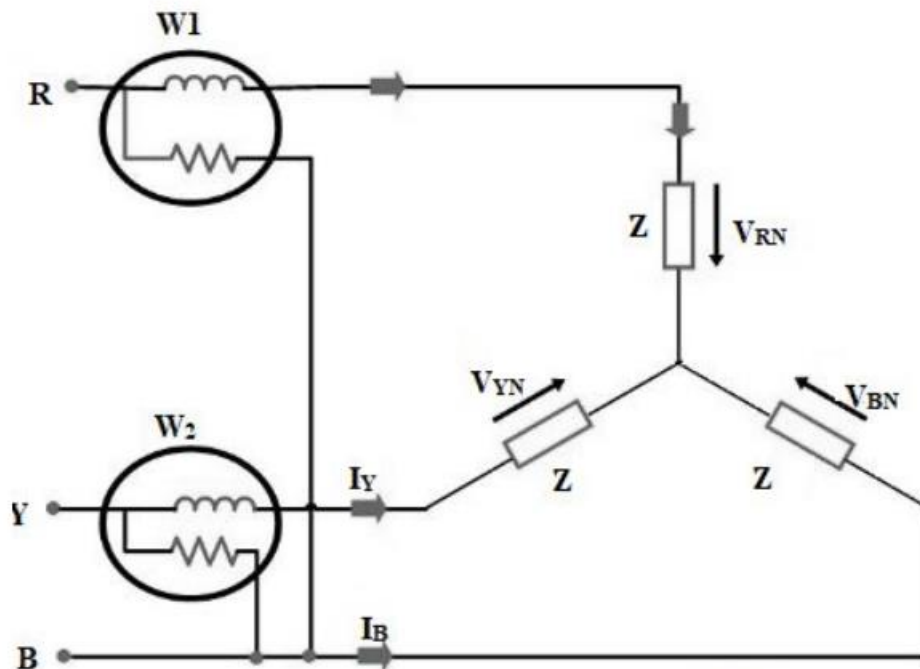

It consists of 2 wattmeters like W1 and W2, where each wattmeter has a current coil 'CC' and a pressure coil 'PC'. Here, one end of wattmeter 'W1' is connected to 'R' terminal whereas one end of wattmeter 'W2' is connected to 'Y' terminal. The circuit also consists of 3 inductors 'Z' which are constructed in a star topology. The 2 ends of inductors are connected to 2 terminals of a wattmeter whereas the third terminal of the inductor is connected to B.

Derivation of Two Wattmeter Method

Two Wattmeter is used to determine two main parameters they are,

- Power factor
- Reactive power.

Consider the load used as an inductive load which is represented by following the phasor diagram as shown below.

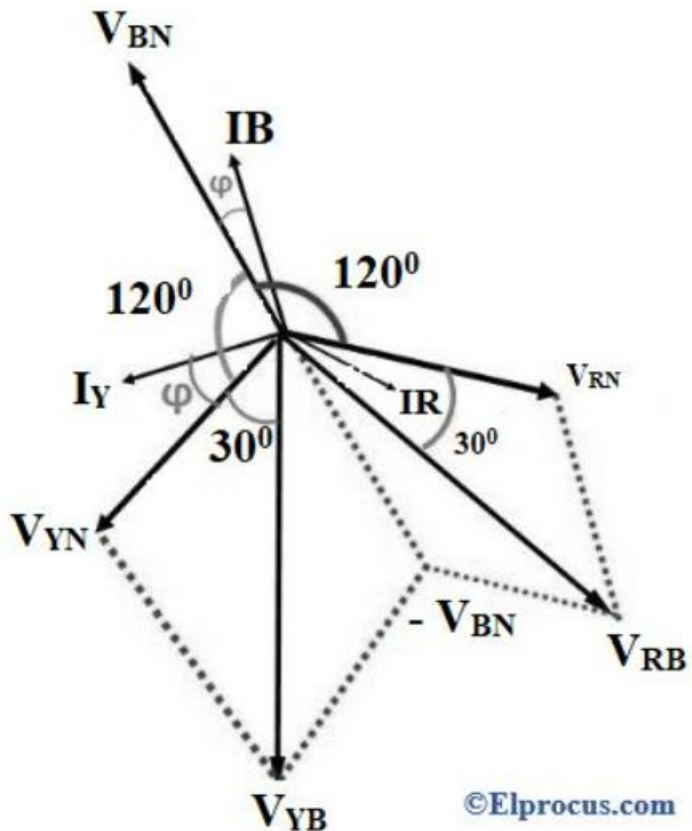

Phasor Diagram

The voltages V_{RN} , V_{YN} , and V_{BN} are electrically 120° in phase with one other, we can observe that the current phase lags at the “ ϕ ” angle with voltage phase.

The current in wattmeter W1 is represented as

where I_R is current

The potential difference across the wattmeter W1 coil is given as

$$W_1 = \sim V_{RB} = [\sim V_{RN} - \sim V_{BN}] \dots\dots\dots (2)$$

Where V_{RN} and V_{BN} are voltages

The phase difference between the voltage ‘ V_{YB} ’ and current ‘ I_Y ’ is given as $(300 + \phi)$

Hence the power measured by wattmeter is given as

$$W_2 = V_{YB} I_Y \cos (300 + \phi) \dots\dots\dots (3)$$

At balanced load condition,

$$W1 = VL IL \cos(300 - \varphi) \text{ and } \dots\dots\dots (6)$$

$$W2 = VL IL \cos(300 + \varphi) \dots\dots\dots (7)$$

Total Power Derivation

The total wattmeter reading is given as

$$W1 + W2 = VL IL \cos(300 - \varphi) + VL IL \cos(300 + \varphi) \dots\dots\dots (8)$$

$$= VL IL [\cos(300 - \varphi) + \cos(300 + \varphi)]$$

$$= VL IL [\cos 300 \cos \varphi + \sin 300 \sin \varphi + \cos 300 \cos \varphi - \sin 300 \sin \varphi]$$

$$= VL IL [2 \cos 300 \cos \varphi]$$

$$= VL IL [(2 \sqrt{3} / 2) \cos 300 \cos \varphi]$$

$$= \sqrt{3} [VL IL \cos \varphi] \dots\dots\dots (9)$$

$$W1 + W2 = P \dots\dots (10)$$

Where 'P' is the total observed power in a 3-phase balanced load condition.

Power Factor Derivation

Definition: It is the ratio between actual power observed by the load to apparent power flowing in the circuit.

The power factor of three phase balanced load condition can be determined and derived from wattmeter readings as follows

From equation 9

$$W1 + W2 = \sqrt{3} VL IL \cos \varphi$$

$$\text{Now } W1 - W2 = VL IL [\cos(300 - \varphi) - \cos(300 + \varphi)]$$

$$= VL IL [\cos 300 \cos \varphi + \sin 300 \sin \varphi - \cos 300 \cos \varphi + \sin 300 \sin \varphi]$$

$$= 2 VL IL \sin 300 \sin \varphi$$

$$W1 - W2 = VL IL \sin \varphi \dots\dots\dots (11)$$

Dividing equations 11 and 9

$$[W1 - W2 \setminus W1 + W2] = VL IL \sin \varphi / \sqrt{3} VL IL \cos \varphi$$

$$\text{Tan } \varphi = \sqrt{3} [W1 - W2 \setminus W1 + W2]$$

The power factor of the load is given as

$$\cos \varphi = \cos \tan^{-1} [\sqrt{3} [W1 - W2 \setminus W1 + W2]] \dots\dots\dots(12)$$

Reactive Power Derivation

Definition: It is the ratio between complex power corresponding to storage and revival of energy rather than consumption.

To obtain reactive power, we multiply equation 11 with

$$\sqrt{3} [W1 - W2] = \sqrt{3} [VL IL \sin \phi] = Pr$$

$$Pr = \sqrt{3} [W1 - W2] \dots\dots\dots (13)$$

Where Pr is the reactive power obtained from 2 wattmeters.

Two Wattmeter Method Table

The two wattmeter method observations can be noted practically by following the table.

S.NO	Voltage VL (volts)	Current IL (amp)	Power W1 (watts)	Power W2 (watts)	Total Power P = W1 + W2	Power Factor = cos ϕ
1						
2						
3						

Precaution

The following are the precautions to be followed

- Connections are to be made tightly
- Avoid the parallel axial error.

Advantages of Two Wattmeter

The following are the advantages

- Both balanced and unbalanced load can be balanced using this method
- In a star connected load, it is optional to connect neutral point and wattmeter
- In a delta, connected load connections need not be opened to connect wattmeter
- 3 phase power can be measured using two wattmeter's
- Both power and power factor is determined on a balanced load condition.

Disadvantages of Two Wattmeter

The following are the disadvantages

- Not suitable for 3 phase, 4 wire system
- Primary windings W1 and secondary windings W2 must be identified correctly to prevent incorrect results.

Applications of Two Wattmeter

The following are the applications

- Wattmeters are used to measure the power consumption of any electrical appliances and verify their power ratings.

Three-Wattmeter Method of Three-Phase Power Measurement

Three Wattmeter method is employed to measure power in a 3 phase, 4 wire system. However, this method can also be employed in a 3 phase, 3 wire delta connected load, where power consumed by each load is required to be determined separately.

The connections for star connected loads for measuring power by three wattmeter method is shown below:

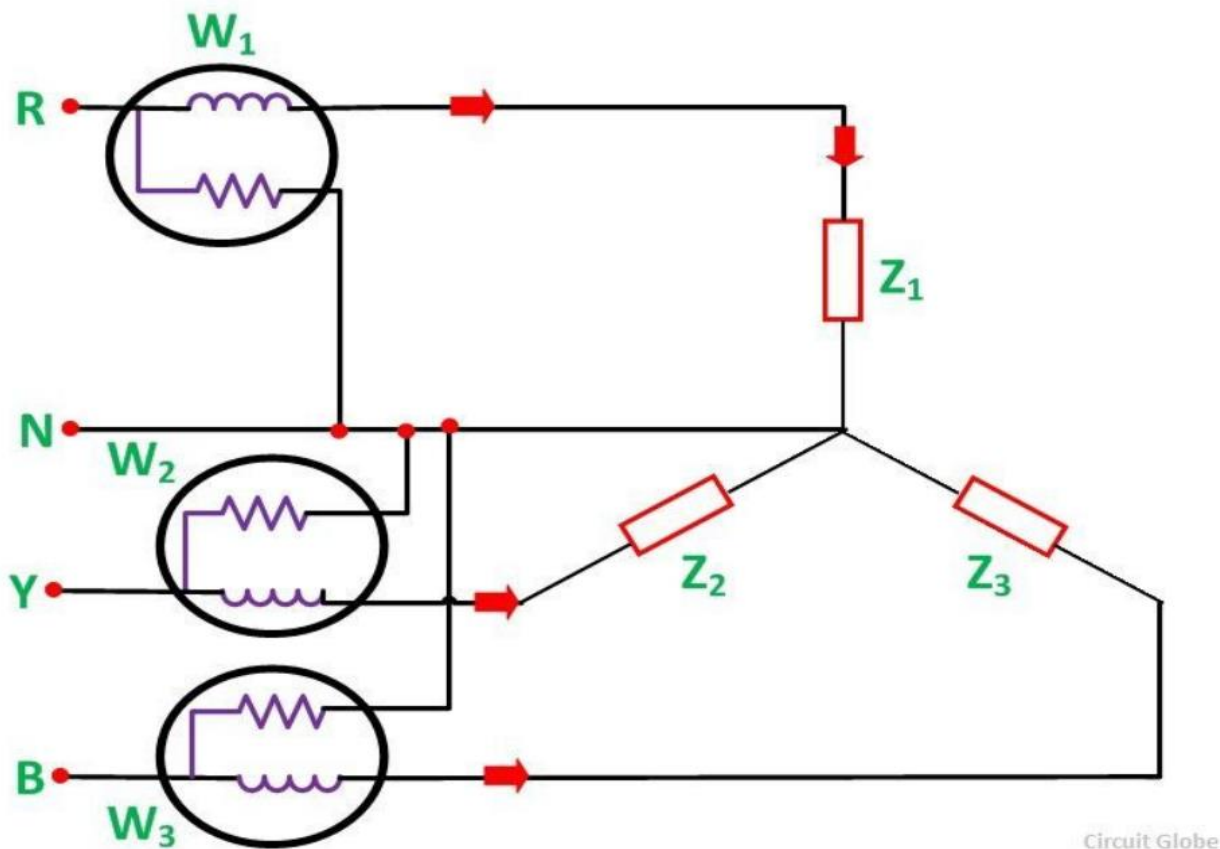

The pressure coil of all the three wattmeters namely W₁, W₂ and W₃ are connected to a common terminal known as the neutral point. The product of the phase current and line voltage represents phase power and is recorded by an individual wattmeter.

The total power in a three wattmeter method of power measurement is given by the algebraic sum of the readings of three wattmeters. i.e.

$$\text{Total power } P = W_1 + W_2 + W_3$$

Where,

$$W1 = V1I1$$

$$W2 = V2I2$$

$$W3 = V3I3$$

Except for 3 phase, 4 wire unbalanced load, 3 phase power can be measured by using only Two Wattmeter Method.

Power Factor Meter

Definition: The power factor meter measures the power factor of a transmission system. The power factor is the cosine of the angle between the voltage and current. The power factor meter determines the types of load using on the line, and it also calculates the losses occur on it.

The power factor of the transmission line is measured by dividing the product of voltage and current with the power. And the value of voltage current and power is easily determined by the voltmeter, ammeter and wattmeter respectively. This method gives high accuracy, but it takes time.

The power factor of the transmission line is continuously changed with time. Hence it is essential to take the quick reading. The power factor meter takes a direct reading, but it is less accurate. The reading obtained from the power factor meter is sufficient for many purposes to expect precision testing.

The power factor meter has the moving system called pointer which is in equilibrium with the two opposing forces. Thus, the pointer of the power factor meter remains at the same position which is occupied by it at the time of disconnection.

Types of Power Factor Meter

The power factor meter is of two types. They are

1. Electrodynamicometer
 - Single Phase Electrodynamicometer
 - Three Phases Electrodynamicometer
2. Moving Iron Type Meter
 - Rotating Iron Magnetic Field
 - Number of Alternating Field

The different types of power factor meter are explained below in details.

Single Phase Electrodynamicometer Power Factor Meter

The construction of the single phase electrodynamicometer is shown in the figure below. The meter has fixed coil which acts as a current coil. This coil is split into two parts and carry the current under test. The magnetic field of the coil is directly proportional to the current flow through the coil.

The meter has two identical pressure coils A and B. Both the coils are pivoted on the spindle. The pressure coil A has no inductive resistance connected in series with the circuit, and the coil B has highly inductive coil connected in series with the circuit.

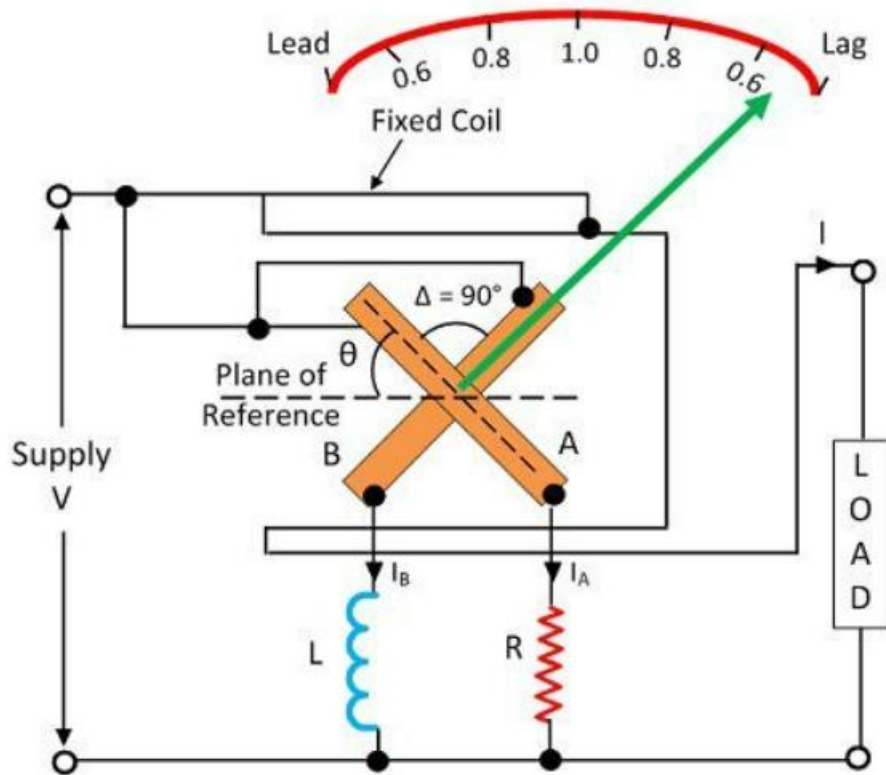

Single Phase Electrodynamicometer
Type Power Factor Meter

Circuit Globe

The current in the coil A is in phase with the circuit while the current in the coil B lag by the voltage nearly equal to 90° . The connection of the moving coil is made through silver or gold ligaments which minimize the controlling torque of the moving system.

The meter has two deflecting torque one acting on the coil A, and the other is on coil B. The windings are so arranged that they are opposite in directions. The pointer is in equilibrium when the torques are equal.

Deflecting torque acting on the coil A is given as

$$T_A = KVIM \cos \phi \sin \theta$$

θ – angular deflection from the plane of reference.

M_{max} – maximum value of mutual inductance between the coils.

The deflecting torque acting on coil B is expressed as

$$I_B = KVIM_{max} \cos(90^\circ - \phi) \sin(90^\circ + \phi)$$

$$I_B = KVIM_{max} \cos \phi \sin \theta$$

The deflecting torque is acting on the clockwise direction.

The value of maximum mutual inductance is same between both the deflecting equations.

$$T_A = T_B$$

$$KVIM \cos \phi \sin \theta = KVIM_{max} \cos \phi \sin \theta$$

This torque acts on anti-clockwise direction. The above equation shows that the deflecting torque is equal to the phase angle of the circuit.

Three Phase Electrodynamic Power Factor Meter

The construction of the three phase meter is shown in the figure below. The electrodynamicometer is only useful for the balanced load. The moving coil is placed at an angle of 120° . They are connected across different phases of the supply circuit. Both the coil has a series resistance.

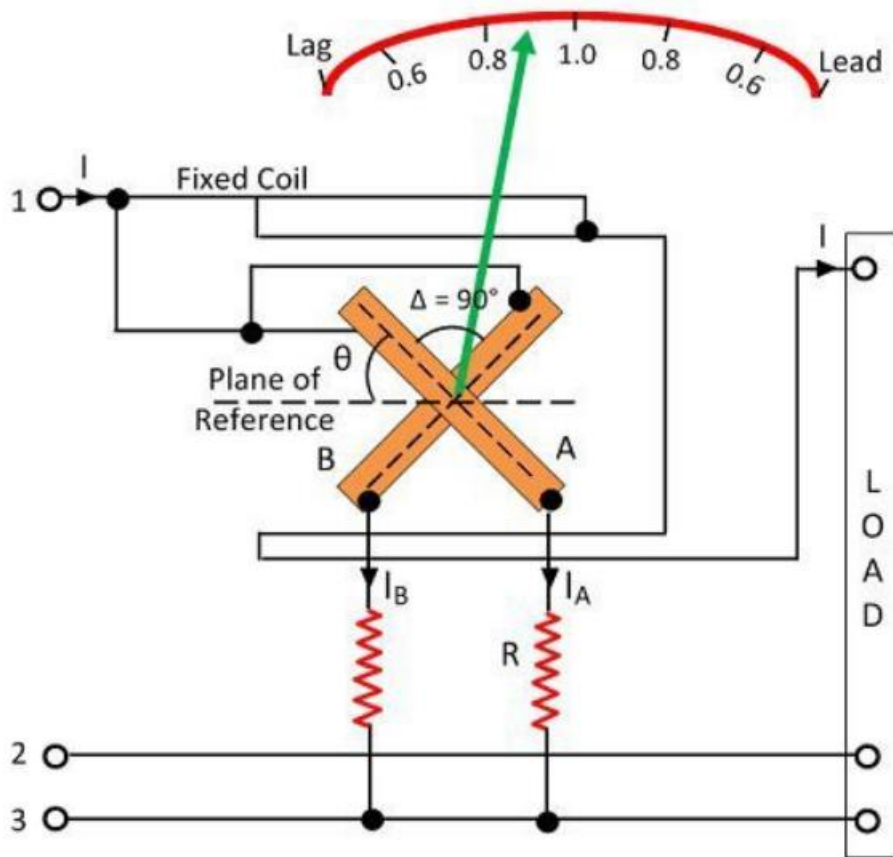

Three Phase Dynamo Type Factor Meter

Circuit Globe

The voltage across the coil A is V_{12} and the current across it I_{A1} . The circuit of the coil is resistive, and hence the current and voltage are in phase with each other. Similarly, the voltage V_{13} and the current I_{B1} is in phase with each other.

The phasor diagram of the three phase electrodynamic meter is shown in the figure below.

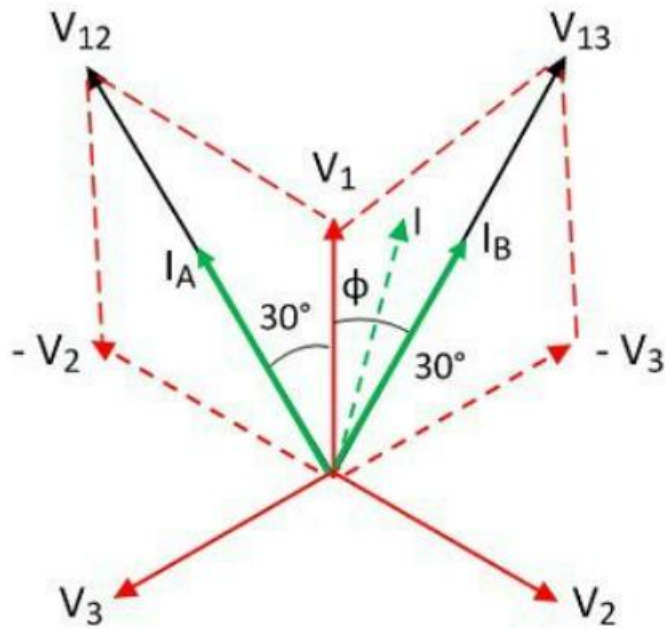

Phasor Diagram of Three Phase
Electrodynamometer Type Power Factor Meter

Let Φ – phase angle of the circuit.

θ – angular deflection from the plane of reference.

Torque acting on coil A is

$$T_A = KVI_{12}M_{max} \cos(30^\circ + \phi) \sin(60^\circ + \phi)$$

$$T_A = \sqrt{3}KVI_{12}M_{max} \cos(30^\circ + \phi) \sin(60^\circ + \phi)$$

Torque acting on coil B is

$$T_B = KVI_{12}M_{max} \cos(30^\circ - \phi) \sin(120^\circ + \phi)$$

$$T_B = KVI_{12}M_{max} \cos(30^\circ - \phi) \sin(120^\circ + \phi)$$

The torque T_A and T_B are acting on the opposite directions.

$$\cos(30^\circ - \phi) \sin(120^\circ + \phi) = \cos(30^\circ - \phi) \sin(120^\circ + \phi)$$

Thus the angular deflection of the coil is directly proportional to the phase angle of the circuit.

Moving Iron Power Factor Meter

The moving iron instrument is divided into two categories. They are the rotating magnetic field to some alternating fields.

A. Rotating Field Power factor Meter – The following are the essential feature of the rotating magnetic field. The power factor meter has three fixed coils, and their axes are 120° displaced from each other. The axes are intersecting each other. The coils are connected to the three phase supply with the help of the current transformer.

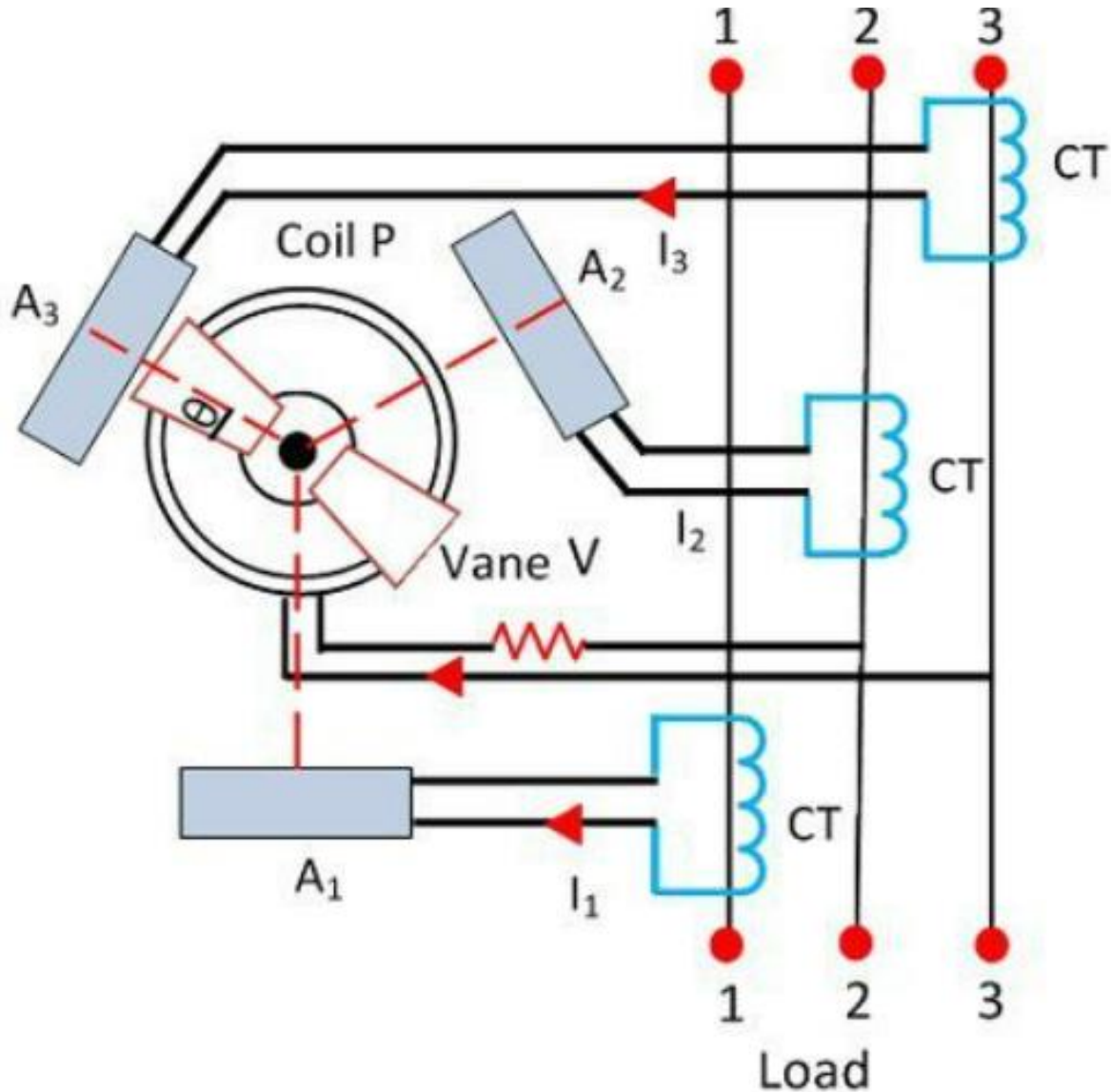

Rotating Field Moving iron Power Factor Meter

The P is the fixed coil connected in series with the high resistance circuit across the phases 2 and 3. There is an iron cylinder across coil P. The two iron vanes are fixed to the cylinder. The spindles also carry damping vanes and pointer.

The phasor diagram of the power factor meter is shown in the figure.

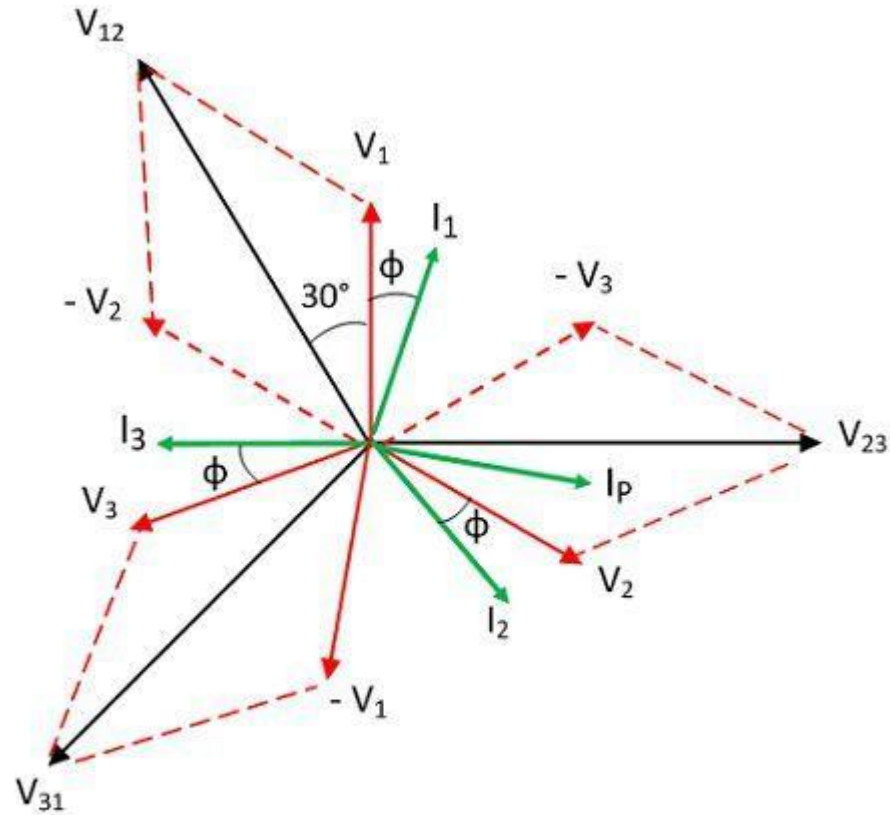

Phasor Diagram for Moving Iron Type Power Factor Meter

Circuit Globe

The total torque of the meter is zero for steady state deflection.

$$[\cos(90^\circ - \phi)\sin(90^\circ + \phi) + \cos(330^\circ - \phi)\sin(210^\circ + \phi) + \cos(210^\circ - \phi)\sin(330^\circ + \phi)] = 0$$

The coil P and the iron cylinders generate the alternating flux which interacts with the flux of the fixed coils. The interaction of the coil generates the moving system which determined the phase angle of the current. The vanes of the power factor meter are magnetized by the current of the moving coil which is in phase with the system line voltage.

Advantages of Moving Iron power Power Factor

1. The meter requires large working force as compared to the electrodynamic meter type meter.
2. The coils of the moving iron instruments are fixed permanently.
3. The range of the scale extends up to 360°.
4. The construction of the meter is robust and simple.
5. The moving iron instrument is cheap as compared to electrodynamic meter.

Disadvantages of moving iron instrument

1. The loss occurs in the iron part of the meter. The losses depend on the load and the frequency of the meter.
2. The meter has low accuracy.
3. The calibration of the meter is affected because of the variation in supply frequencies, voltage and waveforms etc.

The power factor meter is used for measuring the power factor of the balanced load.

Energy Meter

Definition: The meter which is used for measuring the energy utilises by the electric load is known as the energy meter. The energy is the total power consumed and utilised by the load at a particular interval of time. It is used in domestic and industrial AC circuit for measuring the power consumption. The meter is less expensive and accurate.

Construction of Energy Meter

The construction of the single phase energy meter is shown in the figure below.

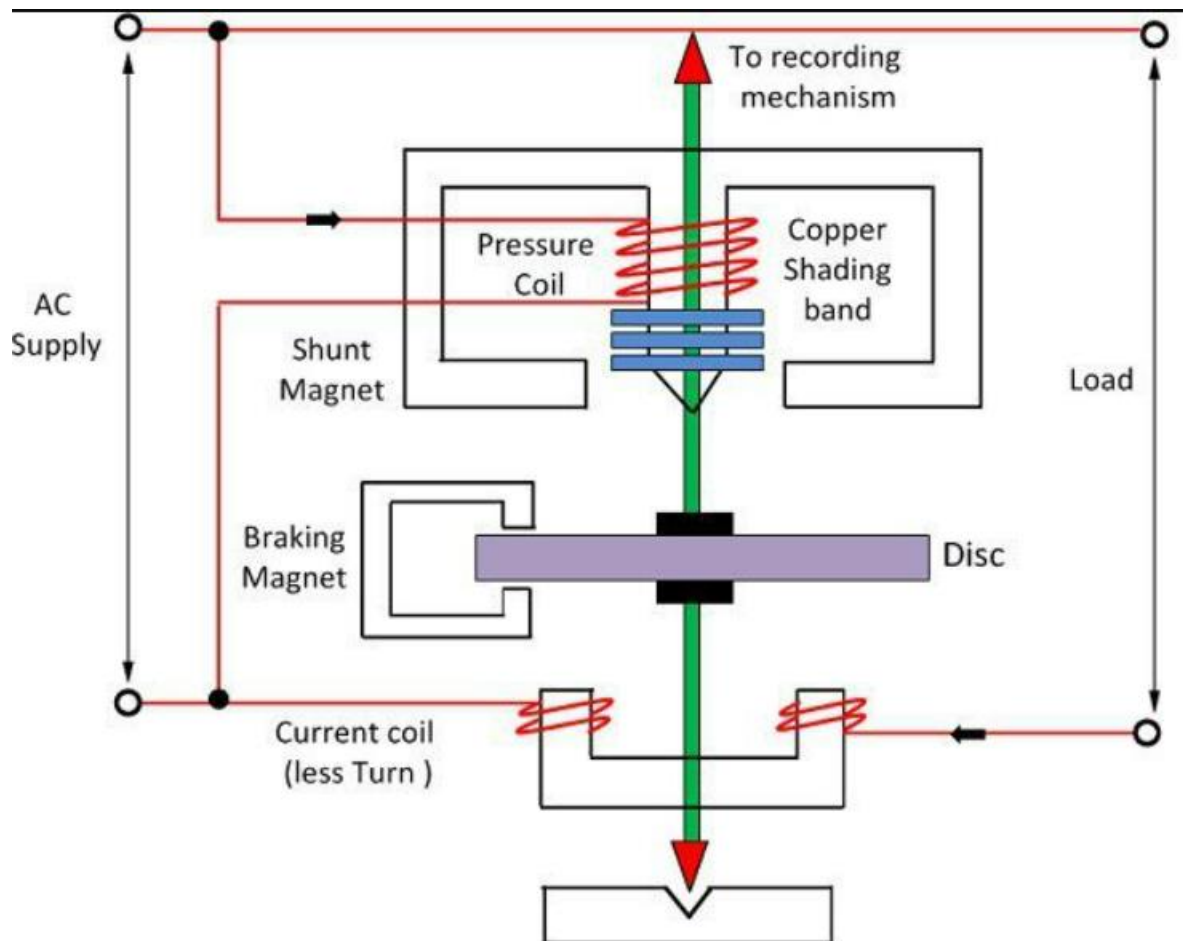

Induction Type Energy Meter

The energy meter has four main parts. They are the

3. Driving System
4. Moving System
5. Braking System
6. Registering System

The detail explanation of their parts is written below.

1. Driving System – The electromagnet is the main component of the driving system. It is the temporary magnet which is excited by the current flow through their coil. The core of the electromagnet is made up of silicon steel lamination. The driving system has two electromagnets. The upper one is called the shunt electromagnet, and the lower one is called series electromagnet.

The series electromagnet is excited by the load current flow through the current coil. The coil of the shunt electromagnet is directly connected with the supply and hence carry the current proportional to the shunt voltage. This coil is called the pressure coil.

The centre limb of the magnet has the copper band. These bands are adjustable. The main function of the copper band is to align the flux produced by the shunt magnet in such a way that it is exactly perpendicular to the supplied voltage.

2. Moving System – The moving system is the aluminium disc mounted on the shaft of the alloy. The disc is placed in the air gap of the two electromagnets. The eddy current is induced in the disc because of the change of the magnetic field. This eddy current is cut by the magnetic flux. The interaction of the flux and the disc induces the deflecting torque.

When the devices consume power, the aluminium disc starts rotating, and after some number of rotations, the disc displays the unit used by the load. The number of rotations of the disc is counted at particular interval of time. The disc measured the power consumption in kilowatt hours.

3. Braking system – The permanent magnet is used for reducing the rotation of the aluminium disc. The aluminium disc induces the eddy current because of their rotation. The eddy current cut the magnetic flux of the permanent magnet and hence produces the braking torque.

This braking torque opposes the movement of the disc, thus reduces their speed. The permanent magnet is adjustable due to which the braking torque is also adjusted by shifting the magnet to the other radial position.

4. Registration (Counting Mechanism) – The main function of the registration or counting mechanism is to record the number of rotations of the aluminium disc. Their rotation is directly proportional to the energy consumed by the loads in the kilowatt hour.

The rotation of the disc is transmitted to the pointers of the different dial for recording the different readings. The reading in kWh is obtained by multiply the number of rotations of the disc with the meter constant. The figure of the dial is shown below.

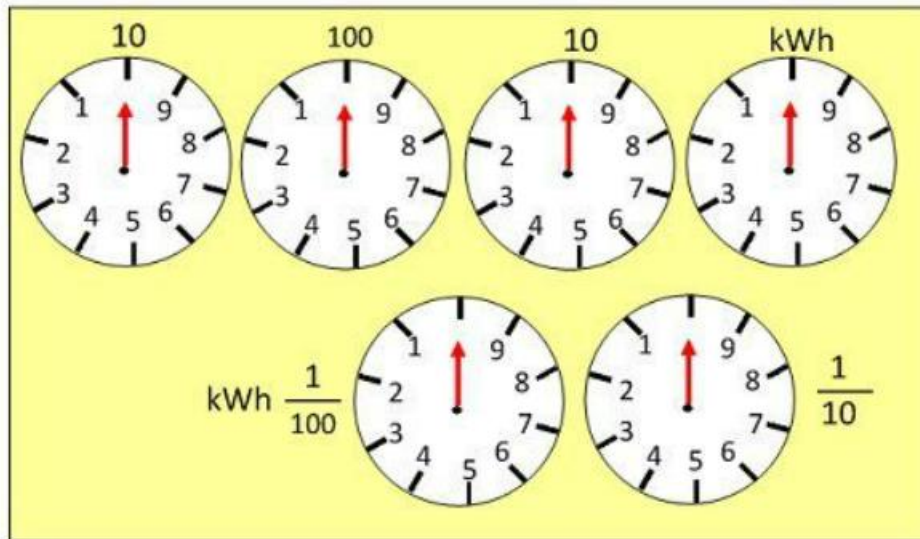

Pointer Type of Register

Circuit Globe

Working of the Energy Meter

The energy meter has the aluminium disc whose rotation determines the power consumption of the load. The disc is placed between the air gap of the series and shunt electromagnet. The shunt magnet has the pressure coil, and the series magnet has the current coil.

The pressure coil creates the magnetic field because of the supply voltage, and the current coil produces it because of the current.

The field induced by the voltage coil is lagging by 90° on the magnetic field of the current coil because of which eddy current induced in the disc. The interaction of the eddy current and the magnetic field causes torque, which exerts a force on the disc. Thus, the disc starts rotating.

The force on the disc is proportional to the current and voltage of the coil. The permanent magnet controls their rotation. The permanent magnet opposes the movement of the disc and equalises it on the power consumption. The cyclometer counts the rotation of the disc.

Three Phase Energy Meter

In order to measure the energy consumption of a three-phase circuit three-phase energy meters are used. The three-phase energy meter can be built by two single-phase energy meters, by adding the readings of two meters gives total energy consumption in the 3-phase circuit.

Construction of Three Phase Energy Meter :

The construction of a three-phase induction type energy meter appears as an assembly of two single-phase induction type energy meters in one case, having a common spindle and registering mechanism. The schematic diagram of the meter is shown in the below figure.

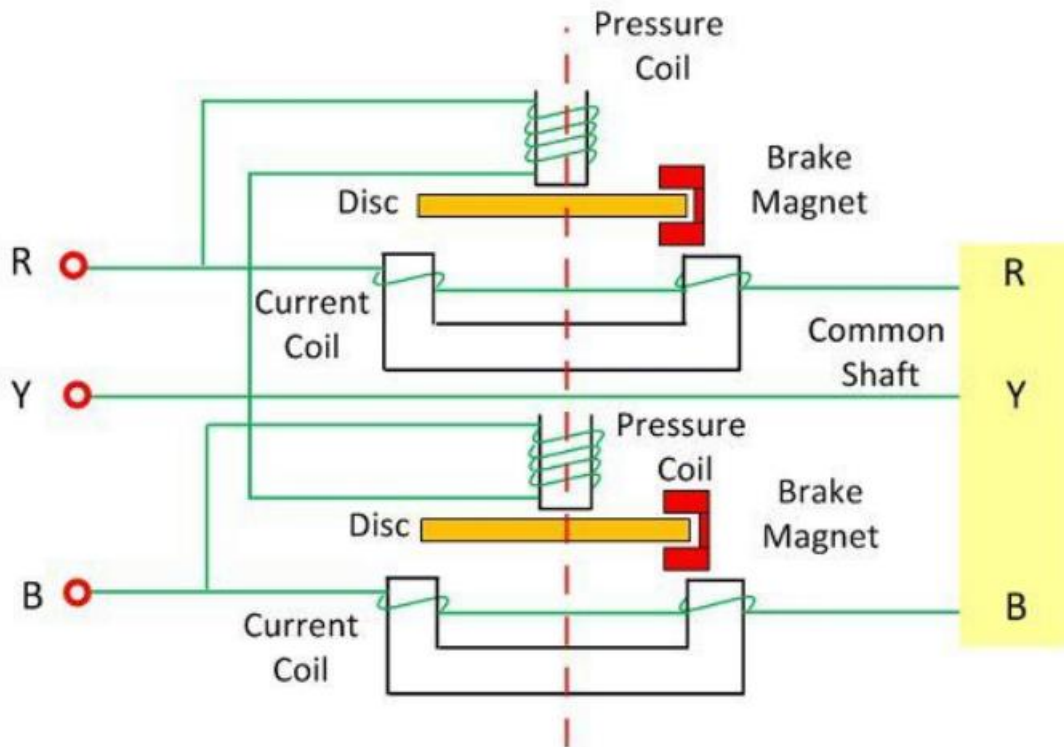

Three Phase Energy Meter

Circuit Globe

For three phase meter, the driving torque of both the elements is equal. This can be done by adjusting the torque. The torque is adjusted by connecting the current coils of both the elements in the series and their potential coils in parallel. The full load current is passed through the coil due to which the two opposite torque is set up in the coil.

The strength of both the torques are equal, and hence they do not allow the disc to rotate. If the torque becomes unequal and the disc rotates then the magnetic shunt is adjusted. The balance torque is obtained before testing the meter. The position of the compensator and the braking magnet are separately adjusted to each of the element for obtaining the balance torque.

Working of Three Phase Energy Meter :

The principle of working of a 3-phase energy meter is similar to the single-phase energy meter. When the load is connected to the meter both the pressure coil and the current coil of the two elements mounted on the shunt and series magnet produces magnetic flux. This flux when links with the discs cause an eddy current to flow in it.

Interaction of eddy currents with the flux imposed by the two coils causes the production of torque on discs. Since two discs are attached to one spindle, the torque exerted on the two discs added mechanically. Hence, rotation of the shaft gives the 3-phase energy consumed.

Errors in Energy Meter & Adjustments for Compensation of Errors

The various types of errors in an energy meter are caused by the driving system and braking system.

Errors Caused by Driving System :

- Errors due to the incorrect magnitude of fluxes. These are mainly due to variations in supply voltage or load current. The flux produced by the shunt magnet varies with variations in supply frequency or coil resistance.
- Incorrect phase angles between various parameters like induced emf, current, and flux. These are mainly due to variation in supply frequency, incorrect lag adjustments, change in resistance of coils with temperature, etc.
- Lack of symmetry in the magnetic circuit. Due to this, driving torque is produced in the disc even with no current flowing through the current coil, and hence the meter creeps.

Errors Caused by Braking System :

- Change in the strength of brake magnet due to variations in temperature etc.
- Self-braking effect of series magnet flux due to overcurrent (or loads).
- Variations in disc resistance with temperature.
- Friction errors at light loads.

Various Adjustments for Compensations of Errors :

There are various adjustments made to the energy meter to overcome the errors mentioned above. They are,

Light Load Adjustment :

This compensation is to overcome the frictional errors, which are high during low loads. During light loads, the torque produced in the disc is insufficient to overcome the frictional torque, which is high during starting rather than running.

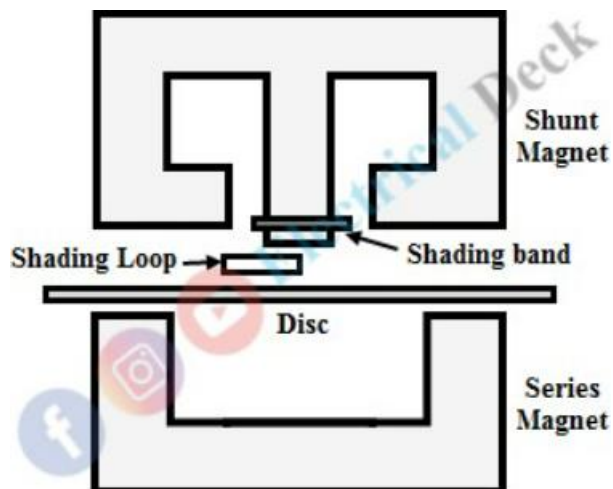

For this compensation, a shading loop is placed in the air gap between the shunt magnet and the disc, so as to cover a region of the center limb and a pole of the shunt magnet as shown in the figure above.

The shading loop is energized proportional to the supply voltage and the field due to this loop produces more starting torque, which is enough to overcome the frictional torque at the starting. Its effect is negligible during running conditions. The starting torque can be adjusted to the required value by the lateral movement of the shading loop.

Creeping Adjustment :

Due to the above friction compensation, the meter may creep sometimes on no-loads. This is because the starting torque provided by the shading loop is irrespective of load current. To compensate this effect, two holes are drilled opposite to each other on the disc. When a hole comes under a pole of shunt magnet, the disc tends to remain stationary in that position.

Instead of drilling holes, a small piece of iron can be placed on the disc and when the iron piece comes near the brake magnet, it is attracted and make the disc stop.

Lag or Power Factor Adjustment :

This compensation is provided to overcome the errors due to incorrect phase angle between the supply voltage and shunt magnet flux ϕ_p . To bring ϕ_p exactly in quadrature with supply voltage two types of lag adjusting devices are available. They are,

- Shading coil
- Shading band

These devices are placed on the center limb of the shunt magnet, so as to link with ϕ_p . The shading coil or lag coil circuit is closed through a low variable resistance, by which the lag angle ϕ_p can be varied. In the case of the shading band, the band is moved along the axis of the shunt magnet to bring ϕ_p in exact quadrature with voltage.

UNIT-III: INSTRUMENT TRANSFORMERS, POTENTIOMETERS, AND MAGNETIC

MEASUREMENTS

Instrument Transformers Basics

Why instrument transformers?

In power systems, currents and voltages handled are very large. Direct measurements are not possible with the existing equipment's. Hence it is required to step down currents and voltages with the help of instrument transformers so that they can be measured with instruments of moderate sizes

Instrument Transformers

- Transformers used in conjunction with measuring instruments for measurement purposes are called "Instrument Transformers".
- The instrument used for the measurement of current is called a "Current Transformer" or simply "CT".
- The transformers used for the measurement of voltage are called "Voltage transformer" or "Potential transformer" or simply "PT".

Instrument Transformers:

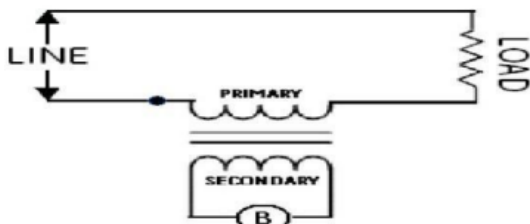

Fig 1. Current Transformer

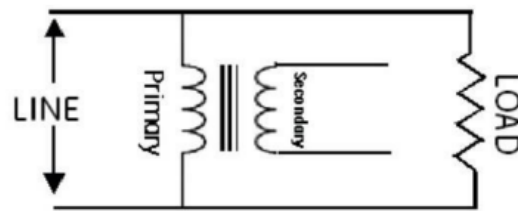

Fig 2. Potential Transformer

Fig 1. Indicates the current measurement by a C.T. The current being measured passes through the primary winding and the secondary winding is connected to an ammeter. The C.T. steps down the current to the level of ammeter.

Fig 2. Shows the connection of P.T. for voltage measurement. The primary winding is connected to the voltage being measured and the secondary winding to a voltmeter. The P.T. steps down the voltage to the level of voltmeter.

Merits of Instrument Transformers:

1. Instruments of moderate size are used for metering i.e. 5A for current and 100 to 120 volts for voltage measurements
2. Instrument and meters can be standardized so that there is saving in costs. Replacement of damaged instruments is easy.

3. Single range instruments can be used to cover large current or voltage ranges, when used with suitable multi range instrument transformers.
4. The metering circuit is isolated from the high voltage power circuits. Hence isolation is not a problem and the safety is assured for the operators
5. There is low power consumption in metering circuit.
6. Several instruments can be operated from a single instrument transformer.

Ratios of Instrument Transformer:

Some definitions are:

Transformation ratio: It is the ratio of the magnitude of the primary phasor to secondary phasor.

$$R = \frac{|\text{Primary phasor}|}{|\text{secondary phasor}|}$$

$R = \text{Primary winding Current} / \text{secondary winding Current}$ for a C.T

$R = \text{Primary Winding Voltage} / \text{Secondary winding Voltage}$ for P.T

Nominal Ratio: It is the ratio of rated primary winding current (voltage) to the Rated secondary winding current (voltage).

$$K_n = \frac{\text{rated primary winding current}}{\text{rated secondary winding current}}$$

$$= \frac{\text{rated primary winding voltage}}{\text{rated secondary winding voltage}} \quad \text{for a P.T.}$$

Turns ratio: This is defined as below

$$n = \frac{\text{number of turns of secondary winding}}{\text{number of turns of primary winding}} \quad \text{for a C.T.}$$

$$= \frac{\text{number of turns of primary winding}}{\text{number of turns of secondary winding}} \quad \text{for a P.T.}$$

Burden of an Instrument Transformer:

The rated burden is the volt ampere loading which is permissible without error exceeding the particular class of accuracy.

$$\begin{aligned} & \text{Total secondary winding burden} \\ &= \frac{(\text{secondary winding induced voltage})^2}{(\text{impedance of secondary winding circuit including impedance of secondary winding})} \\ &= (\text{secondary winding current})^2 \\ & \quad \times (\text{impedance of secondary winding circuit including secondary winding}) \\ \text{secondary winding burden due to load} &= \frac{(\text{secondary winding terminal voltage})^2}{(\text{impedance of load on secondary winding})} \\ &= (\text{secondary winding current})^2 \times (\text{impedance of load in the secondary winding circuit}) \end{aligned}$$

Current Transformer equivalent circuit:

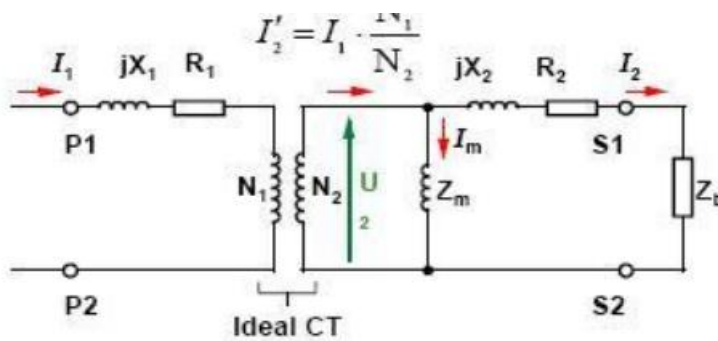

- X1 = Primary leakage reactance
- R1 = Primary winding resistance
- X2 = Secondary leakage reactance
- Z0 = Magnetizing impedance
- R2 = Secondary winding resistance
- Zb = Secondary load

Note: Normally the leakage fluxes X1 and X2 can be neglected

Current transformer, simplified equivalent circuit:

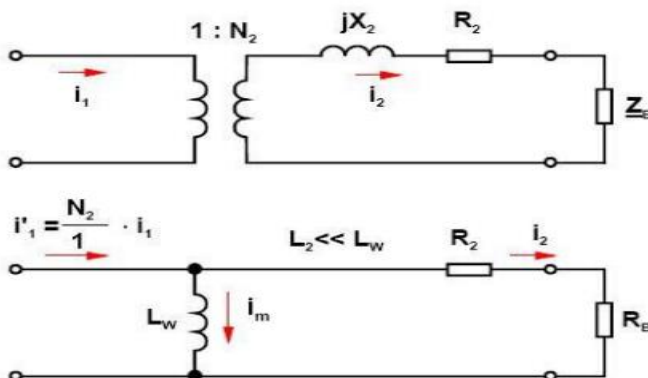

Current transformer: Phase displacement (δ) and current ratio error (ϵ):

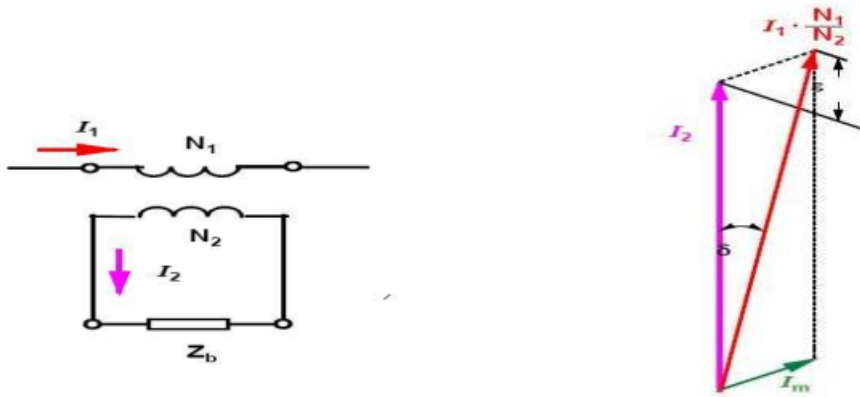

Current Transformer Basics:

Current Transformers (CT's) can be used for monitoring current or for transforming primary current into reduced secondary current used for meters, relays, control equipment and other instruments. CT's that transform current isolate the high voltage primary, permit grounding of the secondary, and step-down the magnitude of the measured current to a standard value that can be safely handled by the instrument.

Ratio : The CT ratio is the ratio of primary current input to secondary current output at full load. For example, a CT with a ratio of 300:5 is rated for 300 primary amps at full load and will produce 5 amps of secondary current when 300 amps flow through the primary. If the primary current changes the secondary current output will change accordingly. For example, if 150 amps flow through the 300 amp rated primary the secondary current output will be 2.5 amps ($150:300 = 2.5:5$).



Window-type



15kV Outdoor CT



15kV Indoor CT

Construction of Current Transformer

Indoor Type	Outdoor Type
indoor units are protected due to their being mounted in an enclosure of some kind	The outdoor unit must be protected for possible contaminated environments
Not Required	outdoor units will have larger spacing between line and ground, which is achieved by the addition of skirts on the Design.
Not Required	For outdoor types the hardware must be of the non-corrosive type and the insulation must be of the non-arc-Tracking type.
The indoor types must be compatible for connection to bus type electrical construction	outdoor types are normally on the pole-top installations.

Circuit connection for current and power measurement using C.T.

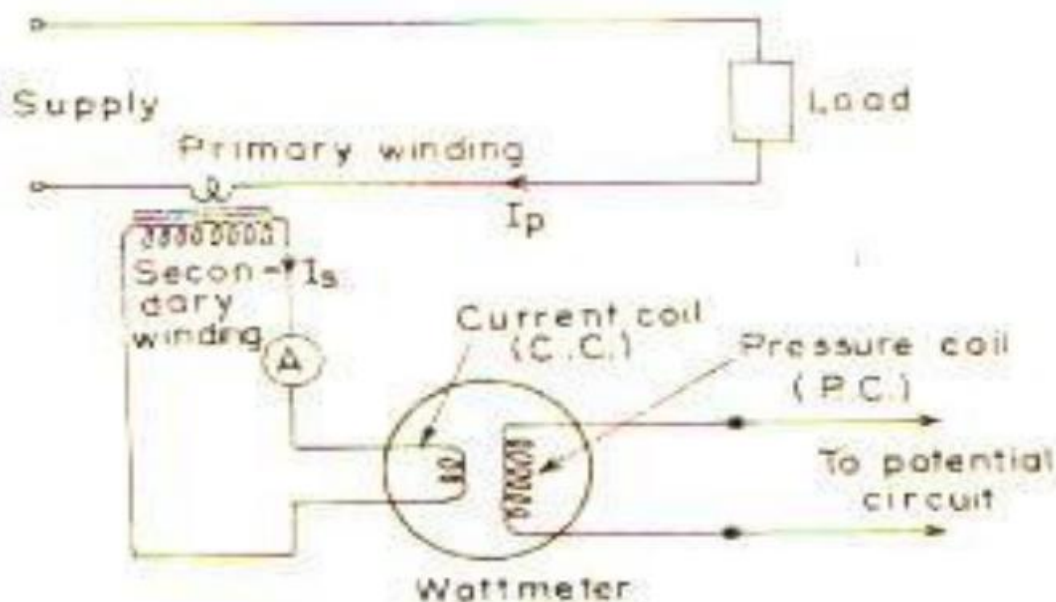

Equivalent Circuit of C.T.

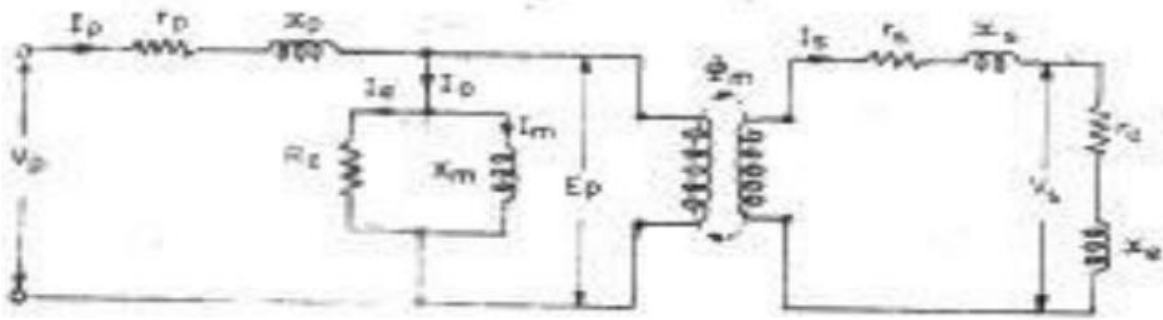

Fig. 1 Equivalent circuit of C.T.

Phasor diagram

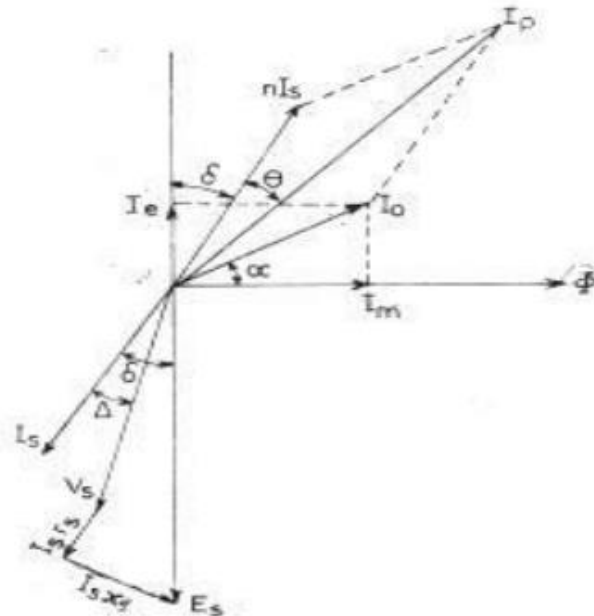

Fig 2. Phasor diagram

A section of Phasor diagram

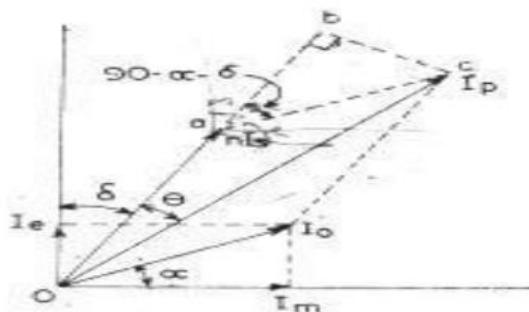

Fig 3. A section of Phasor diagram

Fig 1 represents the equivalent circuit and Fig 2 the phasor diagram of a current transformer.

N = turns ratio = (No. of secondary winding turns)/(No. of primary winding turns)

r_s = resistance of the secondary winding;

x_s = reactance of the secondary winding;

r_e = resistance of external burden i.e. resistance of meters, current coils etc. including leads;

x_e = reactance of external burden i.e. reactance of meters, current coils etc. including leads;

E_p = primary winding induced voltage
 E_s = secondary winding induced voltage
 N_p = No. of primary winding turns;

N_s = No. of secondary winding turns;

V_s = Voltage at the secondary winding terminals
 i_s = secondary winding current;

I_p = primary winding current;

Θ = phase angle of transformer;

secondary winding current = phase angle of total burden including impedance of secondary winding

$$\tan^{-1} \left(\frac{x_s + x_e}{r_s + r_e} \right)$$

= phase angle of secondary winding load circuit i.e. of external burden

I_o = exciting current;

I_m = magnetizing component of exciting current,

I_e = loss component of exciting current,

α = angle between exciting current I_o and working flux ϕ

Consider a small section of the phasor as shown in Fig. 3. we have $\angle bac = 90^\circ - \delta - \alpha$,

$ac = I_o$, $oa = nI_s$ and $oc = I_p$

$bc = I_o \sin(90^\circ - \delta - \alpha) = I_o \cos(\delta + \alpha)$, $ab = I_o$

$\cos(90^\circ - \delta - \alpha) = I_o \sin(\delta + \alpha)$.

Now $(Oc)^2 = (oa + ab)^2 + (bc)^2$

Or

$$\begin{aligned} I_p^2 &= [nI_s + I_0 \sin(\delta + \alpha)]^2 + [I_0 \cos(\delta + \alpha)]^2 \\ &= n^2 I_s^2 + I_0^2 \sin^2(\delta + \alpha) + 2nI_s I_0 \sin(\delta + \alpha) + I_0^2 \cos^2(\delta + \alpha) \\ &= n^2 I_s^2 + 2nI_s I_0 \sin(\delta + \alpha) + I_0^2 \\ \therefore I_p &= [n^2 I_s^2 + 2nI_s I_0 \sin(\delta + \alpha) + I_0^2]^{1/2} \end{aligned} \quad (1)$$

Transformation ratio

$$R = I_p / I_s = [n^2 I_s^2 + 2nI_s I_0 \sin(\delta + \alpha) + I_0^2]^{1/2} / I_s$$

Now in a well-designed current transformer $I_0 \ll nI_s$. Usually I_0 is less than 1 percent of I_p and I_p is, therefore, very nearly equal to nI_s .

Eqn. (2) can be written as

$$R = \frac{[n^2 I_s^2 + 2nI_s I_0 \sin(\delta + \alpha) + I_0^2]^{1/2}}{I_s} = n + \frac{I_0}{I_s} \sin(\delta + \alpha) \quad (3)$$

Phase angle:

The angle by which the secondary current phasor, when reversed, differs in phase from primary current, is known as the —phase angle of the transformer.

+ve if secondary reversed current leads the primary current

-ve if secondary reversed current lags behind the primary current.

The angle between I_s and I_p is θ . Therefore, the phase angle is θ .

From the phasor diagram,

$$\tan \theta = \frac{bc}{ob} = \frac{bc}{oa+ab} = \frac{I_0 \cos(\delta + \alpha)}{nI_s + I_0 \sin(\delta + \alpha)}$$

Now I_0 is very small as compared to nI_s , and, therefore we can neglect the term $I_0(\sin(\delta + \alpha))$

$$\begin{aligned} \therefore \theta &= \frac{I_0 \cos(\delta + \alpha)}{nI_s} \text{ rad} \quad (6) \\ &\approx \frac{I_0 \cos \delta \cos \alpha - I_0 \sin \delta \sin \alpha}{nI_s} \approx \frac{I_m \cos \delta - I_e \sin \delta}{nI_s} \text{ rad} \\ &\approx \frac{180}{\pi} \left(\frac{I_m \cos \delta - I_e \sin \delta}{nI_s} \right) \text{ degree} \end{aligned}$$

Errors in current transformers:

- Turns ratio and transformation ratios are not equal.
- The value of transformation ratio is not constant.

It depends upon:

1. Magnetizing and loss components of exciting current,
2. The secondary winding load current and its power

This introduces considerable errors into current measurement. In power measurement it is necessary that the phase of secondary winding current shall be displaced by exactly 180° from that of the Primary current. Here, phase difference is different from 180° by an angle θ . Hence due to C.T. two types of errors are introduced in power measurements.

Due to actual transformation ratio being different from the turn's ratio.

Due to secondary winding current not being 180° out of phase with the primary winding current.

Ratio error and phase angle error

Ratio Error is defined as:

Percentage ratio error = $\frac{(\text{nominal ratio} - \text{actual ratio})}{(\text{actual ratio})} \times 100$

$$\frac{K_n - R}{R} \cdot 100 \quad (9)$$

Phase angle

$$\approx \frac{180}{3.14} \left(\frac{I_m \cos \delta - I_e \sin \delta}{n I_s} \right)_{\text{degree}}$$

Potential Transformer Basics

Potential transformers are normally connected across two lines of the circuit in which the voltage is to be measured. Normally they will be connected L-L (line-to-line) or L-G (line-to-ground). A typical connection is as follows:

Relationships in a Potential Transformer:

The theory of a potential transformer is the same as that of a power transformer. The main difference is that the power loading of a P.T. is very small and consequently the exciting current is of the same order as the secondary winding current while in a power transformer the exciting current is a very small fraction of secondary winding load current.

Fig 3. and Fig 4. shows the equivalent circuit and phasor diagram of a potential transformer respectively

I_s = secondary winding current,

r_s = resistance of secondary winding

Φ = working flux in wb.

I_m = magnetizing component of no load (exciting) current in

A, I_e = iron loss component of no load (exciting) current in A,

I_0 = no load (exciting) current in A,

E_s = secondary winding induced voltage

V_s = secondary winding terminal voltage,

N_p = primary winding turns

N_s = secondary winding turns

x_s = reactance of secondary winding

r_e = resistance of secondary load circuit

x_e = reactance of secondary load circuit

= phase angle of secondary load circuit

= \tan^{-1}

x_e

$r_e E_p$ = primary winding induced voltage,

I_p = primary winding current

r_p = resistance of primary winding

x_p = reactance of primary winding

Turns ratio $n = N_p / N_s = E_p / E_s$

Secondary voltages when referred to primary side are to be multiplied by n . When secondary currents are referred to primary side, they must be divided by n

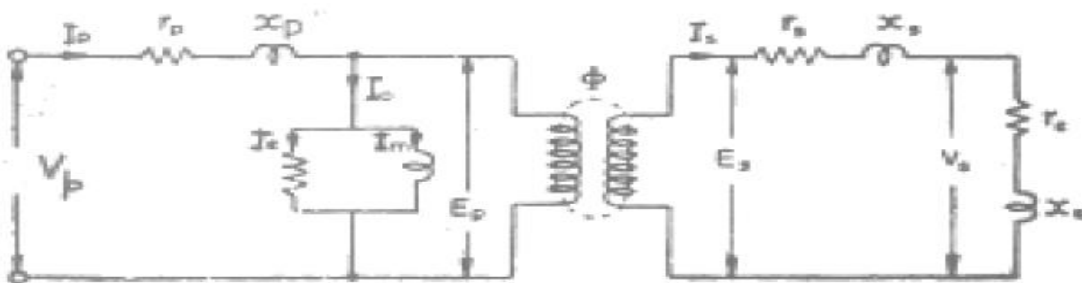

Fig. 3 Equivalent circuit of a P.T.

Actual Transformation ratio

An enlarged concise phasor diagram is shown in Fig. 5.

θ = phase angle of the transformer

= angle between VP and VS reversed

= phase angle of secondary load circuit

= phase angle between IP and VS reversed. Now

$$oa = VP \cos \theta$$

From Phasor diagram

$$oa = n VS + nISrScos + nISxS \sin + IPrP \cos \beta + IPxP \sin \beta$$

Or

$$VP \cos \theta = n VS + nISrScos + nISxS \sin + IPrP \cos \beta + IPxP \sin \beta$$

$$= n VS + nIS (rScos + xS \sin) + IPrP \cos \beta + IPxP \sin \beta \dots\dots(i)$$

Phase angle θ is very small and, therefore, both VP and VS reversed can be taken perpendicular to Φ and, hence

$$\angle ocd \approx \beta \text{ (approximately) and } \angle ecd \approx \theta \text{ (approximately).}$$

$$\text{Thus } IP \cos \beta = I_e + (IS/n) \cos$$

$$IP \sin \beta = I_m + (IS/n) \sin$$

Now θ is very small usually less than 1° and therefore, $\cos \theta = 1$,

hence we can write: $VP \cos \theta = VP$

Substituting the above values in (i), we have:

$$VP = n VS + nIS (rScos + xS \sin) + (I_e + (IS/n) \cos) R_p + (I_m + (IS/n) \sin) X_p$$

$$= n VS + I_S \cos (n r_S + r_p/n) + I_S \sin (n x_S + x_p/n) + I_e r_p + I_m X_p \dots\dots(ii)$$

$$= n VS + (I_S/n) \cos (n^2 r_S + r_p) + (I_S/n) \sin (n^2 x_S + x_p) + I_e r_p + I_m X_p$$

$$= n VS + (I_S/n) \cos R_p + (I_S/n) \sin X_p + I_e r_p + I_m X_p$$

$$= n VS + (I_S/n) (R_p \cos + X_p \sin) + I_e r_p + I_m X_p \dots\dots(iii) \text{ Here}$$

R_p = equivalent resistance of the transformer referred to the primary side = $n^2 r_S + r_p$

and X_p = equivalent reactance of the transformer referred to the primary side = $n^2 x_S + x_p$

Actual transformation (voltage) ratio $R = V_P / V_S$

$$= n + \frac{((I_S/n) (R_p \cos + X_p \sin) + I_e r_p + I_m X_p)}{V} \dots\dots(iv)$$

Eqn (ii) may be written as:

$$V_P = n V_S + n I_S \cos(\theta) (r_S + r_P/n^2) + n I_S \sin(\theta) (x_S + x_P/n^2) + I_e r_P + I_m x_P$$

$$V_P = n V_S + n I_S \cos(\theta) R_S + n I_S \sin(\theta) X_S + I_e r_P + I_m x_P$$

$$= n V_S + n I_S (R_S \cos(\theta) + X_S \sin(\theta)) + I_e r_P + I_m x_P \dots\dots(v)$$

Where

R_S = equivalent resistance of transformer referred to secondary side = $r_S + r_P/n^2$

X_S = equivalent reactance of transformer referred to secondary side = $x_S + x_P/n^2$.

Actual transformation (voltage) ratio $R = V_P / V_S$

$$= n + \frac{n I_S (R_S \cos(\theta) + X_S \sin(\theta)) + I_e r_P + I_m x_P}{V_S} \dots\dots(vi)$$

Using eqns. (iii) and (v), the difference between actual transformation ratio and turns ratio is:

$$R - n = \frac{(I_S/n) (R_P \cos(\theta) + X_P \sin(\theta)) + I_e r_P + I_m x_P}{V_S} \dots\dots(vii)$$

$$= \frac{n I_S (R_S \cos(\theta) + X_S \sin(\theta)) + I_e r_P + I_m x_P}{V_S} \dots\dots(viii)$$

$$\tan \theta = \frac{ab}{oa} = \frac{I_P x_P \cos \beta - I_P r_P \sin \beta + n I_S x_S \cos \theta - n I_S r_S \sin \theta}{n V_S + n I_S r_S \cos \theta + n I_S x_P \sin \theta + I_P r_P \cos \beta + I_P x_P \sin \beta}$$

The terms in the denominator involving I_P and I_S are small and, therefore, they can be neglected as compared with $n V_S$.

$$= \frac{I_P x_P \cos \beta - I_P r_P \sin \beta + n I_S x_S \cos \theta - n I_S r_S \sin \theta}{n V_S}$$

$$= \frac{I_S \cos \theta \left(\frac{x_P}{n} + n^2 x_S \right) - I_S \sin \theta \left(\frac{r_P}{n} + n^2 r_S \right) + I_e x_P - I_m r_P}{n V_S}$$

Since θ is small, $\theta = \tan \theta$

$$\begin{aligned} \therefore \theta &= \frac{\frac{I_s}{n} (X_p \cos - R_p \sin) + I_e X_p - I_m r_p}{n V_s} \text{ rad} . \\ &= \frac{I_s}{V_s} (X_s \cos - R_s \sin) + \frac{I_e X_p - I_m r_p}{n V_s} \text{ rad} \end{aligned}$$

Errors in potential transformers

Ratio error (Voltage Error):

The actual ratio of transformation varies with operating condition and the error in secondary voltage may be defined as,

$$\% \text{ Ratio Error} = K_n - R \times 100$$

Phase angle error:

In an ideal voltage transformer, there should not be any phase difference between primary winding voltage and secondary winding voltage reversed. However, in an actual transformer there exists a phase difference between VP and VS reversed.

$$\begin{aligned} \therefore \theta &= \frac{\frac{s}{n} (X_p \cos - R_p \sin) + I_e X_p - I_m r_p}{n V_s} \text{ rad} . \\ &= \frac{I_s}{V_s} (X_s \cos - R_s \sin) + \frac{I_e X_p - I_m r_p}{n V_s} \text{ rad} \end{aligned}$$

DC POTENTIOMETER

A potentiometer is one of the most fundamental instruments of electrical instruments. The potentiometer measures voltage or potential difference by comparing an unknown voltage with a known voltage. Unlike the AC potentiometer, the DC potentiometer compares only the magnitude of unknown voltage with the known voltage.

A DC potentiometer can be used to measure the current, resistance, and power. If time can be measured then one can easily calculate the energy by multiplying the power with the time by the DC potentiometer. The potentiometer is also used for calibration of voltmeter, ammeter, and wattmeter.

Working principle of dc potentiometer

The working principle slide wire dc potentiometer is the same as the ac potentiometer, where the dc potentiometer compares the voltage of an unknown source with a source whose voltage is known. The circuit diagram is shown below:

Disadvantages

- Its operation is very time consuming

Applications of dc potentiometer

Calibration of voltmeter

Calibration of ammeter

Calibration of wattmeter

Measurement of current

The unknown current I , whose value is to be measured is passed through a resistor R . The value of the resistor is such that voltage drop across it may not exceed the range of the potentiometer.

The circuit diagram of current measurement by potentiometer is shown below:

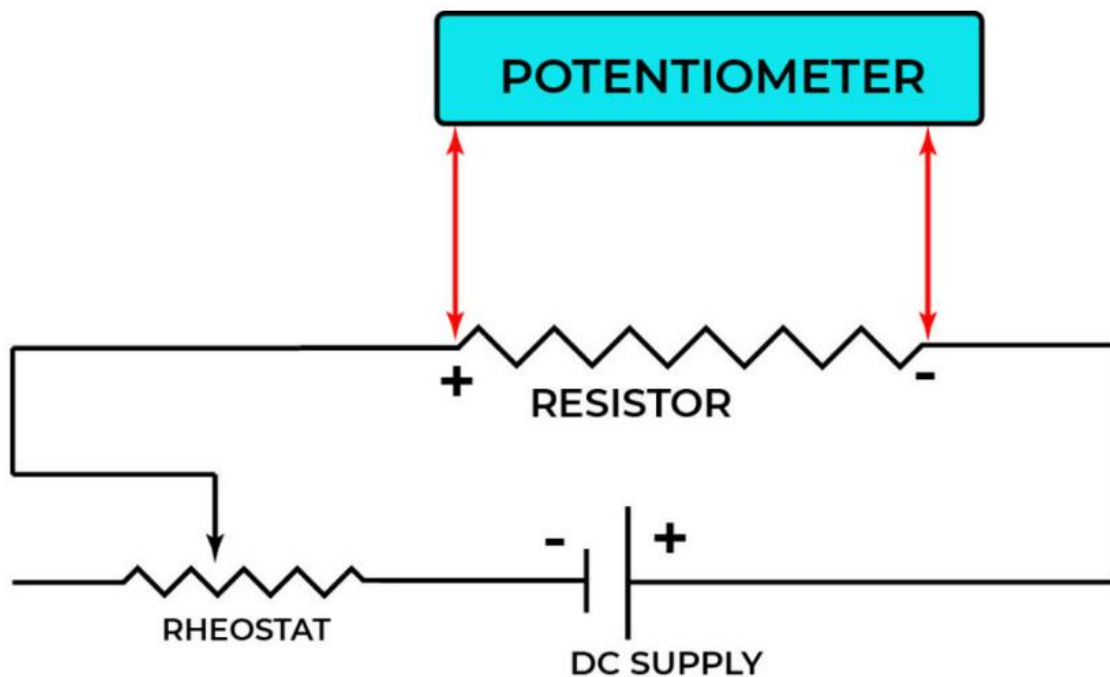

So, the value of the unknown current is the voltage drop across the resistor divided by the value of the resistor.

Measurement of unknown Resistance

An unknown resistance is connected in series with a standard resistance S . A rheostat controls the current in the circuit. A two-pole double throw switch is also used in the circuit. The circuit is shown below:

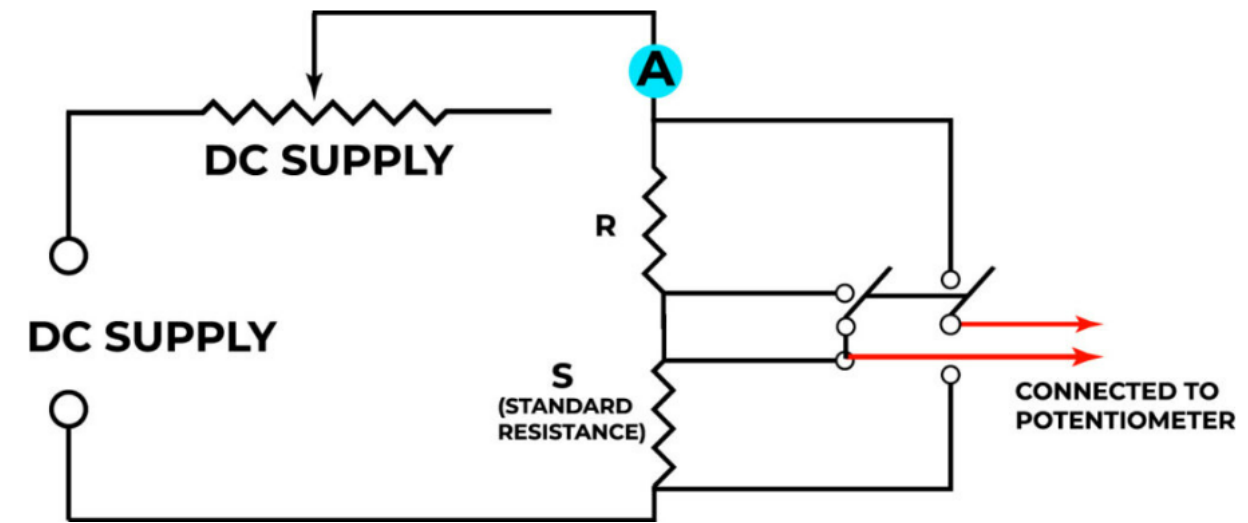

When the two poles double throw switch is put in position 1, the unknown resistance is connected to the potentiometer.

Let the reading of the potentiometer be V_R

$$V_R = IR \quad (i)$$

Now the switch is put in position 2, this connects the standard resistor S to the potentiometer.

Let the reading of potentiometer be V_s

$$V_s = IS \quad (ii)$$

From i and ii

$$V_R/V_s = IR/IS$$

$$R = (V_R/V_s) \cdot S$$

The value of R is calculated accurately.

AC Potentiometer

Definition: The potentiometer which is used for measuring the phase and the magnitude of the unknown emf by comparing it with the known emf such type of potentiometer is known as the AC potentiometer. The working principle of the AC potentiometer is same as that of the DC potentiometer, i.e., the unknown voltage is determined by comparing it with the known voltage. And when both of them are equal the galvanometer indicates the null point. Hence the value of the unknown emf is known.

The operation of the AC potentiometer is quite complicated as compared to the DC potentiometer. The following are the important factor which must be considered for their operation.

1. In AC potentiometer, the frequency and the waveform of the current must be same as that of the voltage being measured. Thus, in AC potentiometer the potential is transferred from the same source as the current or voltage is measured.

2. The non-inductive element is used for making the sliding wire and the resistance coil of the AC potentiometer which reduces the reading error.
3. The reading of the AC potentiometer is affected by the external magnetic field. So, they are eliminated at the time of measurement.
4. The supply source should be sinusoidal and free from harmonics because in the presence of the harmonics the balanced is not easily achieved.

Types of AC Potentiometer

The AC potentiometers are classified by the value measured by the potentiometer dial and scales. The AC potentiometer may be broadly classified as.

Polar Type Potentiometer

In this potentiometer, the magnitude of the unknown voltage is measured from one scale, and its phase angle is directly on the second scale. The arrangement is made to read phase angles up to 360° . The voltage is read in the form of $V \angle \theta$.

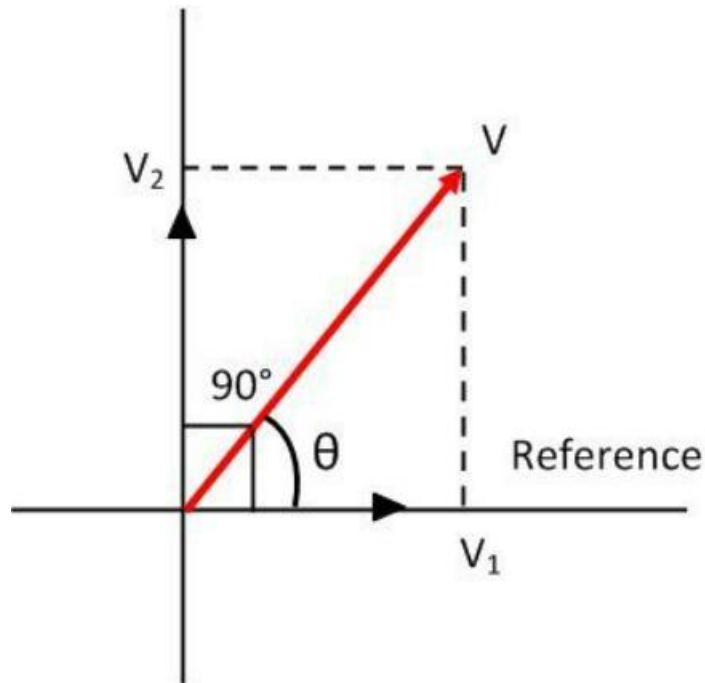

Phasor diagram for Polar type Potentiometer

Circuit Globe

Coordinate Type Potentiometer

The coordinate type potentiometer has two scales to read the inphase V_1 component, and the quadrature component V_2 of the unknown voltage V . These voltages are 90° out of phase with each other. The potentiometer is constructed in such a way so that the potentiometer read both the positive and negative value of V_1 and V_2 and covered all the angle up to 360° .

Applications of Potentiometer

The AC potentiometer has numerous applications. The few of them are explained below:

- 1. Voltmeter Calibration** – The AC potentiometer directly measures the low voltages up to 1.5V. The higher voltage is measured by either using the volt box ratio or two capacitors in series with the potentiometer.
- 2. Ammeter Calibration** – The measurement of the alternating current may be measured by the use of non-inductive standard resistor with the potentiometer.
- 3. Wattmeter and Energy Meter Testing** – The testing circuit of the Wattmeter and the energy meter is same as that of the DC measurements. The phase shifting transformer is connected to the potentiometer to vary the phase of the voltage on the current. Thus, the voltage and current may vary at different power factor.
- 4. Measurements of Self Reactance of a Coil** – The standard reactance is placed in series with the coil whose reactance is to be measured.

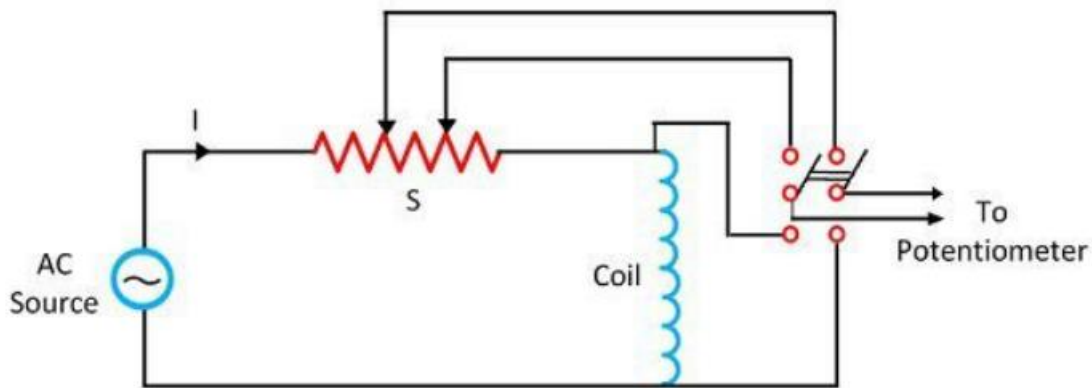

Measurement of Self Reactance of Coil

- 5. Other Applications** – The AC potentiometer is used for engineering measurement in which the accuracy of 0.5 to 1% is essential. The AC potentiometer is also used for measuring the voltage which must be resolved into two components. It gives the accurate results in magnetic testing and precise testing of instrument transformers.

Determination of B-H curve and Hysteresis Loop

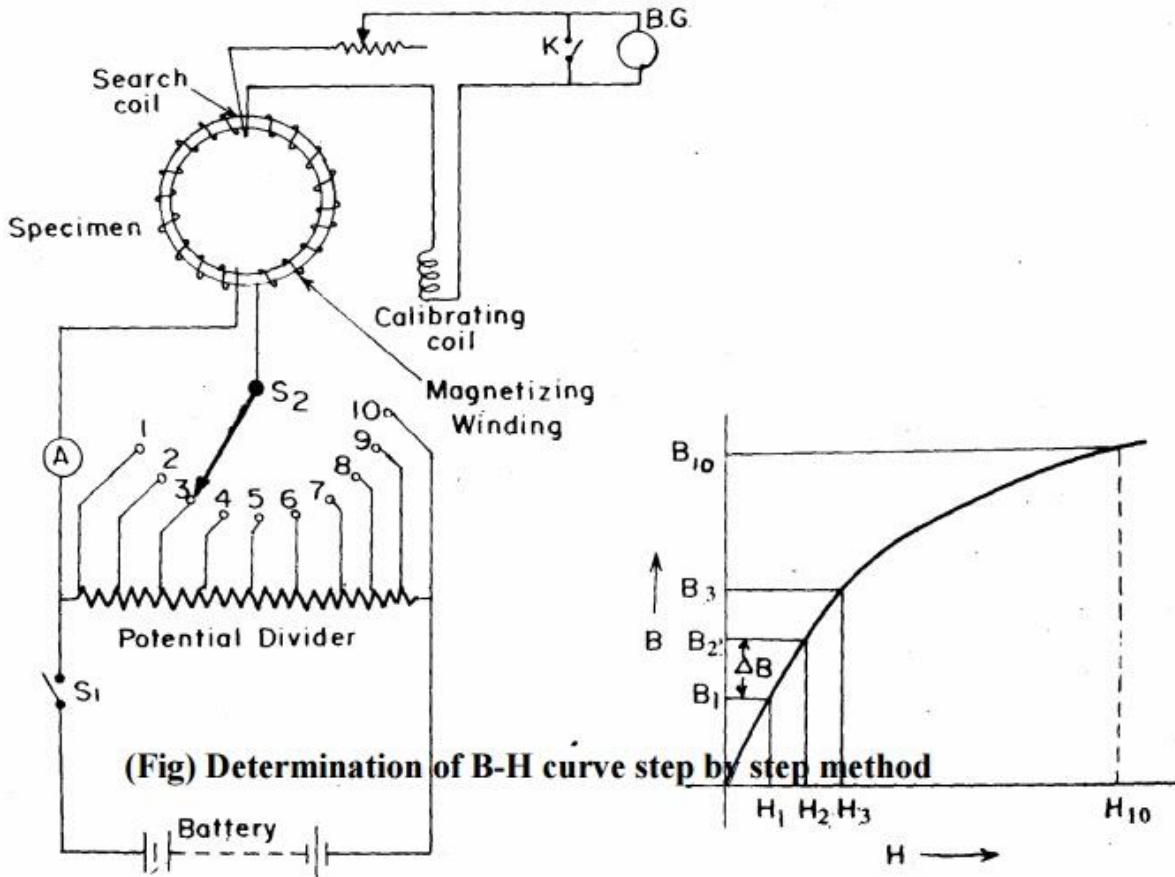

Method of reversals

A ring shaped specimen whose dimensions are known is used for the purpose

After demagnetizing the test is started by setting the magnetising current to its lowest test plane.

With galvanometer key K closed, the iron specimen is brought into a 'reproducible cyclic magnetic state' by throwing the reversing switch S backward and forward about twenty times.

Key K is now opened and the value of flux corresponding to this value of H is measured by reversing the switch S and noting the throw of galvanometer.

The value of flux density corresponding to this H can be calculated by dividing the flux by the area of the specimen.

The above procedure is repeated for various values of H up to the maximum testing point.

The B-H curve may be plotted from the measured values of B corresponding to the various values of H .

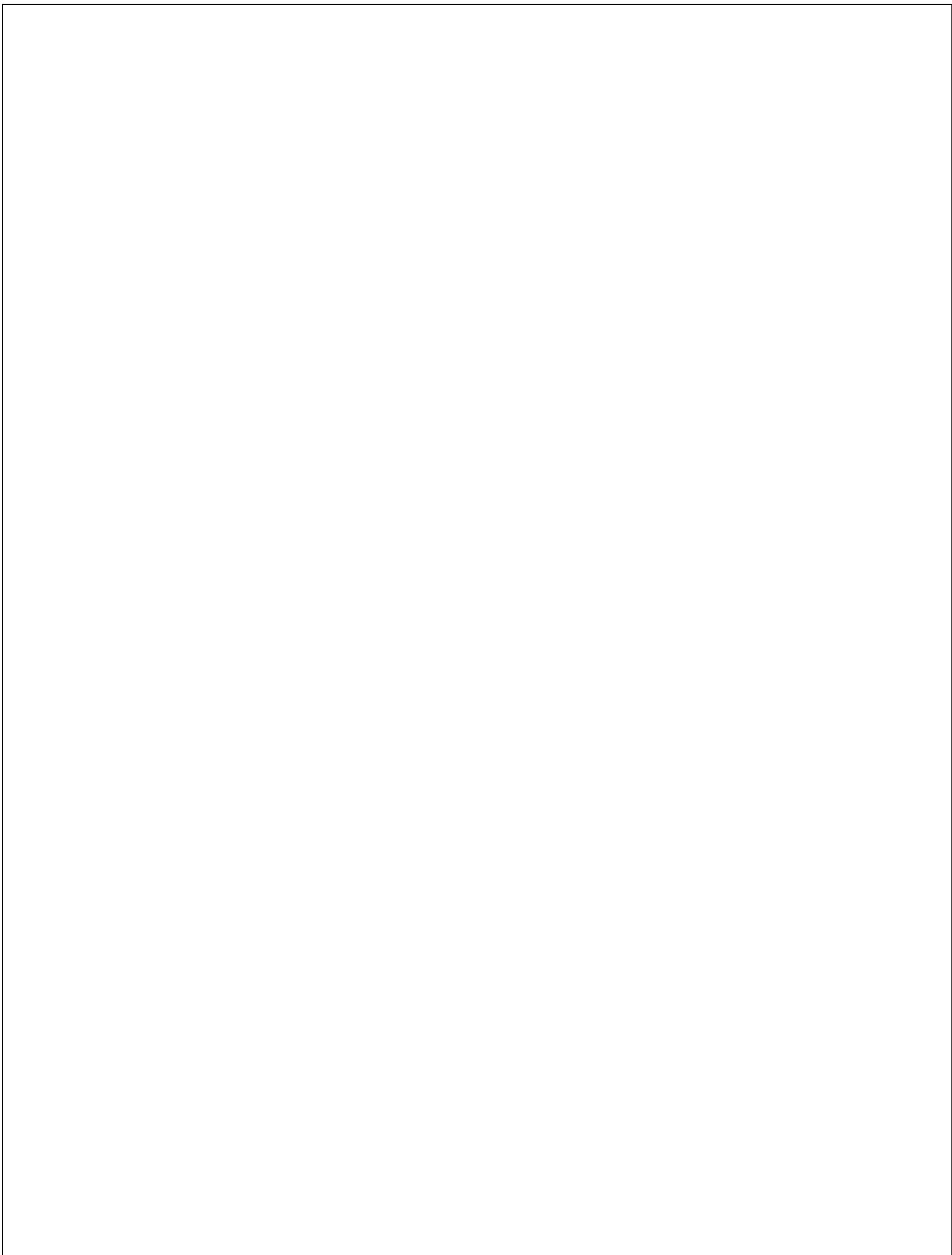

UNIT-IV : D.C & A.C BRIDGES

Measurement of Low, Medium & High Resistance:

Resistance is one of the important parameter in electrical parameters. Thus it is essential to know the resistance of any circuit to understand the behavior of any element in the circuit. Measurement of resistance is also used for the measurement of other electrical quantities. Depending upon the value of resistance they are classified into three categories,

- Low Resistance - Resistance of the order of 1Ω and below are classified as low resistance.
- Medium Resistance - Resistance ranging from 1Ω to 100Ω are classified as medium resistances
- High Resistance - Resistance of the order of $100k\Omega$ and above are classified as high resistances

Even though there are multimeters for the measurement of resistance. In order to obtain accurate value, suppose if the resistance is very low and very high various methods are implemented. Hence for the measurement of resistance, the above classification is done and different techniques are applied for low, medium, and high values of resistances.

Wheatstone Bridge

Definition: Wheatstone bridge is a type of dc bridge that is used for the measurement of unknown resistance. It is a series-parallel combination of 4 resistances that provides zero difference voltage at the balanced condition. The principle of null indication is the basis of working of Wheatstone bridge and thus provides high accuracy in measurements.

It consists of four resistances, out of which 2 are known resistances, one is variable resistance that is used to balance the bridge and another one is unknown resistance whose value is to be measured.

Under the balanced condition, the ratio of the values of two known resistances becomes equivalent to the ratio of the variable resistance and the unknown resistance value. Thus, allows us to calculate the unknown value of the resistance employed in the electrical circuit.

Circuit construction and theory of Wheatstone bridge

The figure below shows the general circuit of the Wheatstone bridge. It consists of 4 arms namely AC, AD, BC and BD each containing resistance R_1 , R_2 , R_3 and R_4 . Here, R_2 is the variable resistance and R_4 is the unknown resistance.

A galvanometer is placed at one arm which detects the flow of current through the circuit on providing the supply voltage at another arm of the circuit.

Let us see how unknown resistance can be calculated in balanced condition of a Wheatstone bridge.

In the absence of any current through the galvanometer, the bridge gets balanced. In other words, the bridge gets balanced when the voltage difference between the two points C and D are equal. Thus, providing 0 voltage across the galvanometer.

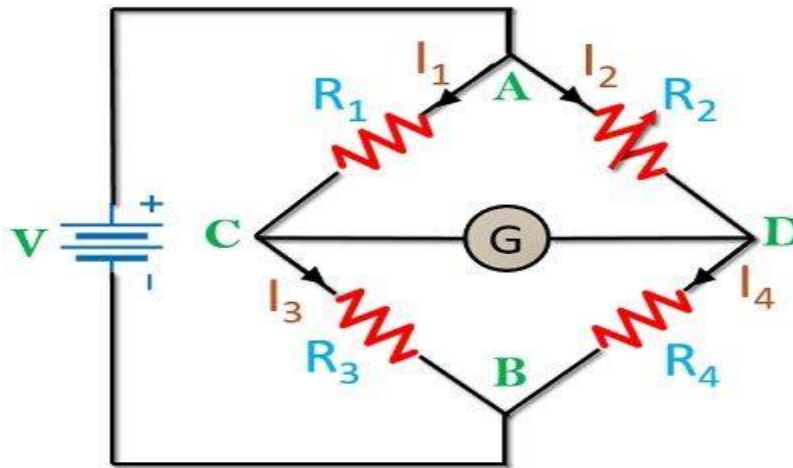

Wheatstone bridge circuit

Electronics Coach

Sensitivity of Wheatstone bridge

The sensitivity of a Wheatstone bridge is defined as the deflection in the galvanometer per unit current. In the unbalanced condition of the bridge, when current flows, it causes the pointer of galvanometer to get deflected. Thus, the deflection rate is the function of sensitivity.

A greater amount of deflection can be noticed for the same current in case of a more sensitive galvanometer. The total deflection D is given as

$$D = S \times I$$

S is sensitivity and I is current in microamps.

Applications of Wheatstone bridge

It is used to measure dc resistance.

Wheatstone bridge is widely used in cable faults identification by telephone companies.

It can measure physical quantities like light, temperature etc when used with an op-amp.

By some modulation to bridge network, we can calculate capacitance, inductance and impedance.

Limitations of Wheatstone bridge

- In Wheatstone bridge sometimes measurements of low resistance generate erroneous results. Thus, Kelvin's double bridge was introduced to overcome this.
- It is always preferable to measure medium resistances with Wheatstone bridge as for high resistance measurements it is not suitable. This is so because in case of high resistance the galvanometer is not sensitive to imbalance.

- The heating effect due to the current in the circuit unnecessarily changes the resistances employed in it. This sometimes causes a permanent change in resistance due to a large current in the circuit.

Thus, from the above discussion, we can conclude that dc bridges that operate on dc supply allow us to determine the unknown resistance. However, an ac bridge allows us to measure resistance, inductance and capacitance when fed with an ac source.

Kelvin Double Bridge for Low resistance measurement

Kelvin's double bridge may be used for precision measurement of four-terminal low resistances. Four terminal resistors have two current leading terminals and two potential terminals across which the resistance equals the marked nominal value. This is because, the current must enter and leave the resistor in a fashion that there is same or equivalent distribution of current density between the particular equipotential surfaces used to define the resistance. The additional points also eliminated any contact resistance at the current lead-in terminals.

Circuit Diagram:

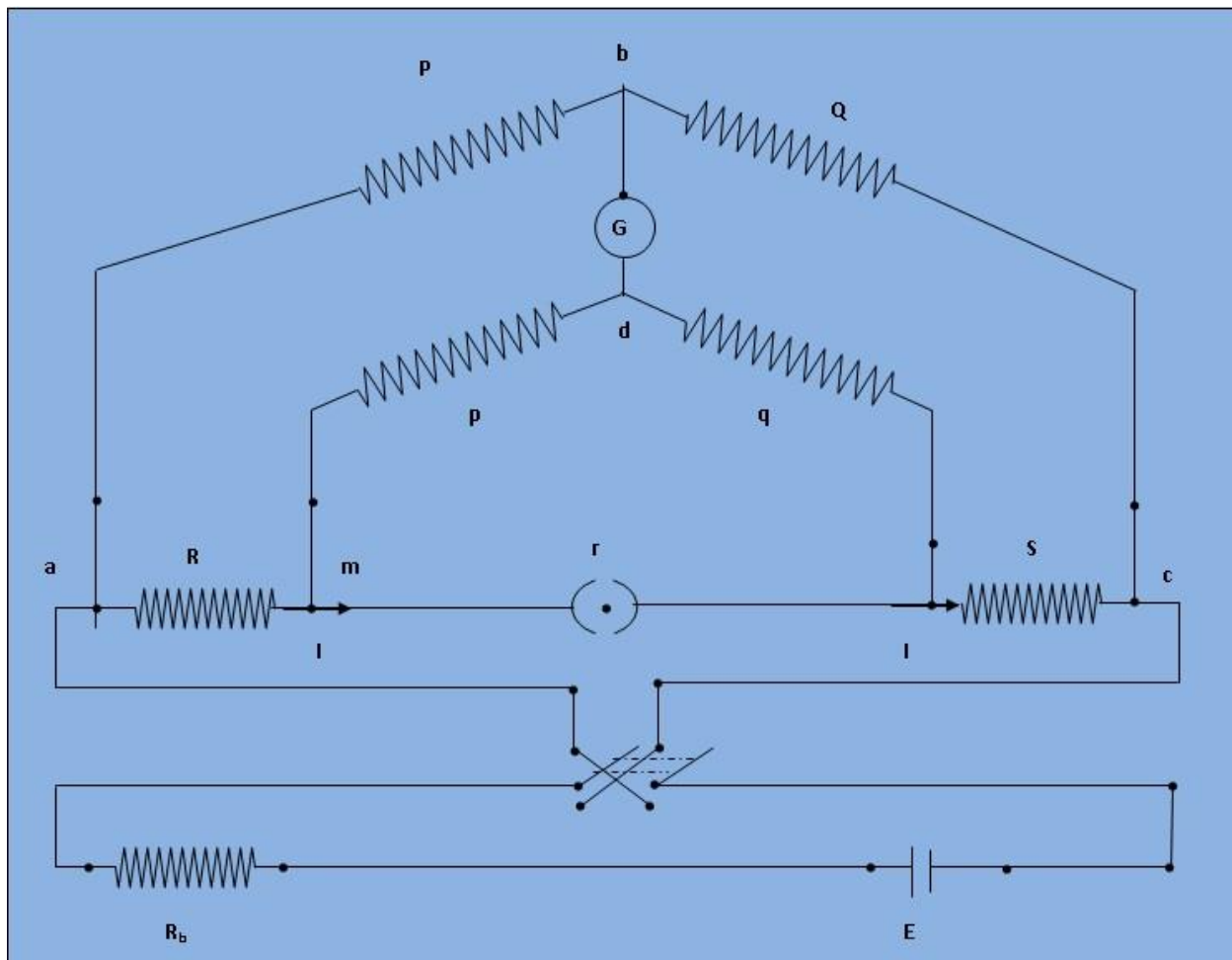

Fig : Schematic diagram for measurement of low resistance by Kelvin double bridge

The kelvin double bridge incorporates the idea of a second set of ratio arms - hence the name double bridge- and the use of four terminal resistors for the low resistance arms. Figure 1 shows the schematic diagram of kelvin bridge. The first ratio arms is P and Q. The second set of ratio arms p and q is used to connect the galvanometer to a point d at the appropriate potential between points m and n to eliminate the effect of connecting lead resistance r between the unknown resistance R and the standard resistance S.

The ratio p/q is made equal to P/Q. Under balance conditions there is no current through the galvanometer which means that the voltage drop between a and b, E_{ab} is equal to voltage drops E_{amd} between a and c.

$$E_{ab} = P \cdot \frac{E_{ac}}{P+Q} \text{ and } E_{ac} = I \cdot \left\{ R + S + r \cdot \frac{p+q}{p+q+r} \right\}$$

$$E_{amd} = I \cdot \left\{ R + \left(\frac{p}{p+q} \right) \cdot \left(r \cdot \frac{p+q}{p+q+r} \right) \right\} = I \cdot \left(R + p \frac{r}{p+q+r} \right)$$

for zero galvanometer deflection, $E_{ab}=E_{amd}$

$$\frac{PI}{P+Q} \left[R+S + \frac{(p+q)r}{p+q+r} \right] = I \left[R + \frac{pr}{p+q+r} \right]$$

$$\text{or } R = \frac{P}{Q}S + \frac{qr}{p+q+r} \left[\frac{P}{Q} - \frac{p}{q} \right] \text{ ----- (1)}$$

$$\text{now if } \frac{P}{Q} = \frac{p}{q} \text{ Eq (1) becomes, } R = \frac{P}{Q}S \text{ ----- (2)}$$

Eq (2) is the usual working equation for the kelvin bridge. It indicates that the resistance of connecting lead, r, has no effect on the measurement, provided that the two sets of ratio arms have equal ratios.

Measurement of High Resistances

The following methods are employed for the measurement of high resistances –

1. Direct Deflection Method
2. Loss of Charge Method
3. Megohm Bridge
4. Megger

Direct Deflection Method

In this method, a very sensitive and high resistance (more than 1 kΩ) PMMC galvanometer is connected in series with the resistance to be measured and to a battery. The deflection of galvanometer gives the measure of unknown resistance. This method is mainly used for the measurement of insulation resistance.

Let us take an example of direction deflection method for measuring insulation resistance of a cable.

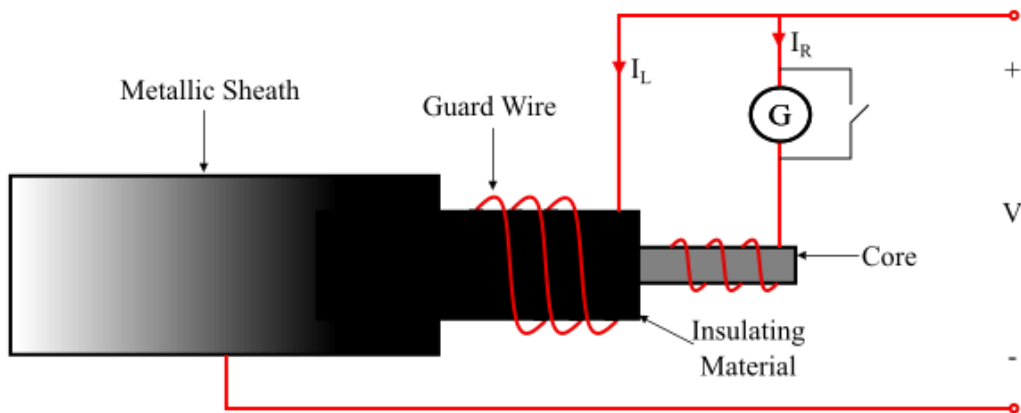

Refer the figure, the galvanometer (G) measures the current I_R between conductor core and metal sheath. The leakage current I_L over the surface of insulating material is carried by the guard wire wound on the insulation and does not flow through the galvanometer. Thus, the resistance of the cable is,

$$R = \frac{V}{I_R} \dots (1)$$

Loss of Charge Method

The circuit arrangement for this method consists of a known capacitor (C), an electrostatic voltmeter (V) and an unknown resistance R_x .

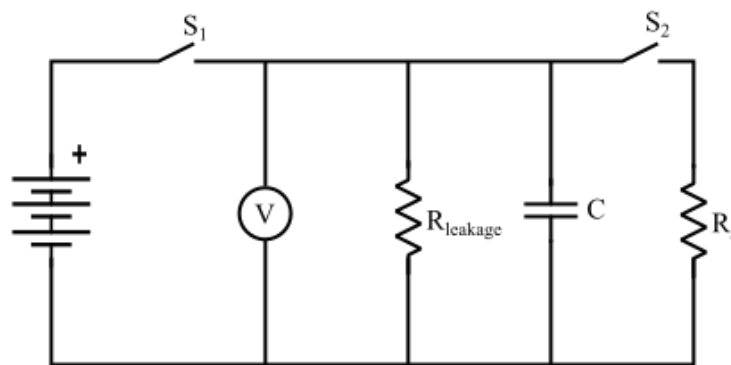

Step 1 – By closing the switch (S_1), the capacitor (C) being charged by connecting a battery across it to a specific voltage.

Step 2 – Now, open the switch (S_1) and close switch (S_2), the capacitor is discharged through R_x and $R_{leakage}$. The time taken (t) for the potential difference to fall from V_1 to V_2 during discharge is observed by a stop watch.

From the circuit, the Req. is the effective resistance of Rx and Rleakage which are parallel connected.

$$\frac{1}{R_{eq.}} = \frac{1}{R_x} + \frac{1}{R_{leakage}}$$

As the discharging voltage equation of the capacitor is given by,

$$V_2 = V_1 e^{-t/CR_{eq.}} \dots (2)$$

From the eqn. (2), Req. can be determined. Thus, by knowing the value of Req. and Rleakage, the value of unknown resistance Rx can be determined as

$$\frac{1}{R_x} = \frac{1}{R_{eq.}} - \frac{1}{R_{leakage}} \dots (3)$$

Megohm Bridge

The circuit of Megohm bridge consists of power supplies, resistances, amplifiers and indicating instruments.

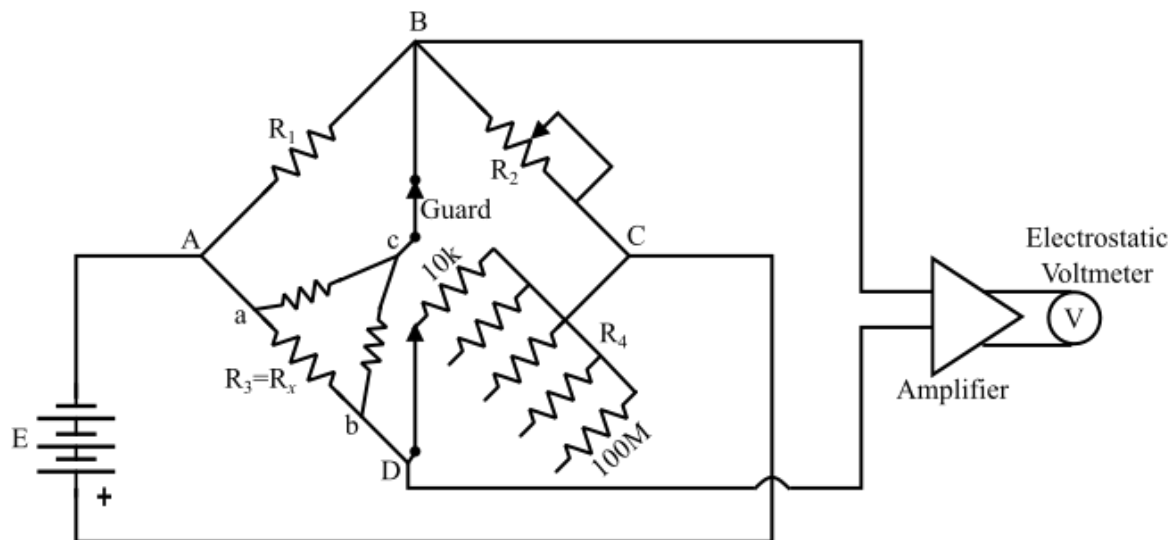

In this instrument, the dial on R2 is calibrated 1-10-100-1000 MΩ and the R4 gives five multipliers 0.1, 1, 10, 100 and 100. The junction of R1 and R2 is brought on the main panel and assigned a name as Guard terminal. The unknown resistance is given by,

$$R_3 = \frac{R_1 R_4}{R_2} \dots (4)$$

Megger

Megger (megohmmeter) is a device used for the measurement of high resistances, mainly insulation resistances of electric circuits with respect to earth or one another. A megger consists of a source of emf and a voltmeter whose scale is usually calibrated in mega-ohms. The unknown resistance R_x has to be connected across the leads of megger.

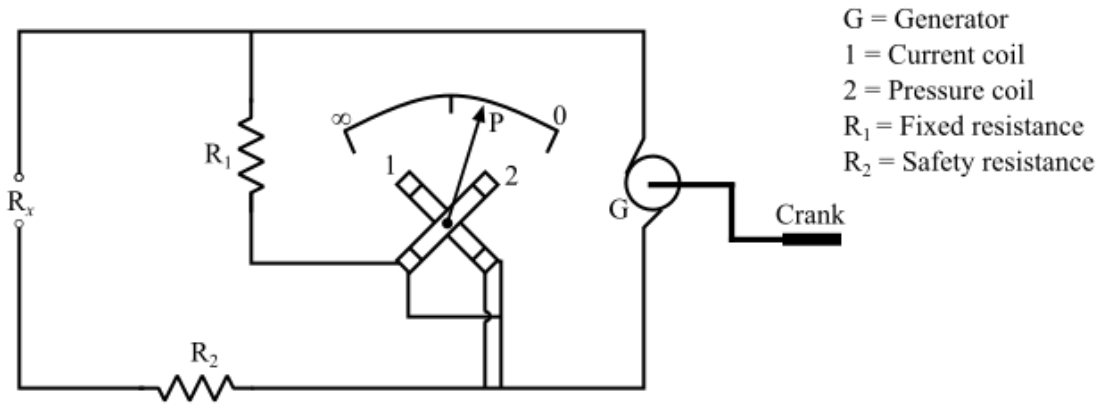

When the megger operates, the deflection of the moving system depends upon the ratio of the applied voltage and the current in the coils of the megger. The unknown resistance is read directly from the scale of the megger.

Loss of Charge Method

- In 'Loss of charge method' the insulation resistance R to be measured is connected in parallel with a capacitor C and an electrostatic voltmeter.
- The capacitor is charged to some suitable voltage, by means of a battery having voltage V and is then allowed to discharge through the resistance.
- The terminal voltage is observed over a considerable period of time during discharge.
- Hence We can measure **High resistance by using the Loss of charge method.**

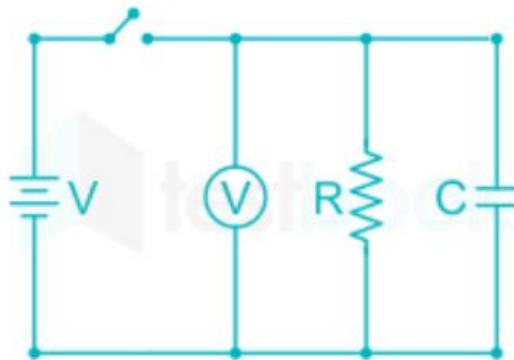

The voltage across the capacitor at any instant t after the application of voltage is,

$$V_c = V e^{-\left(\frac{t}{RC}\right)}$$

$$\Rightarrow V = V_c e^{\frac{t}{RC}}$$

Maxwell Bridge:

Maxwell bridge is an ac bridge used to measure an unknown inductance in terms of a known capacitance. A Maxwell bridge is a modification to a Wheatstone bridge used to measure an unknown inductance (usually of low Q value) in terms of calibrated resistance and inductance or resistance and capacitance. When the calibrated components are a parallel resistor and capacitor, the bridge is known as a Maxwell-Wien bridge. It is named for James C. Maxwell, who first described it in 1873.

It uses the principle that the positive phase angle of an inductive impedance can be compensated by the negative phase angle of a capacitive impedance when put in the opposite arm and the circuit is at resonance; i.e., no potential difference across the detector (an AC voltmeter or ammeter) and hence no current flowing through it. The unknown inductance then becomes known in terms of this capacitance

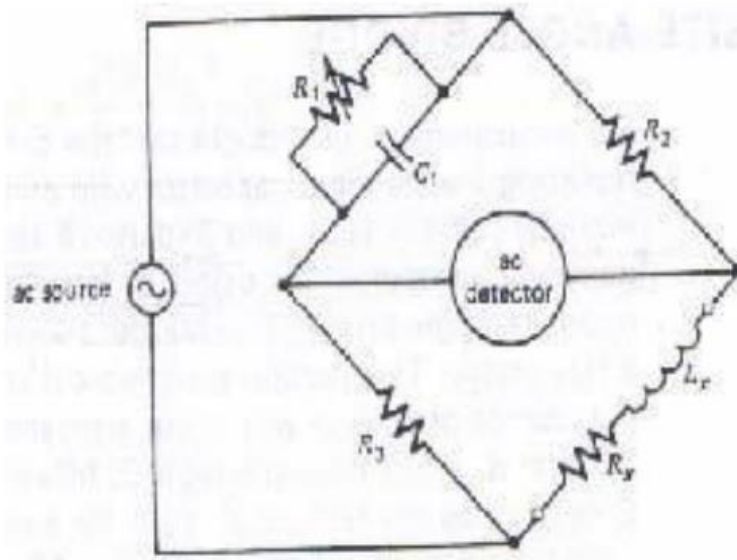

Using capacitance as a standard has several advantages due to:

- Capacitance of capacitor is influenced by less external fields.
- Capacitor has small size.
- Capacitor is low cost.

The impedance of the arms of the bridge can be written as

$$Z_1 = \frac{1}{\frac{1}{R_1} + j\omega C_1}$$

The general equation for bridge balance is

$$Z_2 = R_2$$

$$Z_3 = R_3$$

$$Z_4 = R_x + j X_{Lx}$$

Equating real terms and imaginary terms we have

$$R_x = \frac{R_2 R_3}{R_1}$$

$$j\omega L_x = j\omega R_2 R_3 C_1$$

$$L_x = R_2 R_3 C_1$$

A practical issue in construction of the bridge is mutual inductance: two inductors in proximity will give rise to mutual induction: when the magnetic field of one intersects the coil of the other, it will reinforce the magnetic field in that other coil, and vice versa, distorting the inductance of both coils. To minimize mutual inductance, orient the inductors with their axes perpendicular to each other, and separate them as far as is practical. Similarly, the nearby presence of electric motors, chokes and transformers (like that in the power supply for the bridge!) may induce mutual inductance in the circuit components, so locate the circuit remotely from any of these.

The additional complexity of using a Maxwell-Wien bridge over simpler bridge types is warranted in circumstances where either the mutual inductance between the load and the known bridge entities, or stray electromagnetic interference, distorts the measurement results. The capacitive reactance in the bridge will exactly oppose the inductive reactance of the load when the bridge is balanced, allowing the load's resistance and reactance to be reliably determined.

Anderson's Bridge:

The Anderson's bridge gives the accurate measurement of self-inductance of the circuit. The bridge is the advanced form of Maxwell's inductance capacitance bridge. In Anderson bridge, the unknown inductance is compared with the standard fixed capacitance which is connected between the two arms of the bridge.

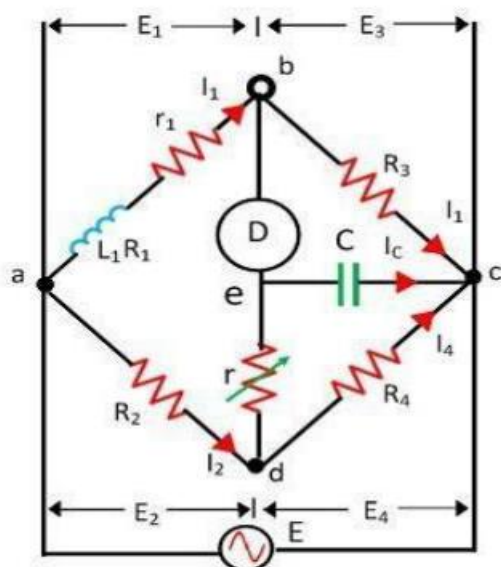

The bridge has four arms ab, bc, cd, and ad. The arm ab consists of unknown inductance along with the resistance. And the other three arms consist of purely resistive arms connected in series with the circuit.

The static capacitor and the variable resistor are connected in series and placed in parallel with the cd arm. The voltage source is applied to the terminals a and c.

Phasor Diagram:

The phasor diagram of the Anderson bridge is shown in the figure below. The current I_1 and the E_3 are in phase and represented on the horizontal axis. When the bridge is in balance condition the voltage across the arm bc and ec are equal

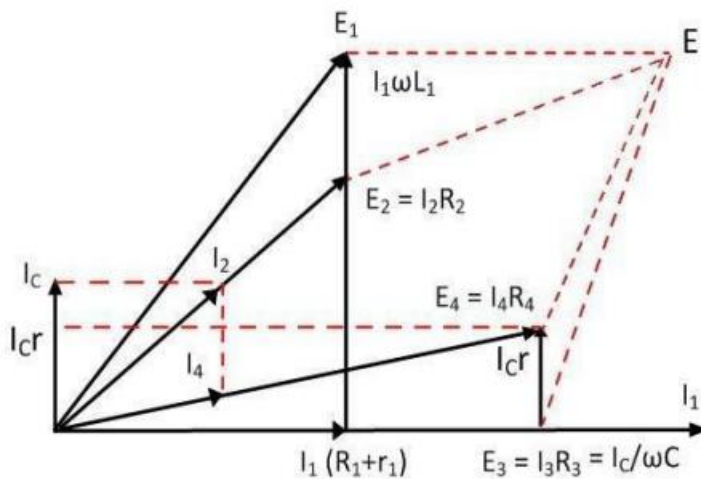

Advantages of Anderson's Bridge:

- 1) In Anderson's bridge it is very easy to obtain the balance point as compared to Maxwell's bridge.
- 2) In this bridge a fixed standard capacitor is used therefore there is no need of costly variable capacitor.
- 3) This method is very accurate for measurement of capacitance in terms of inductance.

Disadvantages:

- 1) Bridge is more complex
- 2) Difficult to attain balancing condition.

DeSauty Bridge:

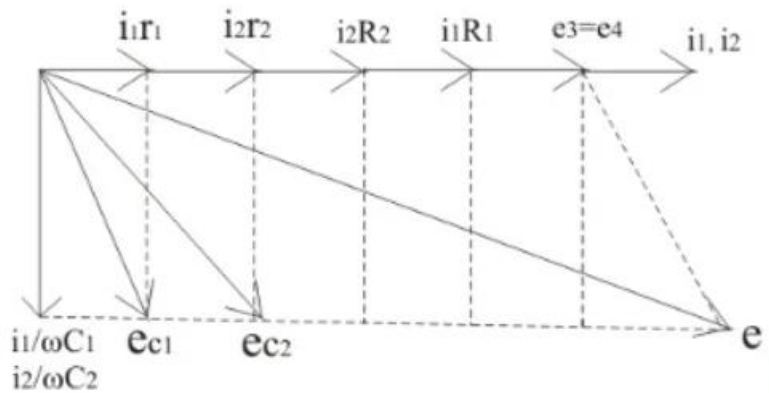
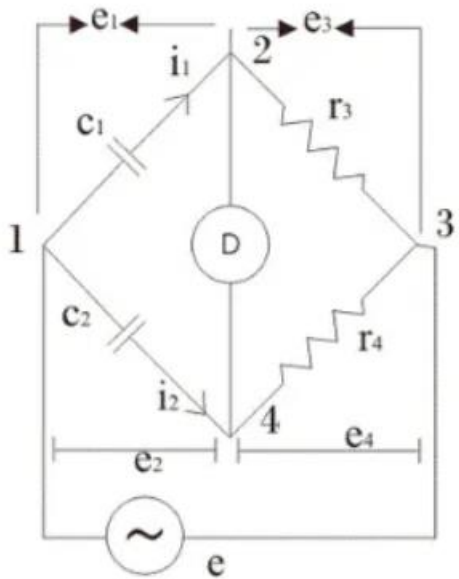

This bridge provides us the most suitable method for comparing the two values of capacitor if we neglect dielectric losses in the bridge circuit. The circuit of De Sauty's bridge is shown below.

Battery is applied between terminals marked as 1 and 4. The arm 1-2 consists of capacitor c_1 (whose value is unknown) which carries current i_1 as shown, arm 2-4 consists of pure resistor (here pure resistor means we assume it non inductive in nature), arm 3-4 also consists of pure resistor and arm 4-1 consists of standard capacitor whose value is already known to us.

Let us derive the expression for capacitor c_1 in terms of standard capacitor and resistors.

At balance condition we have,

$$\frac{1}{j\omega c_1} \times r_4 = \frac{1}{j\omega c_2} \times r_3$$

It implies that the value of capacitor is given by the expression

$$c_1 = c_2 \times \frac{r_4}{r_3}$$

In order to obtain the balance point we must adjust the values of either r_3 or r_4 without disturbing any other element of the bridge. This is the most efficient method of comparing the two values of capacitor if all the dielectric losses are neglected from the circuit.

Now let us draw and study the phasor diagram of this bridge. Phasor diagram of De Sauty bridge is shown below:

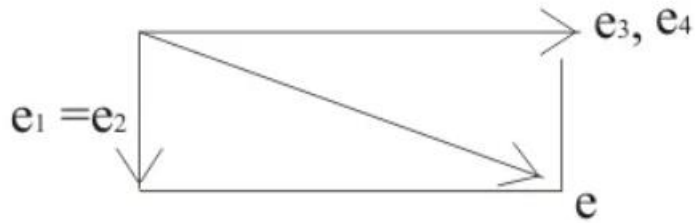

Phasor diagram

Let us mark the current drop across unknown capacitor as e_1 , voltage drop across the resistor r_3 be e_3 , voltage drop across arm 3-4 be e_4 and voltage drop across arm 4-1 be e_2 . At balance condition the current flows through 2-4 path will be zero and also voltage drops e_1 and e_3 be equal to voltage drops e_2 and e_4 respectively.

In order to draw the phasor diagram we have taken e_3 (or e_4) reference axis, e_1 and e_2 are shown at right angle to e_1 (or e_2). Why they are at right angle to each other? Answer to this question is very simple as capacitor is connected there, therefore phase difference angle obtained is 90° .

Now instead of some advantages like bridge is quite simple and provides easy calculations, there are some disadvantages of this bridge because this bridge give inaccurate results for imperfect capacitor (here imperfect means capacitors which not free from dielectric losses). Hence we can use this bridge only for comparing perfect capacitors.

Here we interested in modify the De Sauty's bridge, we want to have such a kind of bridge that will gives us accurate results for imperfect capacitors also. This modification is done by Grover. The modified circuit diagram is shown below:

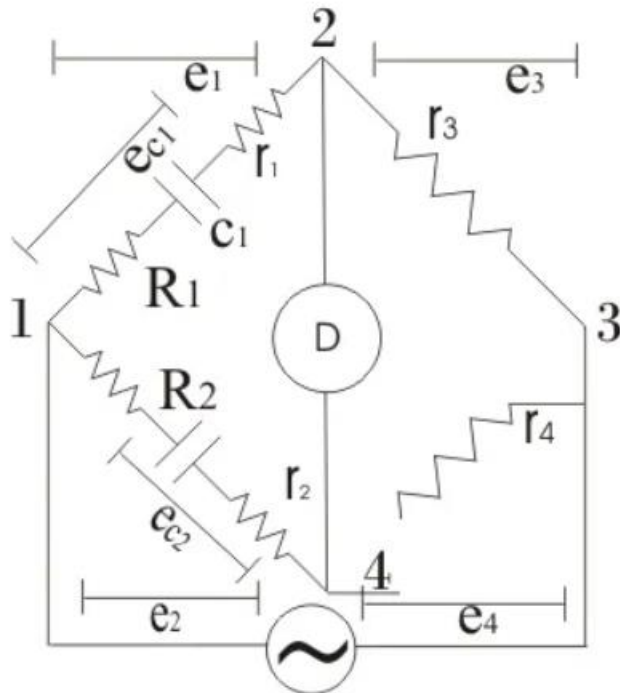

Here Grover has introduced electrical resistances r_1 and r_2 as shown in above on arms 1-2 and 4-1 respectively, in order to include the dielectric losses. Also he has connected resistances R_1 and

R2 respectively in the arms 1-2 and 4-1. Let us derive the expression capacitor c1 whose value is unknown to us. Again we connected standard capacitor on the same arm 1-4 as we have done in De Sauty's bridge. At balance point on equating the voltage drops we have:

$$\left(R_1 + r_1 + \frac{1}{j\omega c_1} \right) r_4 = \left(R_2 + r_2 + \frac{1}{j\omega c_2} \right) r_3 \dots \dots \dots (1)$$

On solving above equation we get:

$$\frac{c_1}{c_2} = \frac{R_2 + r_2}{R_1 + r_1} = r_4 r_3$$

This the required equation.

By making the phasor diagram we can calculate dissipation factor. Phasor diagram for the above circuit is shown below

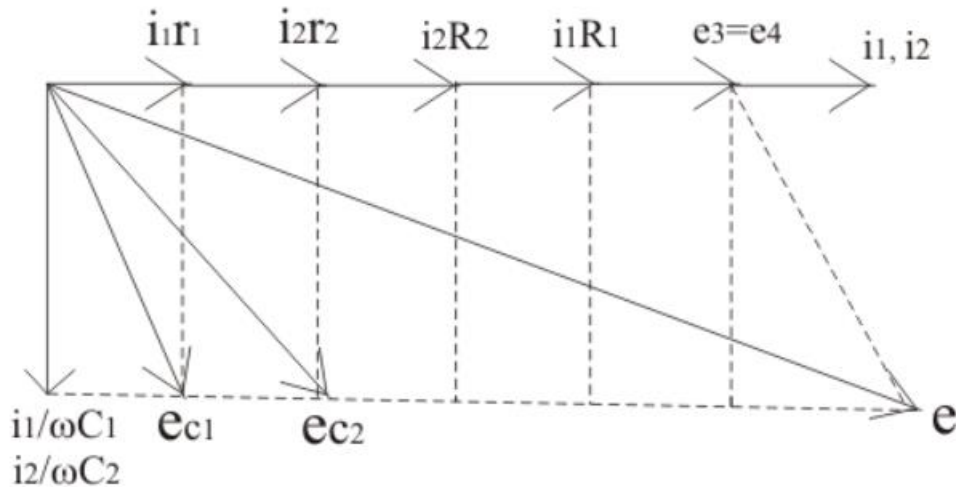

Let us mark δ_1 and δ_2 be phase angles of the capacitors c1 and c2 capacitors respectively. From the phasor diagram we have $\tan(\delta_1) = \text{dissipation factor} = \omega c_1 r_1$ and similarly we have $\tan(\delta_2) = \omega c_2 r_2$.

From equation (1) we have

$$c_2 r_2 - c_1 r_1 = c_1 R_1 - c_2 R_2$$

on multiplying ω both sides we have

$$\omega c_2 r_2 - \omega c_1 r_1 = \omega(c_1 R_1 - c_2 R_2)$$

But $\frac{c_1}{c_2} = \frac{r_4}{r_3}$

Therefore the final expression for the dissipation factor is written as

$$\tan(\delta_1) - \tan(\delta_2) = \omega c_2 \left(R_1 \frac{r_4}{r_3} - R_2 \right)$$

Hence if dissipation factor for one capacitor is known. However this method is gives quite inaccurate results for dissipation factor.

Wien's Bridge

The Wien's bridge use in AC circuits for determining the value of unknown frequency. The bridge measures the frequencies from 100Hz to 100kHz. The accuracy of the bridges lies between 0.1 to 0.5 percent. The bridge is used for various other applications like capacitance measurement, harmonic distortion analyser and in the HF frequency oscillator.

The Wien's bridge is frequency sensitive. Thereby, it is difficult to obtain the balance point in it. The input supply voltage is not purely sinusoidal, and they have some harmonics. The harmonics of the supply voltage disturbs the balance condition of the bridge. To overcome this problem the filter is used in the bridge. The filter connects in series with the null detector.

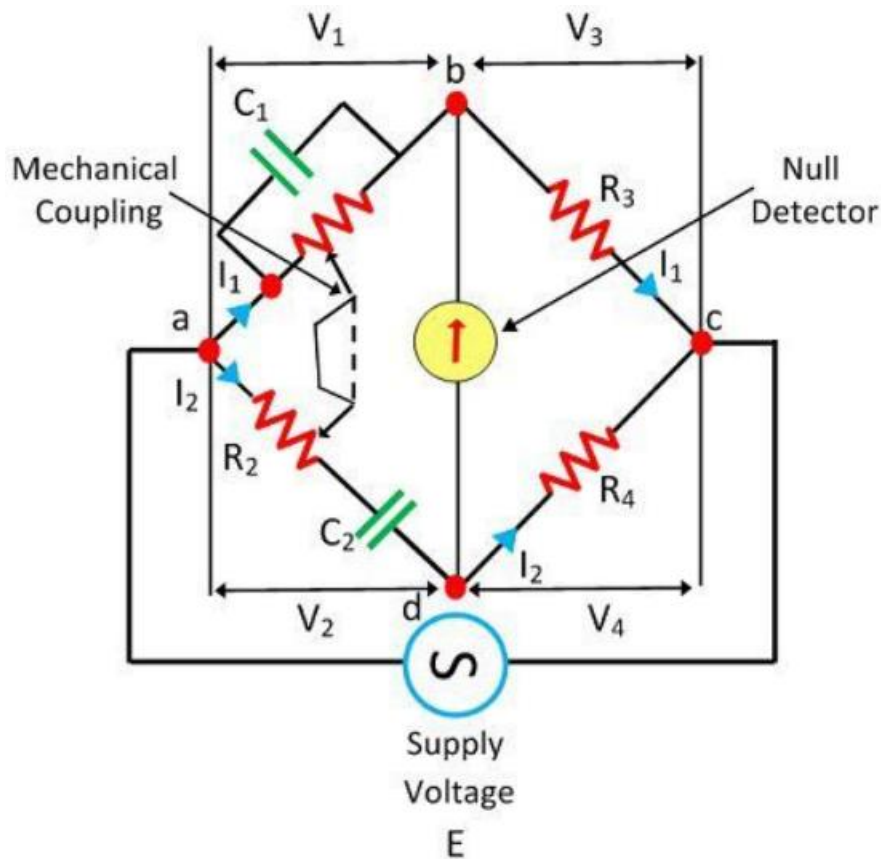

Wien's Bridge

Circuit Globe

When the bridge is in the balanced condition, the potential of the node B and C are equal, i.e., the $V_1 = V_2$ and $V_3 = V_4$. The phase and the magnitude of $V_3 = I_1 R_3$ and $V_4 = I_2 R_4$ are equal, and they are overlapping each other. The current I_1 flowing through the arm BD and the current I_2 flowing through R_4 is also in phase along with the $I_1 R_3$ and $I_2 R_4$.

The total voltage drop across the arm AC is equal to the sum of the voltage drop I_2R_2 across the resistance R_2 and the capacitive drop $I_2/\omega C_2$ across the capacitance C_2 . When the bridge is in a balanced condition, the voltage V_1 and V_2 both are equals in magnitude and phase.

The phase of the voltage V_1 and the voltage drop I_2R_2 across the arms R_2 is also same. The resistance R_2 is in the same phase as that of the voltage V_1 . The phasor sum of V_1 and V_3 or V_2 and V_4 will give the resultant supply voltage.

At balance condition, Wien's-bridge-equation-6

$$\left(\frac{R_1}{1 + j\omega C_1 R_1}\right)R_4 = \left(R_2 - \frac{j}{\omega C_2}\right)R_3$$

On equating the real part,

$$R_1 R_4 C_2 = R_2 C_2 R_3 + R_3 C_1 R_1$$

$$\frac{R_1 R_4 C_2}{R_1 R_3 C_2} = \frac{R_2 C_2 R_3}{R_1 R_3 C_2} + \frac{R_3 C_1 R_1}{R_1 R_3 C_2}$$

$$\frac{R_4}{R_3} = \frac{R_2}{R_1} + \frac{C_1}{C_2}$$

On comparing the imaginary part,

$$R_3 R_2 \omega^2 C_2 C_1 R_1 = R_3$$

$$R_2 \omega^2 C_2 C_1 R_1 = 1$$

$$\omega = \frac{1}{\sqrt{R_1 R_2 C_1 C_2}}$$

By substituting the value of $\omega = 2\pi f$,

$$f = \frac{1}{2\pi\sqrt{R_1 R_2 C_1 C_2}}$$

The slider of the resistance R_1 and R_2 mechanically connect to each other. So that, the $R_1 = R_2$ obtains.

Schering Bridge

The Schering bridge use for measuring the capacitance of the capacitor, dissipation factor, properties of an insulator, capacitor bushing, insulating oil and other insulating materials. It is one of the most commonly used AC bridge. The Schering bridge works on the principle of balancing the load on its arm.

Let, C_1 – capacitor whose capacitance is to be determined,

r_1 – a series resistance, representing the loss of the capacitor C_1 .

C_2 – a standard capacitor (The term standard capacitor means the capacitor is free from loss)

R_3 – a non-inductive resistance

C_4 – a variable capacitor.

R_4 – a variable non-inductive resistance parallel with variable capacitor C_4 .

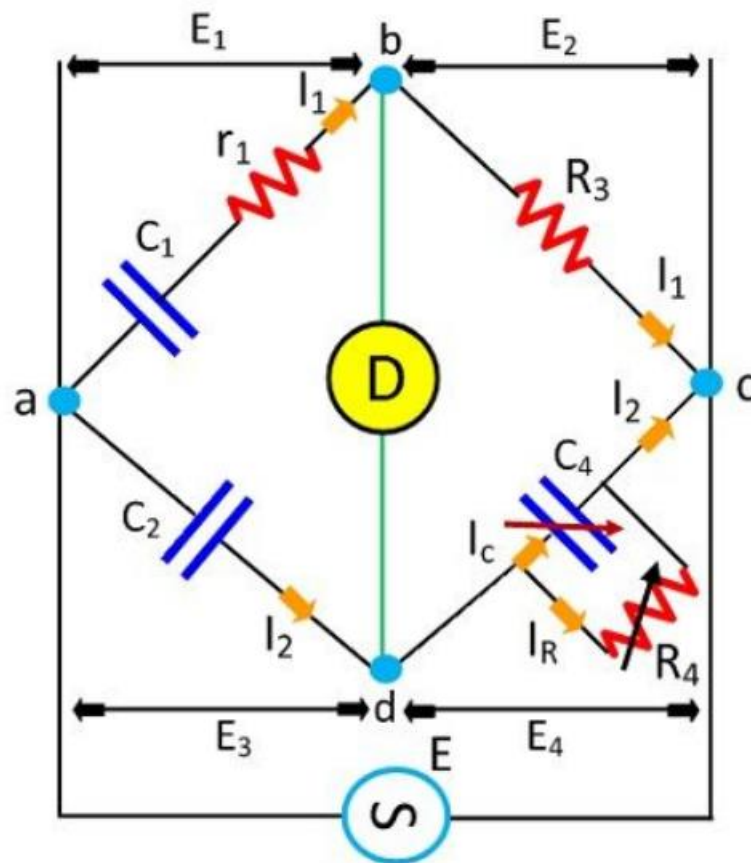

Low Voltage Schering Bridge

Circuit Globe

When the bridge is in the balanced condition, zero current passes through the detector, which shows that the potential across the detector is zero. At balance condition

$$Z_1/Z_2 = Z_3/Z_4$$

$$Z_1Z_4 = Z_2Z_3$$

So,

$$\left(r_1 + \frac{1}{j\omega C_1}\right) \left(\frac{R_4}{1 + j\omega C_4 R_4}\right) = \frac{1}{j\omega C_2} \cdot R_3$$

$$\left(r_1 + \frac{1}{j\omega C_1}\right) R_4 = \frac{R_3}{j\omega C_2} (1 + j\omega C_4 R_4)$$

$$r_1 R_4 - \frac{jR_4}{\omega C_1} = -j \frac{R_3}{\omega C_2} + \frac{R_3 R_4 C_4}{C_2}$$

Equating the real and imaginary equations, we get

$$r_1 = \frac{R_3 C_4}{C_2} \dots \dots \dots equ(1)$$

$$C_1 = C_2 \left(\frac{R_4}{R_3}\right) \dots \dots \dots equ(2)$$

The equation (1) and (2) are the balanced equation, and it is free from the frequency.

The dissipation factor obtains with the help of the phasor diagram. The dissipation factor determines the rate of loss of energy that occurs because of the oscillations of the electrical and mechanical instrument.

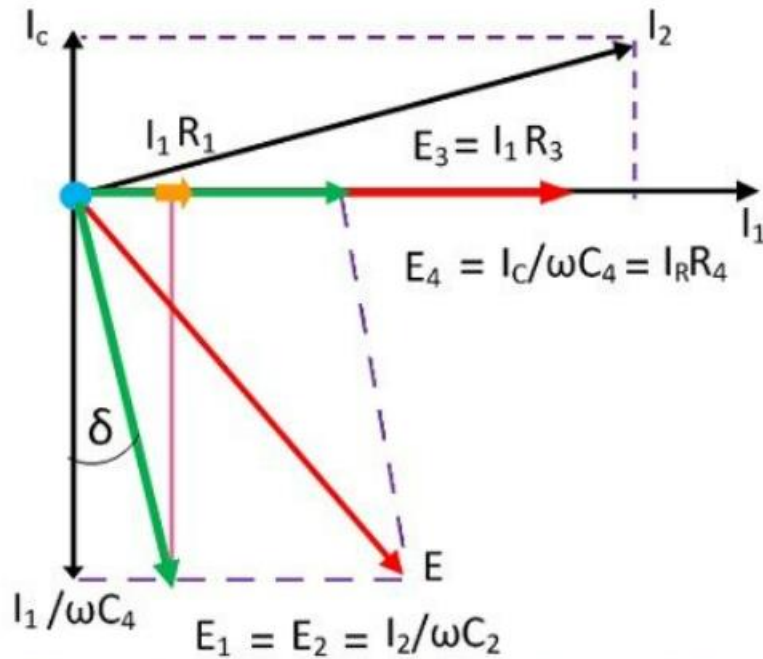

Phasor Diagram of Low Voltage Schering Bridge

Circuit Globe

$$D_1 = \tan \delta = \omega C_1 r_1 = \omega (C_1 r_1) = \omega (C_2 R_4 / R_3) \times (R_3 C_4 / C_2)$$

$$D_1 = \omega C_4 R_4$$

By the help of the above equation, we can calculate the value of $\tan \delta$ which is the dissipation factor of the Schering bridge.

Advantages of Schering Bridge

The following are the advantages of the Schering bridge.

- Balance equations are free from frequency.
- The arrangement of the bridge is less costly as compared to the other bridges.

UNIT-V: CRO AND DIGITAL METERS

Cathode Ray Oscilloscope

The CRO stands for a cathode ray oscilloscope. It is typically divided into four sections which are display, vertical controllers, horizontal controllers, and Triggers. Most of the oscilloscopes are used the probes and they are used for the input of any instrument. We can analyze the waveform by plotting amplitude along with the x-axis and y-axis. The applications of CRO are mainly involved in the radio, TV receivers, also in laboratory work involving research and design. In modern electronics, the CRO plays an important role in the electronic circuits.

What is a CRO?

The cathode ray oscilloscope is an electronic test instrument, it is used to obtain waveforms when the different input signals are given. In the early days, it is called as an Oscillograph. The oscilloscope observes the changes in the electrical signals over time, thus the voltage and time describe a shape and it is continuously graphed beside a scale. By seeing the waveform, we can analyze some properties like amplitude, frequency, rise time, distortion, time interval, and etc.

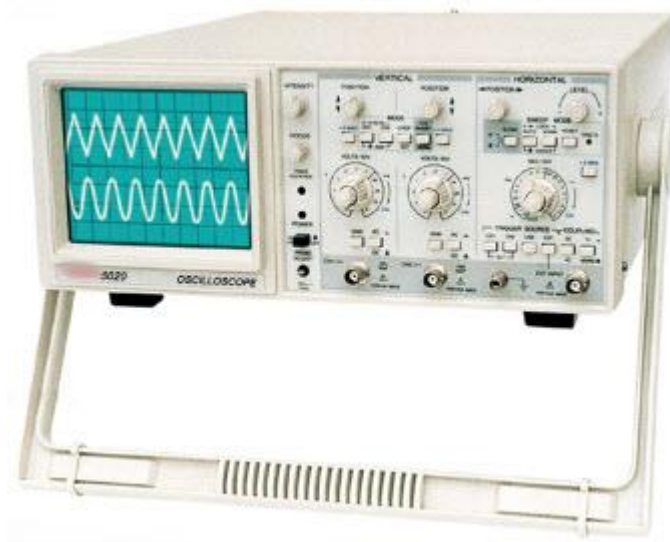

Block Diagram of CRO

The following block diagram shows the general-purpose CRO contraction. The CRO recruits the cathode ray tube and acts as a heat of the oscilloscope. In an oscilloscope, the CRT produces the electron beam which is accelerated to a high velocity and brings to the focal point on a fluorescent screen.

Thus, the screen produces a visible spot where the electron beam strikes with it. By detecting the beam above the screen in reply to the electrical signal, the electrons can act as an electrical pencil of light which produces a light where it strikes.

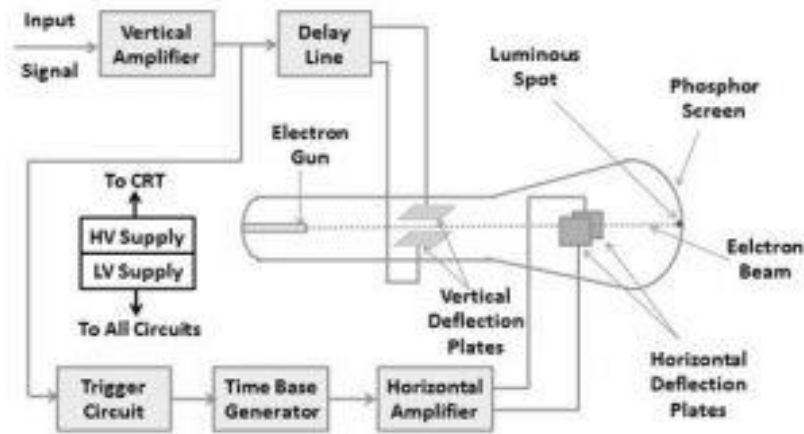

To complete this task we need various electrical signals and voltages. This provides the power supply circuit of the oscilloscope. Here we will use high voltage and low voltage. The low voltage is used for the heater of the electron gun to generate the electron beam. A high voltage is required for the cathode ray tube to speed up the beam. The normal voltage supply is necessary for other control units of the oscilloscope.

The horizontal and vertical plates are placed between the electron gun and the screen, thus it can detect the beam according to the input signal. Just before detecting the electron beam on the screen in the horizontal direction which is in X-axis a constant time-dependent rate, a time base generator is given by the oscillator. The signals are passed from the vertical deflection plate through the vertical amplifier. Thus, it can amplify the signal to a level that will be provided the deflection of the electron beam.

If the electron beam is detected in the X-axis and the Y-axis a trigger circuit is given for synchronizing these two types of detections. Hence the horizontal deflection starts at the same point as the input signal.

Working Principle

The CRO working principle depends on the electron ray movement because of the electrostatic force. Once an electron ray hits a phosphor face, then it makes a bright spot on it. A Cathode Ray Oscilloscope applies the electrostatic energy on the electron ray from two vertical ways. The spot on the phosphor monitor turns due to the effect of these two electrostatic forces which are mutually perpendicular. It moves to make the necessary waveform of the input signal.

Cathode Ray Tube:

The CRO is the vacuum tube and the main function of this device is to change the signal from electrical to visual. This tube includes the electron gun as well as the electrostatic deflection plates. The main function of this electron gun is used to generate a focused electronic ray that speeds up to high frequency.

The vertical deflection plate will turn the ray up & down whereas the horizontal ray moved the electrons beams from the left side to the right side. These actions are autonomous from each other and thus the ray may be located anyplace on the monitor.

Working of CRO

The following circuit diagram shows the basic circuit of a cathode ray oscilloscope. In this, we will discuss important parts of the oscilloscope.

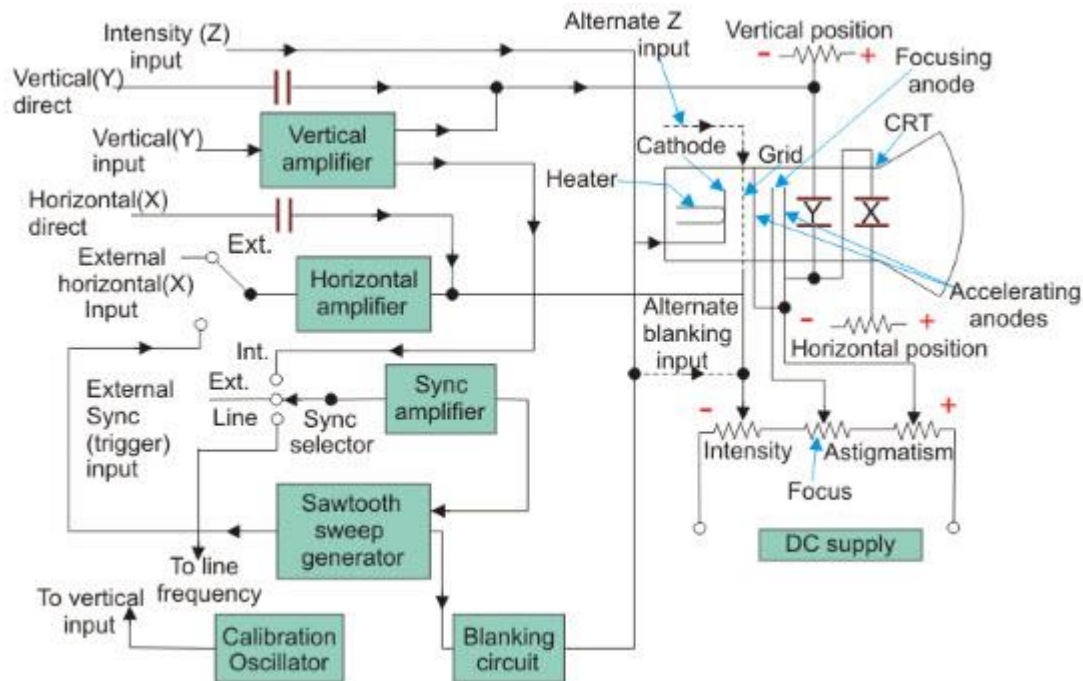

Vertical Deflection System

The main function of this amplifier is to amplify the weak signal so that the amplified signal can produce the desired signal. To examine the input signals are penetrated to the vertical deflection plates through the input attenuator and the number of amplifier stages.

Horizontal Deflection System

The vertical and horizontal system consists of horizontal amplifiers to amplify the weak input signals, but it is different from the vertical deflection system. The horizontal deflection plates are penetrated by a sweep voltage that gives a time base. By seeing the circuit diagram the sawtooth sweep generator is triggered by the synchronizing amplifier while the sweep selector switches in the internal position. So the trigger saw tooth generator gives the input to the horizontal amplifier by following the mechanism. Here we will discuss the four types of sweeps.

Recurrent Sweep

As the name, itself says that the sawtooth is respective that is a new sweep is started immediately at the end of the previous sweep.

Triggered Sweep

Sometimes the waveform should be observed that it may not be predicted thus, the desired that the sweep circuit remains inoperative and the sweep should be initiated by the waveform under the examination. In these cases, we will use the triggered sweep.

Driven Sweep

In general, the drive sweep is used when the sweep is free-running but it is triggered by the signal under the test.

Non-Saw Tooth Sweep

This sweep is used to find the difference between the two voltages. By using the non-sawtooth sweep we can compare the frequency of the input voltages.

Synchronization

The synchronization is done to produce a stationary pattern. The synchronization is between the sweep and the signal should measure. There are some sources of synchronization that can be selected by the synchronization selector. Which are discussed below.

Internal

In this, the signal is measured by the vertical amplifier and the trigger is obtained by the signal.

External

In the external trigger, the external trigger should be present.

Line

The line trigger is produced by the power supply.

Intensity Modulation

This modulation is produced by inserting the signal between the ground and cathode. This modulation causes by brightening the display.

Positioning Control

By applying the small independent internal direct voltage source to the detecting plates through the potentiometer the position can be controlled and also we can control the position of the signal.

Intensity Control

The intensity has a difference by changing the grid potential with respect to the cathode.

Electrical Quantities Measurements

Electrical quantities measurements by using CRO can be done like amplitude, time period and frequency.

- Measurement of Amplitude
- Measurement of Time Period
- Measurement of Frequency

Applications

- The CRO's are used in huge applications like radio stations for observing the transmitting & receiving the properties of the signal.

- The CRO is used to measure the voltage, current, frequency, inductance, admittance, resistance, and power factor.
- This device is also used to check the AM and FM circuits characteristics
- This device is used to monitor the signal properties as well as characteristics and also controls the analog signals.
- The CRO is used through the resonance circuit to view the shape of the signal, bandwidth, etc.
- The shape of voltage and current waveform can be observed by CRO which helps to take the necessary decision in a radio station or communication station.
- It is used in laboratories for the purpose of research. Once researchers design a new circuit, then they use CRO to verify the waveforms of voltage and current of every element of the circuit.
- Used for comparing phase & frequency
- It is used in TV, Radar, and analysis of engine pressure
- To check the reactions of nervous and heartbeat.
- In the hysteresis loop, it is used to find BH curves
- Transistor curves can be traced.

Measurement of Frequency

On the CRO screen, the measurement of time & frequency can be done very simply through the horizontal scale. If you want to make sure accuracy while measuring a frequency, then it assists to enhance the area of the signal on your CRO display so that we can more simply convert the waveform.

Initially, the time can be measured with the help of the horizontal scale on the CRO & counting the number of flat partitions from one finish of the signal to the other wherever it crosses the flat line. After that, we can develop the number of flat partitions through the time or division to discover the time period of the signal. Mathematically the measurement of the frequency can be signified as frequency = 1/period.

$$f = 1/T$$

Inductive sensor:

An inductive proximity switch is a sensor that is used in order to detect metal objects. The sensor does this in a way that is insusceptible to shape or color of the object. An important property of inductive sensors is that these are cheap and reliable .

Inductive sensors work on the principle of change of inductance. What exactly is this? The sensor generates an electromagnetic field with the help of the electromagnetic coil located in the head of the sensor. In operation, this means that when a metal object comes close to an inductive sensor, the so-called impedance in the coil changes. The change of this impedance depends on the distance between the metal object and the sensor.

An important advantage of inductive sensors is that they are insensitive to non-conductive materials such as plastic, rubber and stone. In addition, the sensors are therefore not susceptible to external environmental factors such as accumulations of dust and dirt that can cover the sensor head or the exposure to (sun) light that can cause false detection with other sensors.



The most commonly used inductive sensor has a round construction, M18 housing with M12 connector and a switching distance of 8 mm. Examples of this are:

- PNP-NO: IL8LI 1814E;
- PNP-NC: IL8LI 1815E;
- Budget version: PNP-NO: AK1/AP-3

The reduction factor

Warning! Inductive sensors have a so-called reduction factor. To understand what this means, it is necessary to come back to the way inductive sensors work; the difference in impedance in the coil allows the sensor to detect the metal object. However, not every type of metal conducts the energy of the electromagnetic field generated by the sensor equally well! That is why we work with a so-called reduction factor that differs per metal and sensor.

The reduction factor associated with a metal determines the sensor's performance and affects its effective measuring range. Ask one of our experts! Below is a table to indicate the reduction factor per metal type:

MATERIAL	REDUCTION FACTOR
Carbon steel	1.00
Stainless steel	0.85
Brass	0.50
Aluminum	0.45
Copper	0.40

Applications inductive sensors

To further explain the difference between inductive and capacitive sensors, here is more information about inductive sensors. As mentioned earlier, an inductive sensor, also known as a proximity switch, is a simple, reliable and inexpensive solution to determine a position or end position. Therefore there are countless application examples for this, such as:

- An elevator that arrives on a story floor;
- A conveyor belt that passes at a specific spot;
- Car wash installation, to determine the end and starting point;
- Overhead cranes, to determine the start or end point;
- As an encoder to detect metal strips, in order to determine position;

A short M18 sensor is often used for this, with a switching distance of 8 mm. Such as: AK1/AP-3H.

Capacitive sensor

Capacitive sensors can detect both metal and non-conductive materials. Think of viscose, but also aqueous liquids such as (petroleum) oil and water or all kinds of other solids, such as: plastics, stainless steel, brass, cardboard and animal materials such as leather. These are just a few of the many possible substances.

Detecting liquids or products can be used for the presence detection of grain in a feed silo, for example as a level measurement or full and empty detections. The shape and color of the object have no influence on the result. Examples of capacitive proximity switches are:

- Size: M18 - 8 mm detection distance: C18P/BP-1E
- Size: M30 - 25 mm detection distance: C30P/BP-2E
- Size: Cubic - 25 mm detection distance: CQ55/BP-3A

The way capacitive sensors work is almost the same as that of inductive sensors. The sensor "looks" by means of an active capacitive field (also called dielectric). When this field changes, the sensor will detect. The air is in many cases the constant, when an object comes close to the sensor, the capacitive field changes. The object that passes the sensor has a higher density than air, so the sensor switches.

Mounting of inductive and capacitive sensors

Both inductive and capacitive sensors have two types of mounting: flush and non-flush. The mounting method may differ depending on the sensor model. The way in which the sensors are mounted in the application has an influence on its detection range and the moment when an object is detected.

In a flush mounting, the sensor is mounted so that the sensor head runs flush with the mounting surface. In a non-flush mounting, the sensor head protrudes above the mounting surface. This has direct consequences in the detection: a sensor with a flush mounting will only detect objects that appear directly in front of the sensor head. The sensor with non-flush mounting is also

interrupted by objects that appear on the sides of the sensor head. This type of sensor can achieve a larger detection range.



Applications capacitive sensors

- Level monitoring of liquids
- Filling notification of bottles
- Non-metallic object detection on conveyor belt

Electromagnetism in sensing

Electromagnetic sensors, such as induction coils, hall sensors, giant magnetoresistance (GMR) sensors, anisotropic magnetoresistance (AMR) sensors, magnetoimpedance (MI) sensors, fluxgate sensors, optical magnetometers, atomic magnetometers, and superconducting quantum interference devices (SQUIDs), are being used in a wide range of fields including material evaluation, biomagnetism, geophysics, communication, automobile, and aerospace.

In recent years, the properties of magnetic sensors have been greatly improved. For example, the magnetic field resolutions of low-cost, solid-state, room-temperature magnetic sensors, such as fluxgate and MI sensors, have reached the order of picotesla level, which will inevitably lead to the wider application of magnetic field sensors.

This special issue aims to attract novel research articles in the fields of high sensitivity magnetic sensors and their applications, including the research on sensor materials, sensor devices, and the development of equipment and systems to facilitate them. Review articles on the recent progress or summaries of previous works are also welcome.

Potential topics include but are not limited to the following:

- Coils, coil arrays, and RF sensors
- MI sensors
- AMR sensor
- Tunnel magnetoresistance (TMR) sensors
- GMR sensors
- Fluxgate sensors

- Optical magnetometers
- Atomic magnetometers
- SQUIDs
- Nondestructive evaluation applications using magnetic sensors
- Biomedical sensing using magnetic sensors

Flow sensor:

A flow sensor (more commonly referred to as a “flow meter”) is an electronic device that measures or regulates the flow rate of liquids and gasses within pipes and tubes. Flow sensors are generally connected to gauges to render their measurements, but they can also be connected to computers and digital interfaces. They are commonly used in HVAC systems, medical devices, chemical factories, and septic systems. Flow sensors are able to detect leaks, blockages, pipe bursts, and changes in liquid concentration due to contamination or pollution.

Flow sensors can be divided into two groups: contact and non-contact flow sensors. Contact flow sensors are used in applications where the liquid or gas measured is not expected to become clogged in the pipe when it comes into contact with the sensor’s moving parts. In contrast, non-contact flow sensors have no moving parts, and they are generally used when the liquid or gas (generally a food product) being monitored would be otherwise contaminated or physically altered by coming into contact with moving parts.

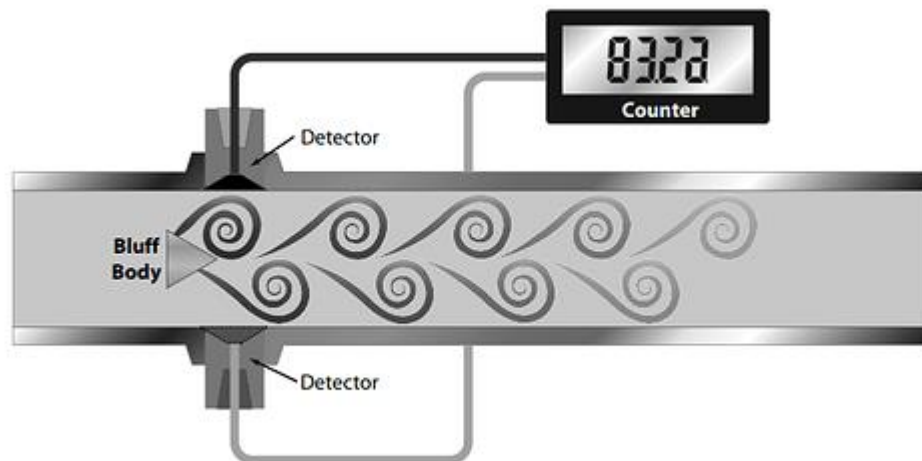

Fig: Vortex flow sensor

The two most common types of contact flow sensors are vortex and mechanical flow sensors. Vortex flow sensors are comprised of a small latch (known as the “buff body”) that flexes back and forward when coming into contact with a flowing liquid or gas. The differences in pressure (i.e. the vortices) generated by the latch are measured to determine the flow rate. Mechanical flow sensors use propellers that spin at a rate that is directly proportional to the flow rate. Mechanical flow sensors can also be controlled to cause the flow rate to increase or decrease.

Ultrasonic flow sensors are the most popular type of non-contact flow sensor. Ultrasonic flow sensors send pulses of high frequency sound across the flowing liquid or gas medium. These sensors measure the time between the emission of the sound and its contact with the sensor’s receiver to determine the flow rate of the gas or liquid.

Level Sensor

A level sensor is a device that is designed to monitor, maintain, and measure liquid (and sometimes solid) levels. Once the liquid level is detected, the sensor converts the perceived data into an electric signal. Level sensors are used primarily in the manufacturing and automotive industries, but they can be found in many household appliances as well, such as ice makers in refrigerators.

There are two main classifications for level sensors: point level sensors and continuous level sensors. Point level sensors are designed to indicate whether a liquid has reached a specific point in a container. Continuous level sensors, on the other hand, are used to render precise liquid level measurements. Level sensors can be divided further into invasive and non-contact sensors. Invasive sensors make direct contact with the substance they are measuring, while non-contact sensors use sound or microwaves.

There are many different types of point level sensors, but they are all invasive. One of the most basic point level sensors is the “float switch.” When a liquid level rises or falls in a container, it forces the switch to open or close a circuit. Optical level sensors are comprised of an infrared (IR) emitter and a photodiode. As photoelectric proximity sensors, they detect the presence of liquid by measuring the amount of infrared light that is reflected back into the photodiode. Capacitance level sensors measure change in capacitance (the ability to store electric charge) to determine liquid levels in tanks. “Tuning fork” sensors use differences in pressure and vibration to measure liquid level.

Unlike point level sensors, the two main types of continuous level sensors (ultrasonic and microwave) are non-contact. Ultrasonic level sensors emit sound waves, while “radar” sensors emit microwaves. The time interval between wave emission and reflection is directly proportional to the liquid level.

Position Sensor

The position sensor is a device that collects information on the precise position and movement of an object. The information can be obtained by direct contact with the object or remotely using magnetic sensors. It can also detect the thickness of a part, the level of a fluid or the angle of rotation of a shaft. The position sensor is essential for the correct operation of different machines such as machine tools

The position sensor can operate in different ways:

- It delivers a signal that varies according to the position of the object. It is through these signal variations that the displacement is translated.
- With each elementary movement, it emits an impulse. It is by counting the pulses emitted that the displacement and position are determined.
- It provides a signal through a field when there is no mechanical connection between it and the moving object. This may be an electromagnetic field as with Eddy-current sensors, an electrostatic field as with capacitive sensors and a magnetic induction field as with magneto-resistance, reluctance variation or hall effect sensors.

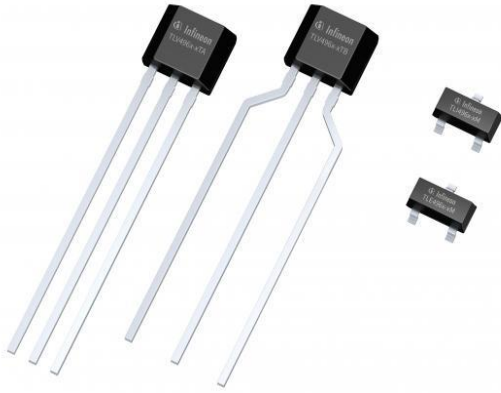

There are a wide variety of position sensors such as:

- The optical sensor based on the reception and emission of a light beam.
- The ultrasonic sensor which is equipped with a transmitter and a receiver. A wave train is reflected on the object to be detected and then returns to the source. The distance of the object is determined from the time it takes the wave stream to travel back and forth.
- The capacitive sensor allowing the detection of an object of any nature. When an object is in front of the sensitive face of the detector, it is reflected by a variation in the capacitive coupling. The oscillator is then triggered to start by this capacitance change. Following this, an output signal is delivered after formatting.
- The pneumatic sensor that allows non-contact detection of an object at a short distance.
- The mechanical sensor which is a contact sensor and allows to interrupt or establish an electrical contact by mechanical action on the moving part of the sensor.
- The inductive sensor (hall effect). Several types of sensors can coexist since they are all based on a magnetic phenomenon. Among these types of sensors is the hall effect sensor

MOTION SENSOR:

A motion sensor (or motion detector) is an electronic device that is designed to detect and measure movement. Motion sensors are used primarily in home and business security systems, but they can also be found in phones, paper towel dispensers, game consoles, and virtual reality systems. Unlike many other types of sensors (which can be handheld and isolated), motion sensors are typically embedded systems with three major components: a sensor unit, an embedded computer, and hardware (or the mechanical component). These three parts vary in size and configuration, as motion sensors can be customized to perform highly specific functions. For example, motion sensors can be used to activate floodlights, trigger audible alarms, activate switches, and even alert the police.

There are two types of motion sensors: active motion sensors and passive motion sensors. Active sensors have both a transmitter and a receiver. This type of sensor detects motion by measuring changes in the amount of sound or radiation reflecting back into the receiver. When an object interrupts or alters the sensor's field, an electric pulse is sent to the embedded computer, which in turn interacts with the mechanical component. The most common type of active motion detector uses ultrasonic sensor technology; these motion sensors emit sound waves to detect the presence of objects. There are also microwave sensors (which emit microwave radiation), and tomographic sensors (which transmit and receive radio waves).

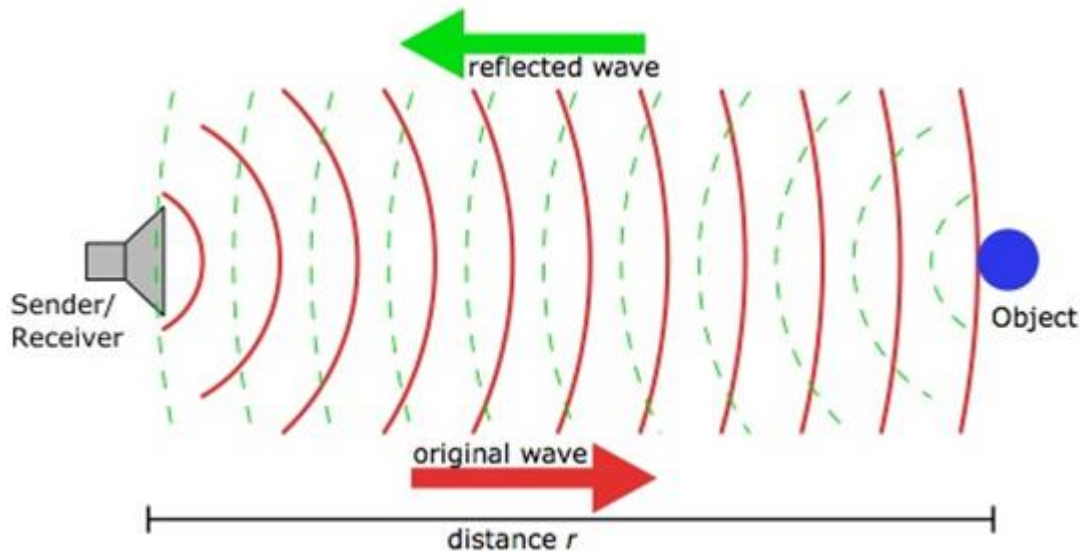

Unlike an active motion sensor, a passive motion sensor does not have a transmitter. Instead of measuring a constant reflection, the sensor detects motion based on a perceived increase of radiation in its environment. The most widely used type of passive motion sensor in home security systems is the passive infrared (PIR) sensor. The PIR sensor is designed to detect the infrared radiation emitted naturally from the human body. The receiver is contained in a filter that only allows infrared to pass through it. When a person walks into the PIR sensor's field of detection, the difference in radiation creates a positive charge within the receiver; this perceived change causes the sensing unit to send electrical data to the embedded computer and hardware component.

Pressure sensor:

A pressure sensor is an electronic device that detects, regulates, or monitors pressure, and converts perceived physical data into an electronic signal. Pressure is defined as the amount of force (exerted by a liquid or gas) applied to a unit of "area" ($P=F/A$), and the traditional unit of pressure is the Pascal (which is one Newton per square meter). Pressure sensors often utilize piezoelectric technology, as piezoelectric elements give off an electric charge proportional to the stress (brought on by pressure) they experience.

There are three main types of pressure sensors, and they each measure different types of pressure. Gauge pressure sensors measure relative to the ambient atmospheric pressure. This means that the readings are entirely dependent on the pressure of the air around the sensor. It is also affected by variables such as weather and altitude. When the gauge sensor experiences a pressure greater than atmospheric pressure, it is said to have a positive pressure. If the pressure is lower than atmospheric pressure, it is a negative pressure. Gauge pressure sensors are commonly used in liquid-level detection in a tank.

The second type, absolute pressure sensors, measure pressure in reference to absolute zero pressure (or a vacuum). This allows for extremely precise pressure measurements, as its readings are in reference to no pressure as opposed to a varying atmospheric pressure. Absolute pressure sensors are often used as altimeters and barometers to measure atmospheric pressure. They are also used for detecting leaks in sealed containers.

The third type of pressure sensor, differential sensors, use two different pressure ports and measure the difference in pressure in reference to each other. Differential pressure sensors are mainly used to detect differences in pressure in tubes and water mains and monitor filtration systems. Pressure sensors are also found in automobiles (to detect tire pressure or combustion

pressure in an engine, factories (to regulate steam or water in machinery), and aircraft (to determine altitude and atmospheric conditions)

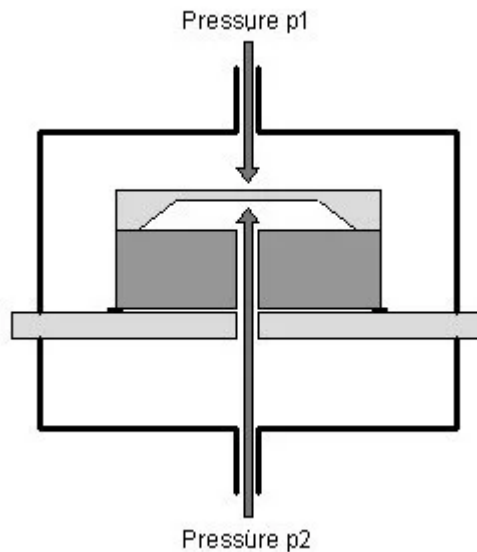

Temperature sensor:

A temperature sensor is an electronic device that measures the temperature of its environment and converts the input data into electronic data to record, monitor, or signal temperature changes. There are many different types of temperature sensors. Some temperature sensors require direct contact with the physical object that is being monitored (contact temperature sensors), while others indirectly measure the temperature of an object (non-contact temperature sensors).

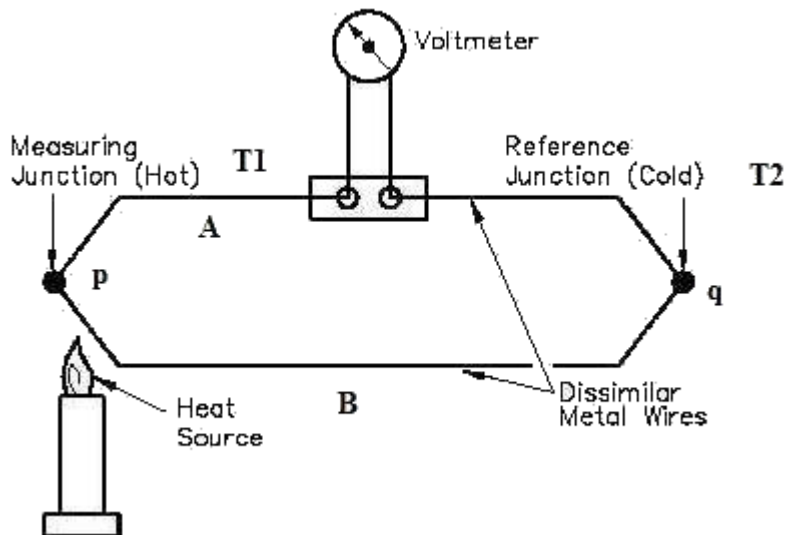

Non-contact temperature sensors are usually infrared (IR) sensors. They remotely detect the IR energy emitted by an object and send a signal to a calibrated electronic circuit that determines the object's temperature.

Among the contact temperature sensors are thermocouples and thermistors. A thermocouple is comprised of two conductors, each made of a different type of metal, that are joined at an end to form a junction. When the junction is exposed to heat, a voltage is generated that directly

corresponds to the temperature input. This happens on account of the phenomena called the thermoelectric effect. Thermocouples are generally inexpensive, as their design and materials are simple. The other type of contact temperature sensor is called a thermistor. In thermistors, resistance decreases as temperature increases. There are two main types of thermistors: Negative Temperature Coefficient (NTC) and Positive Temperature Coefficient (PTC). Thermistors are more precise than thermocouples (capable of measuring within 0.05-1.5 degrees Celsius), and they are made of ceramics or polymers. Resistance Temperature Detectors (RTD) are essentially the metal counterpart of thermistors, and they are the most precise and expensive type of temperature sensors.

Temperature sensors are used in automobiles, medical devices, computers, cooking appliances, and other types of machinery.