

MATERIAL SCIENCE & ENGINEERING (20A03201T)

LECTURE NOTES

I-B.TECH & II-SEM

Prepared by:

Mr. P. KUMAR, Assistant Professor

Department of Mechanical Engineering



VEMU INSTITUTE OF TECHNOLOGY

(Approved By AICTE, New Delhi and Affiliated to JNTUA, Ananthapuramu)

Accredited By NAAC, NBA(EEE, ECE & CSE) & ISO: 9001-2015 Certified Institution

Near Pakala, P.Kothakota, Chittoor- Tirupathi Highway

Chittoor, Andhra Pradesh-517 112

Web Site: www.vemu.org



Mechanical Engineering

Course Code	MATERIAL SCIENCE & ENGINEERING	L	T	P	C
20A03201T		3	0	0	3
Pre-requisite	MATERIAL SCIENCE & ENGINEERING	Semester			II

Course Objectives:

- To teach the principles of physical metallurgy, i.e. crystallography of metals, constitution of alloys, phase diagrams.
- Expose commercially important metals and alloys (both ferrous and non ferrous) with engineering constraints.
- Explain the methods to change the properties of materials through heat treatment processes
- Familiarize properties and applications of ceramics, polymers and composite materials.
- Demonstrate the fundamental properties of nano-materials and their applications.

Course Outcomes (CO):

 After completion of the course, the student can able to

CO-1: Apply the philosophy of metals and alloys, Interpretation of binary phase diagrams and Iron-Iron-carbide diagram and microstructural aspects of ferrite, cementite, austenite, ledeburite and cast iron.

CO-2: Analyze various types of Steels and Cast iron, Micro structure, properties and applications of steels and cast iron.

CO-3: Evaluate Heat treatment of steels based on their cooling effects, Discriminate their microstructure, properties and applications of various processes.

CO-4: Identify and apply various Ferrous, Non-ferrous metals and alloys to generate different microstructure, properties and applications of copper, aluminium, titanium, nickel and their alloys.

CO-5: To examine ceramics, polymers and composites and compare its structure, properties and applications.

Unit – I: Structure of metals & constitution of alloys

Structure of Metals: Crystal Structures: Unit cells, Metallic crystal structures, Imperfection in solids: Point, Line, interstitial and volume defects; dislocation strengthening mechanisms and slip systems, critically resolved shear stress.

Constitution of Alloys: Necessity of Alloying, substitutional and interstitial solid solutions- Phase diagrams: Interpretation of binary phase diagrams and microstructure development; eutectic, peritectic, peritectoid and monotectic reactions. Iron-Iron-carbide diagram and microstructural aspects of ferrite, cementite, austenite, ledeburite, and cast iron.

Unit – II: Steels and Cast irons

Steels: Plain carbon steels, use and limitations of plain carbon steels. AISI& BIS classification of steels. Classification of alloy steels. Microstructure, properties and applications of alloy steels-stainless steels and tool steels.

Cast irons: Microstructure, properties and applications of white cast iron, malleable cast iron, grey cast iron, nodular cast iron and alloy cast irons.

Unit – III: Heat Treatment of Steels

Heat Treatment of Steels: Annealing, tempering, normalizing and hardening, isothermal transformation diagrams for Fe-Fe₃C alloys and microstructure development. Continuous cooling curves and interpretation of final microstructures and properties- austempering, martempering, case hardening - carburizing, nitriding, cyaniding, carbo-nitriding, flame and induction hardening, and vacuum and plasma hardening

Unit – IV: Non-ferrous Metals and Alloys

Non-ferrous Metals and Alloys: Microstructure, properties and applications of copper, aluminium, titanium, nickel and their alloys. Study of Al-Cu phase diagram

Unit – V: Ceramics, Polymers and Composites

Ceramics, Polymers and Composites: Structure, properties and applications of ceramics, polymers and composites. Introduction to super alloys and nanomaterials.

Textbooks:

1. V.Raghavan, Material Science and Engineering, 5/e, Prentice Hall of India, 2004.
2. R.Balasubramaniam, Callister's Material Science and Engineering, 2/e, Wiley India, 2014.

Reference Books:

1. Y. Lakhtin, Engineering Physical Metallurgy, University Press of the Pacific, 2000.
2. S.H.Avner, Introduction to Physical Metallurgy, 2/e, Tata McGraw- Hill, 1997.
3. L.H.Van Vlack, Elements of Material Science and Engineering, 6/e, Pearson Education, 2008.
4. George E.Dieter, Mechanical Metallurgy, 3/e, McGraw-Hill, 2013.

UNIT-I

Structure of Metals & Constitution of Alloys

Lecture notes

STRUCTURE OF METALS & ITS ALLOYS:**BONDING IN SOLIDS:**

When the atoms of the elements combines to form molecules a force of attraction is developed between the atoms, which holds them together this force is known as “**Bond**”.

Atoms are held together in solids by electrostatic forces of attraction.

An electric force of attraction occurs between positively and negatively charged particles, and there are various ways in which such electric forces can be produced between atoms in solids.

Causes of Bonding:

The atoms or molecules forms bonds with another, in order to achieve stable configuration in the following 3 ways

- By loosing one or more electrons to another atom
- By gaining one or more electrons from another atom
- By sharing one or more electrons with another atom

Classification of Bonds :

- According to the nature of forces of attraction bonds are classified as
 - Primary bonding
 - Secondary bonding
- **Primary bonds:**
 - Primary bonds are inter atomic bonds in which electro static force holds the atoms together.
 - They are more stable and relatively strong bonds.
 - Examples- metallic, ionic and covalent bonds
- **Secondary bonds:**
 - Secondary bonds are inter molecular bonds in which the weak forces holds the molecules together
 - These weak forces are known as vanderwall’s force.
 - They are relatively weak.
 - Examples- dispersion bond, dipole bond and hydrogen bond.

Secondary bond is weak and less stable when compared to primary bond

Types of Primary Bond:

1. Ionic Bond
2. Covalent Bond
3. Metallic bond

1. Ionic Bond:

1. It is also known as electro valent bond
2. It is formed between atoms of metals and nonmetals
3. An ionic bond is formed when one or more electrons, from the outer most shell of one atom, are transferred to the outermost shell of another atom
4. The electro static attraction b/w the oppositely charged ions forms the ionic bond
5. Following are the two conditions are necessary for the bond formation :
 1. The atom which loses the electron should have low ionization energy. It means that a small amount of energy is required to remove the electron from its outermost energy level
 2. The atom which gains the electron should have high electron affinity. It means that the atom should be able to readily accept an electron from its outermost energy level

Ex: formation of ionic bond in sodium chloride (NaCl)

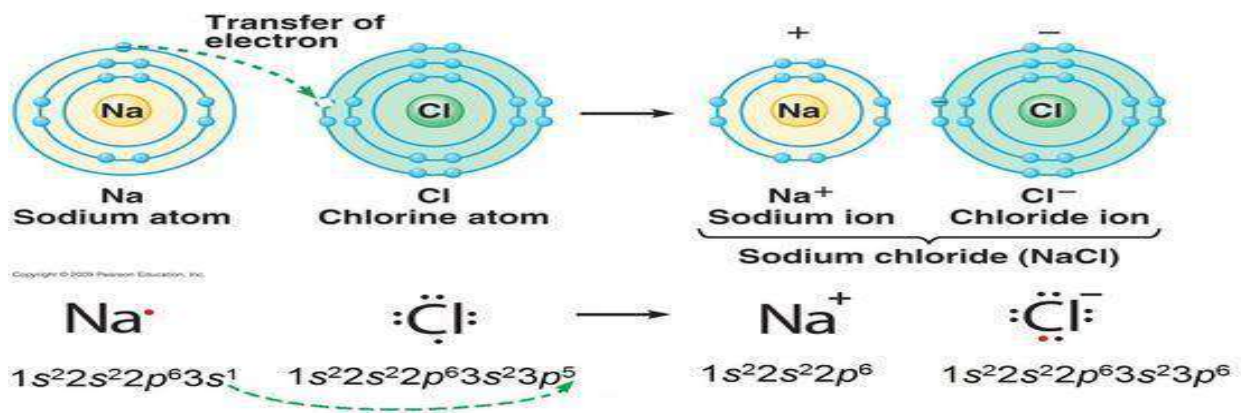

- The atomic no of Na is 11 and Cl is 17 .the atomic structure of both Na and Cl atoms are shown in fig. Thus we see that the Na atom has 1electron in its outer most energy level and Cl atom has 7 electrons in its outer most energy level
- The Na atom has tendency to lose its electron in its outermost energy level to have a stable configuration. more over the Cl atom has a tendency to accept one electron (lost by Na atom) in its outer most energy level to have a stable electronic configuration of argon

Properties of ionic solids:

1. Ionic solids are rigid, uni directional and crystal in nature
2. The ionic solids have very low electrical and thermal conductivities
3. The ionic solids have high hardness due to their crystalline structure
4. The ionic solids are not malleable and ductile
5. They have high melting and boiling temperature
6. They exist in the form of solids only
7. They are freely soluble in water but slightly soluble in organic solvents

Covalent bond:

- It exist due to the electrostatic force of attraction b/w atoms which share the electron pairs to form a covalent bond
- It is formed b/w similar or dissimilar atoms

Ex: O₂, CO₂, C₂H₆, H₂O, Sic

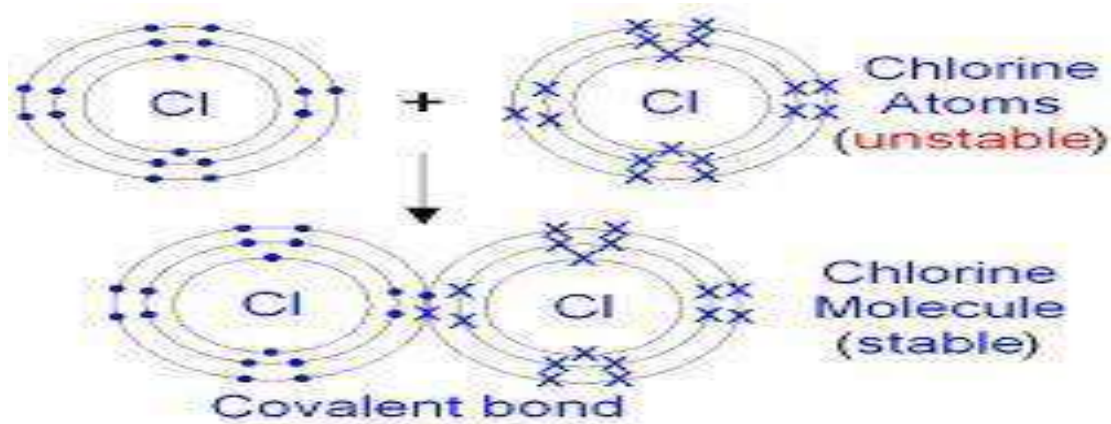

Fig: covalent bond formation of chorine molecule

In Cl molecule it consists of 7 electrons in its outer most shell. it need one more electron to achieve stable configuration Argon it share another chlorine atom as shown in fig

Note :

- When the atoms share one pair of electron the bond formed is single bond, two or three pair of electron, the bond formed is single or double or triple covalent bond

They are two types of covalent bands-

- Non Polar

- bonded atoms that share e⁻'s equally

- same atoms bonded

ex. Cl – Cl: Cl₂

- Polar
 - bonded atoms that do not share e^- 's equally
 - different atoms bonded

H

ex. H – N – H: NH_3

Properties of ionic solids:

- ✓ These are bad conductors of electricity
- ✓ These compounds are low melting & boiling temp
- ✓ These are not soluble in water ,but are soluble in organic components such as benzene, toluene etc

3. Metallic bond:

A bond formed by the attraction between electron cloud and positively charged ion (cation) of same or different metals

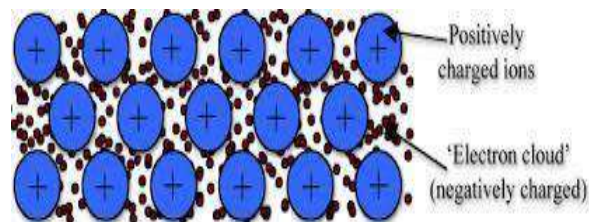

Fig: Metallic bond formation

Properties of metallic solids:

- ✓ These are high electrical and thermal conductivities
- ✓ Metallic solids have crystalline structure but are soft in nature
- ✓ These solids are low melting and boiling temperature than ionic solids
- ✓ These are exist in the form of solids only
- ✓ These are neither soluble in water nor organic solvents

2. Secondary Bond

1. Dispersion bond:

- This bond as shown in a symmetrical molecule.

- The electrons are uniformly distributed around the nucleus.
- But due to mutual repulsion, electrons disperse in asymmetrical manner the displacement of positive and negative charges, and forms a dipole (pair of two opposite and equal charges).
- These dipoles oscillate and influence each other resulting in a weak attraction force which forms the dispersion bond.
- Example- molecules of the inert gas are held by dispersion bond.

2. Dipole bond:

- Unequal sharing of electrons between the atoms results that the center of positive and negative charges does not coincide and the electrical dipole (molecule with one end positive and other end negative).
- These dipoles provide molecular attraction resulting in the formation of dipole bond.
- Dipole bonds are weaker than ionic bonds but stronger than dispersion bond.

Example- formation of hydrogen chloride (HCL).

In HCL, molecule region near the hydrogen nucleus is highly positive and opposite region near the chlorine nucleus is negative.

Attractive between the regions results dipole bond.

3. Hydrogen bond:

- Hydrogen bond results between hydrogen atom and any other electro-negative atoms such as oxygen and nitrogen.

Example-

In water molecules two H₂ ends of the molecule being slightly positive (i.e. from proton) relative to the oxygen atom (electron).

Each water molecule form a dipole.

Hydrogen bond occurs as a result of electro-static attraction between these molecule from a dipole.

BOND ENERGY OR BINDING ENERGY: It is defined as the energy to break the bond or to separate the atom is known as "**bond energy**"

➤ It is expressed in kj/mole

BOND LENGTH:

- The bond length may be defined as equilibrium separation (r) b/w the centre-to-centre of two bonding atoms.
- The force of attraction b/w the two bonding atoms, smaller will be the equilibrium separation and hence smaller the bond length.
- The primary bond are more stronger than the secondary bond, then the bond length of primary bond are smaller than those of secondary bonds
- The bond length of primary bond are in the range of 1-2 \AA , for secondary bonds of 2-5 \AA

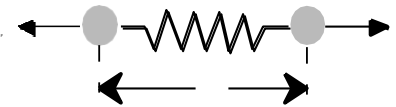
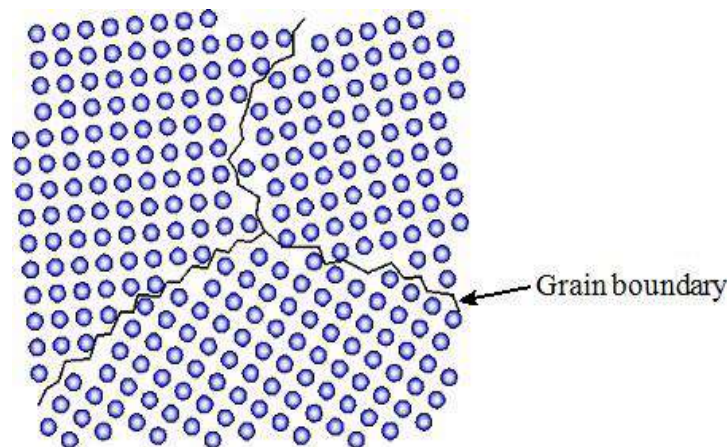

Fig: bond length

Crystallization of solids:

- **crystal** or **crystalline solid** is a solid material whose constituent atoms, molecules or ions etc are arranged in an ordered pattern extending in all three dimensions. which are acquired under the action of inter molecular forces.
- Crystals are also known as grains
- The boundary separating the two adjacent grains is called grain boundary
- The scientific study of crystals and crystal formation is known as "crystallography."
- The process of crystal formation via mechanisms of crystal growth is called "Crystallization or solidification."
- All materials are crystalline in nature.



- **Single Crystals:** Crystals can be *single crystals* where the whole solid is one crystal. Then it has a regular geometric structure with flat faces.

➤ **Polycrystalline Materials:**

- A solid can be composed of many crystalline grains, not aligned with each other. It is called **polycrystalline**.
- ❖ The grains can be more or less aligned with respect to each other. Where they meet is called a **grain boundary**.

❖ **Crystalline and Non-crystalline materials**

➤ **Crystalline Solids:-**

- ❖ In crystalline substances the atoms are arranged in regular pattern then it's called crystalline solids.
- ❖ the distance b/w any two successive atoms is equal
Example: Cu, Al, Fe etc

➤ **Non-Crystalline Solids or Amorphous solids :**

- ❖ The irregular arrangement of the atoms in a crystal is called Non-Crystalline solids
- ❖ The atomic distance b/w any two successive atoms is not equal
Example: glass, rubber etc

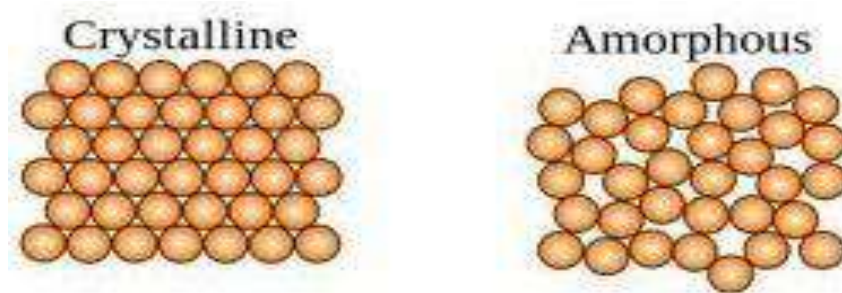

Fig: Crystalline and Non-crystalline materials

Anisotropy & Isotropy:

- The properties of polycrystalline solids may differ greatly in different directions and such an inequality of properties in various crystallographic directions is called **Anisotropy**.
- Amorphous substances such as glass will display the same properties in any directions or planes are called **isotropic**.

Lattice: It denotes the position of atoms or molecules in the crystal.

Space lattice: It differs from a crystal structure in that a space lattice is an array of points in three-dimensional space in which every point has surroundings identical to the every other point in the array. Whereas a crystal structure is an arrangement of atoms in crystal.

Or

The array of lattice points in three-dimensional space is called space lattice.

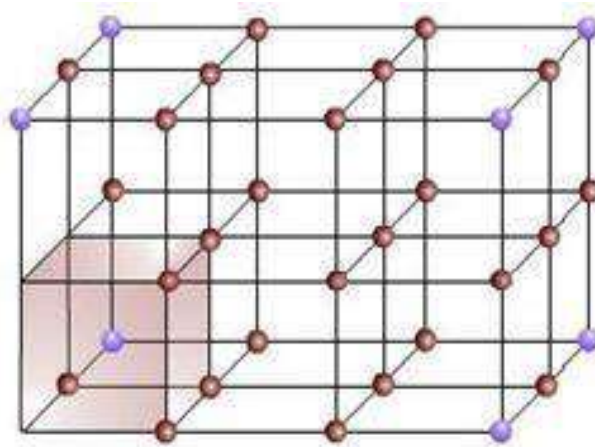

Representation of space lattice and unit cell

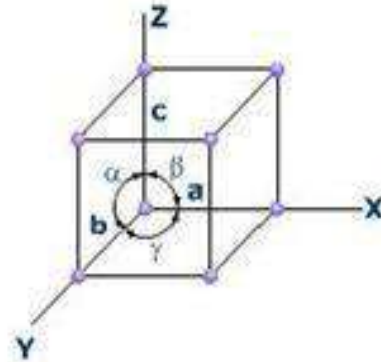

Representation of dimensions of a unit cell

Unit cell: It is the smallest portion of the crystal which shows the arrangement and position of atoms in a crystal structure

Where a, b, c - intercepts along axes along x, y, z and

α, β, γ - interfacial angles

Primitive cell: It is defined as a unit cell which possesses lattice points at its corners only

Example: A simple cubic cell

Non-Primitive cell: The unit cell which contain more than one lattice point, are called Non-primitive cell

Ex: body centered and face centered cubic structures contain more than one lattice point per unit cell

- ❖ If no of lattice points per unit cell are two the unit cell is called doubly primitive cell.
- ❖ If no of lattice points per unit cell are three or four the unit cell is called triply primitive cell or quadruply primitive cell

TYPES OF CRYSTAL SYSTEMS

Seven crystal systems are:

1. Cubic
2. Tetragonal
3. Orthorhombic
4. Monoclinic
5. Triclinic
6. Trigonal (Rhombohedral)
7. Hexagonal

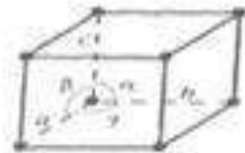

Representative Unit Cell (a)

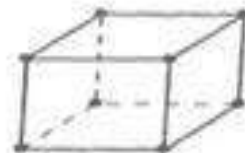

$a = b = c$
 $\alpha = \beta = \gamma = 90^\circ$
CUBIC (b)

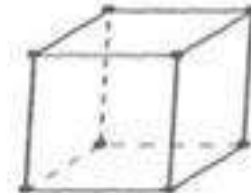

$a = b \neq c$
 $\alpha = \beta = \gamma = 90^\circ$
TETRAgonAL (c)



$a \neq b \neq c$
 $\alpha = \beta = \gamma = 90^\circ$
ORTHORHOMBIC (d)

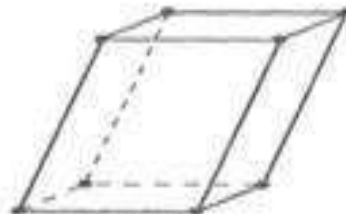

$a \neq b \neq c$
 $\alpha = \gamma = 90^\circ \neq \beta$
MONOCLINIC (e)

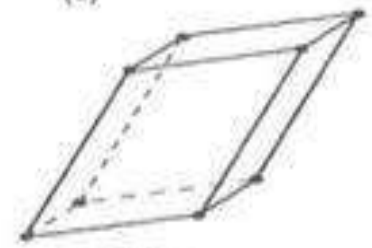

$a \neq b \neq c$
 $\alpha \neq \beta \neq \gamma \neq 90^\circ$
TRICLINIC (f)





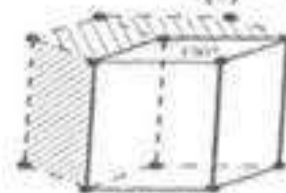





$a = b = c$
 $\alpha = \beta = \gamma \neq 90^\circ$
RHOMBOHEDRAL (TRIGONAL) (g)

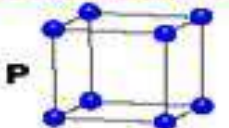
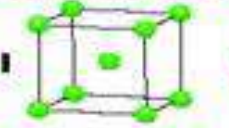

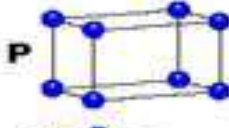
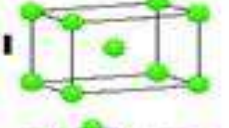
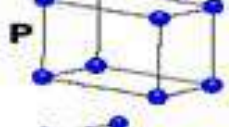
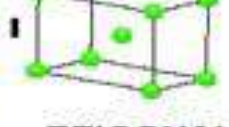
$a = b \neq c$
 $\alpha = \beta = 90^\circ, \gamma = 120^\circ$
HEXAGONAL (h)

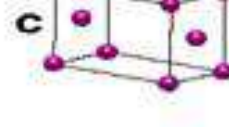
Bravais Lattice

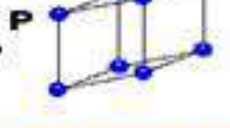
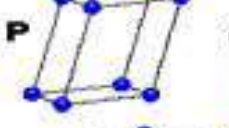
14 types of lattices, called *Bravais lattices*, make up the crystal system. The lengths of the sides, a, b, and c, and the angles between them can vary for a particular *unit cell*.

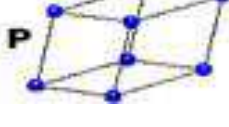
<p>CUBIC $a = b = c$ $\alpha = \beta = \gamma = 90^\circ$</p>				
<p>TETRAGONAL $a = b \neq c$ $\alpha = \beta = \gamma = 90^\circ$</p>				
<p>ORTHORHOMBIC $a \neq b \neq c$ $\alpha = \beta = \gamma = 90^\circ$</p>				
<p>HEXAGONAL $a = b \neq c$ $\alpha = \beta = 90^\circ$ $\gamma = 120^\circ$</p>		<p>TRIGONAL $a = b = c$ $\alpha = \beta = \gamma \neq 90^\circ$</p>		
<p>MONOCLINIC $a \neq b \neq c$ $\alpha = \gamma = 90^\circ$ $\beta \neq 120^\circ$</p>				
<p>TRICLINIC $a \neq b \neq c$ $\alpha \neq \beta \neq \gamma \neq 90^\circ$</p>				

4 Types of Unit Cell
 P = Primitive
 I = Body-Centred
 F = Face-Centred
 C = Side-Centred
 +
 7 Crystal Classes
 → 14 Bravais Lattices

Packing factor (p.f)

- Packing factor or packing density is defined as the volume occupied by the atoms in a unit cell to the volume of unit cell.
- Packing fraction = vol.of atoms in a unit cell / volume of unit cell

For a cubic structure, $p.f = n \cdot \frac{4}{3} \pi r^3 / a^3$

Where r = radius of atoms

n = effective no.of atoms per unit cell

a = lattice parameter of the structure

P.F is less then the atoms are arranged in loosely packed and when the P.F is more then the atoms are arranged in close packed

CRYSTAL STRUCTURE OF METALS

Most metals crystallize into 4 forms of crystal systems:

- ❖ Simple Cubic crystal structure (S.C.C)
- ❖ Face-centered cubic structure (F.C.C)
- ❖ Body-centered cubic structure (B.C.C)
- ❖ Hexagonal close-packed structure (H.C.P)

1. Simple cubic structure:

In this structure 8 corners of the cube are occupied by 8 atoms.

No of atoms in the unit cell of S.C.C:

The unit cell contains 8 atoms one at each corner of the cube, since each corner atom is shared by 8 eight surrounding cubes the unit cell of S.C.C contains

8 atoms at the corners $8 \times 1/8 = 1$ atom

Atomic packing factor of S.C.C:

P.F = vol.of atoms in a unit cell / volume of unit cell

Consider a s.c.c structure as shown in fig;

Where; a=length of each side of cube

r=atomic radius

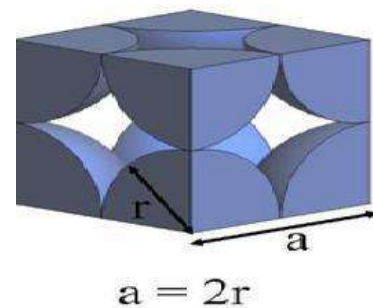
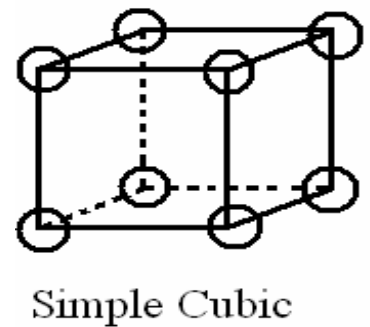

$$r = a / 2$$

$$\text{Volume of atoms in the unit cell} = n \cdot \frac{4}{3} \pi r^3$$

$$= 1 \times \frac{4}{3} \pi (a/2)^3 = \frac{\pi a^3}{6}$$

$$\text{Volume of unit cell} = a^3$$

$$p.f = (\frac{\pi a^3}{6}) / a^3 = \frac{\pi}{6} = 52 \%$$

$$AE = \sqrt{2}a$$

From $\triangle AEF$, $AF^2 = AE^2 + EF^2$

$$(4r)^2 = 2a^2 + a^2$$

$$16r^2 = 3a^2$$

$$a = 4r/\sqrt{3}$$

We know that;

$$\text{Volume of the unit cell} = a^3 = (4r/\sqrt{3})^3$$

$$\begin{aligned} \text{Volume of the atom in the unit cell} &= n \cdot \frac{4}{3} \pi r^3 \\ &= 2 \times \frac{4}{3} \pi r^3 \end{aligned}$$

Packing factor (p.f):

$$P.f = \frac{2 \times \frac{4}{3} \pi r^3}{(4r/\sqrt{3})^3} = 0.68 = 68\%$$

Examples- chromium, iron, molybdenum, potassium, sodium, tungsten, vanadium

P.f is 68% and it is not a closely packed structure.

Face-centered cubic structure:

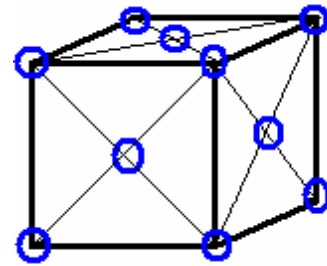
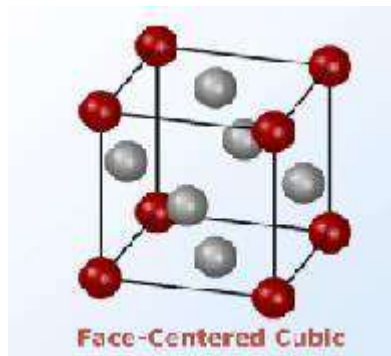

In FCC structure, there are eight corner of the cube occupied by eight atoms, and six atoms occupy the centre of six of the cube atoms

Examples- AL, copper, gold, lead, nickel, platinum, silver.

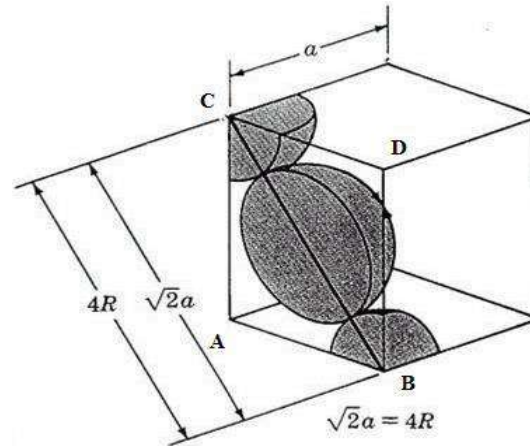
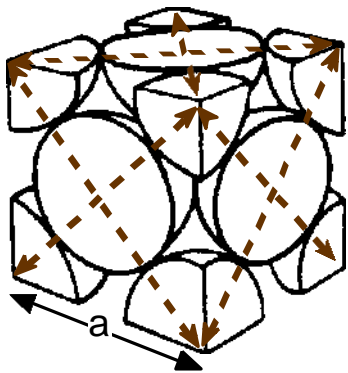

Effective no.of atoms: (n)

In FCC structure effective no.of corner atom is $8 \times 1/8 = 1$.

Each face centered atom is shared by two unit cells, there are six faces in a unit cell of cubic structure.

Therefore, the effective face-centered atoms = $1/2 \times 6 = 3$

Thus, effective no.of atoms in FCC unit cell,

$$n = 1/8 \times 8 + 1/2 \times 6 = 1 + 3 = 4 \text{ atoms}$$

Packing factor (p.f):

From ΔABC , $AC^2 = AB^2 + BC^2$

$$(4r)^2 = a^2 + a^2$$

$$16r^2 = 2 a^2$$

$$8r^2 = a^2 ; \quad a = 2 \times \sqrt{2}r$$

We know that;

$$\text{Volume of the unit cell} = a^3 = (2 \times \sqrt{2}r)^3$$

$$\text{Volume of the atom in the unit cell} = n \cdot \frac{4}{3} \pi r^3$$

$$= 4 \times \frac{4}{3} \pi r^3$$

Packing factor (p.f): $P.f = \text{Volume of the atom in the unit cell} / \text{Volume of the unit cell}$

$$= 4 \times \frac{4}{3} \pi r^3 / (2 \times \sqrt{2}r)^3$$

$$= 0.74 \text{ or } 74\% \quad \text{P.f is high compared to S.C.C and B.C.C}$$

Hexagonal close-packed (HCP) structure:

Crystal Structure of Metals

Hexagonal Closed-Packed (HCP)

- In HCP structure, the atoms are placed as tight as possible
- The corner atoms are shared by six unit cells, face atoms are shared by adjacent two cells, and the interior atoms are shared by only one cell

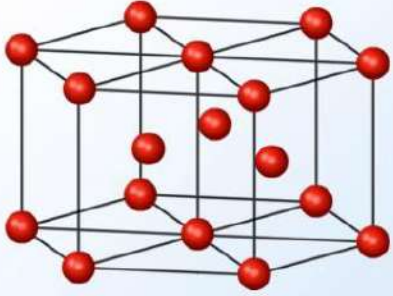

Hexagonal Closed-Packed

The atoms in HCP unit cell touch each other.

Since the corner atoms are touching, $a = 2r$

Effective no. of atoms: (n)

There are six corner atoms on both top and bottom layers and each corner atom accounts for 1/6 atom.

Thus contribution from the corner atoms is $2(1/6 \times 6) = 2$.

Also, there are 3 atoms in the middle layer which are not shared by any other unit cell.

The atoms at the center of top and bottom layers one atom ($1/2 \times 2 = 1$)

Thus, effective no. of atoms in HCP unit cell,

$$n = 2(1/6 \times 6) + 3 + (1/2 \times 2) = 2 + 3 + 1 = 6$$

Packing factor (p.f):

Volume of unit cell can be found by finding out the area of the basal plane and then multiplying this by its height

Area of basal plane is the area ABDEFG.this area is six times the equilateral triangle ABC

Area of $\triangle ABC = 1/2 \times b \times h$

$$= 1/2 \times a \times a \sin 60^\circ$$

$$= 1/2 \times a^2 \times \sin 60^\circ$$

Total area of the basal plane = $6 \times 1/2 a^2 \sin 60^\circ = 3 a^2 \sin 60^\circ$

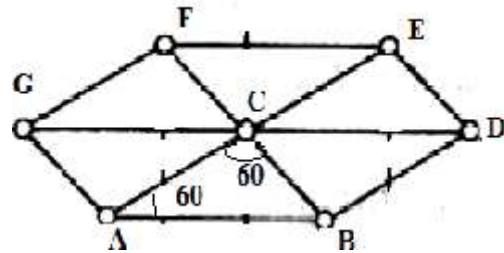
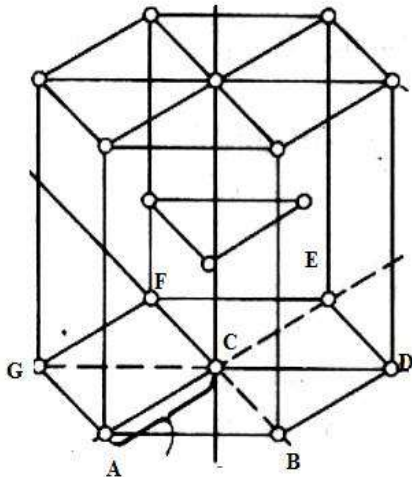

Vol of unit cell = Area of basal plane x height

$$= 3 a^2 \sin 60^\circ \times c$$

We know; $a = 2r$

Vol of atoms in unit cell = $n \cdot \frac{4}{3} \pi r^3 = 6 \cdot \frac{4}{3} \pi r^3$

Packing factor (p.f):= Volume of the atom in the unit cell/ Volume of the unit cell

$$= \frac{6 \cdot \frac{4}{3} \pi (a/2)^3}{3a^2 \sin 60^\circ c}$$

$$= \frac{\pi a}{3xc} \sin 60^\circ$$

The c/a ratio for ideal H.C.P crystal structure is 1.633

$$= \frac{\pi}{3} \times 1.633 \times \sin 60^\circ = 0.74 \text{ or } 74\%$$

Examples - cadmium, zinc, magnesium, cobalt, zirconium, titanium, beryllium.

P.f is 74% and hence it is closely packed structure.

CRYSTALLIZATION OF METALS

- Crystallization or solidification is the process of transition from the liquid state. When the molten metal is cooled, the whole mass does not solidify instantaneously.

It comprises two steps

1. Nucleation (the formation of stable nuclei in the melt)
2. Grain or crystal growth (the growth of nuclei into crystal and the formation of the grain structure.)

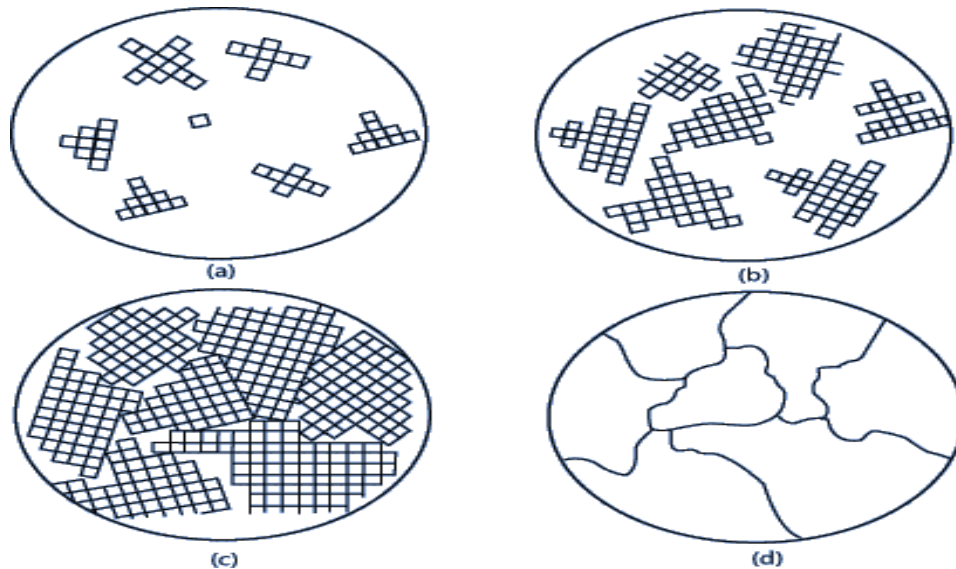

GRAIN

Solidified metal containing many crystals is called polycrystalline metals. The crystals in polycrystalline metals are of irregular shape and are called grains.

GRAIN BOUNDARIES

A **grain boundary** is the interface between two [grains](#), or crystallites, in a polycrystalline material

Or

A grain boundary may be defined as the region b/w two adjacent grains

The grain size expressed in terms of number of grains per unit area or volume

Factors affecting grain size

- Size of grain depends on rate of nucleation and rate of crystal growth
- The combination of high rate of nucleation (N) with a slow rate of crystal growth (G) yields fine grains this combination can be achieved due to rapid cooling
- At faster rate of cooling a large no of grains are nucleated and there is less time for them to grow
- A high value of (G) and low value of (N) coarse grains are formed this combination can be achieves in slow rate of cooling
- Besides the rate of cooling and rate of nucleation the grain size also depends on the temperature of liquid metal, the chemical composition and the impurities present there in
- When the grain size is small the structure of the metal is known as “**fine grained structure**”
- When the grain size is large the structure of the metal is known as “**coarse grained structure**”
-

Effect of grain size on properties:

- The grain size of the metal strongly effects its mechanical properties
- Metals and alloys are stronger if the grain size is reduced there fore every effort is made to produce structure with fine grains
- Metals with fine grain structure possess high strength and hardness also they possesses high fatigue strength and toughness (i.e, resistance to impact).
- Metals with coarse grain structure possesses less tough and less hard but exhibit better creep resistance
- Coarse grain structure gives high ductility good machinability and formability but decrease the hardenability

- The relationship between the yield strength of the metal and the grain size is given by Hall-Petch equation, which is

$$\sigma_{\text{yield}} = \sigma_{0\text{yield}} + \frac{k}{\sqrt{d}}$$

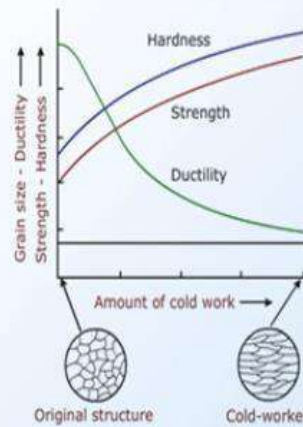

Effect of Grain Boundaries on the Properties of Metal/Alloys

GRAIN SIZE DETERMINATION

Three basic methods has recomodded by ASTM (AMERICAN STANDARD TESTING AND MATERIALS)

1. Comparison method
2. Heyn method or intercept method
3. Planimetric method or Jeffries method

1. Comparison method:-

In this method the grain size is measured by comparison under a magnification of 100X(after etching)with standard grain size AS

- The ASTM grain-size number n is related to N , the number of grains per square inch at a magnification of 100x by the relationship $N^* = 2^{n-1}$

Where N = no of grains per inch square at a magnification of 100 X
 n =ASTM grain size number

2. Heyn method or intercept method :

Grain size may be estimated by using an intercept method, described below:

- Straight lines, all of the same length are drawn through several photomicrographs that show the grain structure.
- The grains intersected by each line segment are counted.
- The line length is then divided by an average of no. of grains intersected, taken over all the line segments.
- The average grain diameter is found by dividing this result by the linear magnifications of the photomicrographs.

To each assigned a number, the smaller the grains.

A specimen must be properly of 100x.

Grain size is expressed as the grain size no of the chart that most nearly matches the grains in the micrograph.

Thus, a relatively simple and convenient visual determination of grain size number is possible.

Grain size number is used extensively in the specification of steels.

IMPERFECTIONS IN CRYSTALS

The perfectly regular crystal structures that have been considered upto now are called ideal crystals in which atoms are arranged in a regular way.

In actual crystals, however, imperfections or defects are always present and their nature and effects are very important in understanding the properties of crystals.

These imperfections affect the properties of crystals such as mechanical strength, chemical reactions, electrical properties etc. to a great extent.

Crystal defects are classified as :

- Point defects or zero dimensional defect
- Line defects or one dimensional defect
- Surface defects or two dimensional defect
- Volume defect

1. Point defects:

Point defects are imperfect point like regions in a crystal. The size of a point defect is one or two atomic diameters.

These defects are completely local in effect, e.g., a vacant lattice.

Point imperfections are always present in crystals and their presence results in a decrease in the free energy.

The point defects may be created as follows:

- By thermal fluctuations
- By quenching (quick cooling) from a higher temperature
- By severe deformation of the crystal lattice; e.g., by hammering or rolling.

The various point defects are discussed as below:

1. Vacancy

A vacancy is the simplest point defect and involves a missing atom within a metal. These defects may come up as a result of imperfect packing during the original crystallization.

They may also arise from the thermal vibrations of the atoms at high temperatures.

2. Schottky imperfections

These are closely related to vacancies but are found in compounds which must maintain a charge balance.

In a Schottky defect the removal of a positive ion must be counterbalanced by the removal of a negative ion in order to maintain neutrality.

The pair of vacancies caused by removal of a positive ion and a negative ion is called a Schottky defect.

3. Interstitialcy

It is formed when an extra atom is inserted into the lattice at a normally unoccupied site. This results in atomic distortion.

The foreign atom may form an added alloying agent or simply an impurity.

The vacancy and interstitialcy are therefore, inverse phenomena.

4. Frenkel defect

If an ion is displaced from the normal lattice point to an interstitial site, then the defect is known as a Frenkel defect.

The interstitials and frankel defects are less in number than vacancies and schottky defects, because additional energy is required to force the atom into the new position.

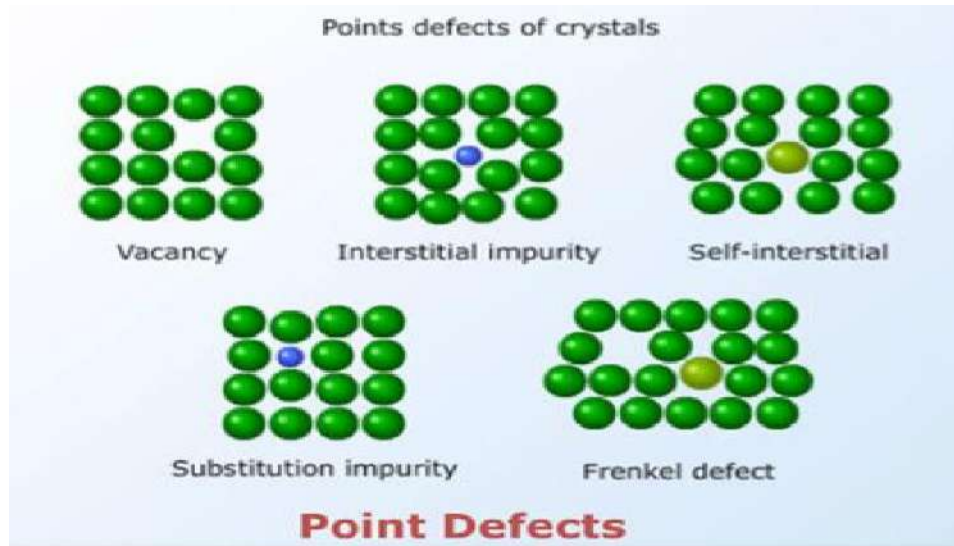

2. Line defects:

- A linear disturbance of the atomic arrangement, which can move very easily on the slip plane through the crystal is known as dislocation.
- This dislocation may be caused during growth of crystal from a melt or from a vapour or they may occur during a slip.
- This defect is created along a line which is also the boundary between the slipped and unslipped regions of the crystal. This defect is commonly called a “dislocation” and the boundary as the “dislocation line”.

Types of dislocations are:

- Edge dislocation (or Taylor-Orowan dislocation)
- Screw dislocation

1. Edge dislocation

- An edge dislocation may be described as an extra plane of atoms within a crystal structure. It is accompanied by zones of compression and tension so that there is a net increase in energy along a dislocation.
- The displacement distance for atoms around the dislocation is called the “BURGER VECTOR”(b). This vector is at right angle to the edge dislocation.
- In case of edge dislocation this vector is perpendicular to the dislocation line

2. Screw dislocation

- In screw dislocation the atoms are displaced in two separate planes perpendicular to each other.
- The lattice points trace a helical path around the dislocation, therefore it is called “screw dislocation”.
- A screw dislocation has its displacements of burger’s vector parallel to the linear defect but there is a distortion of the plane.
- The displacements of the atoms from their original position in the crystal is described by the equation:
 - $r = b\theta/2\pi$ (spiral ramp)
 - where, r = the displacement along the dislocation line,
 - θ = the angle measured from some axis perpendicular to the dislocation line.
- The following dislocation of a screw dislocation are of great importance:
- Plastic deformation is possible under low stress, without breaking the continuity of the lattice.
- The force required to form and move a screw dislocation is probably somewhat greater than that required to initiate an edge dislocation.
- Screw dislocation causes distortion of a considerable distance from the centre of the line and takes the form of spiral distortion of the planes.
- Dislocation of both types (combinations of edge and screw) are closely associated with crystallization as well as deformation

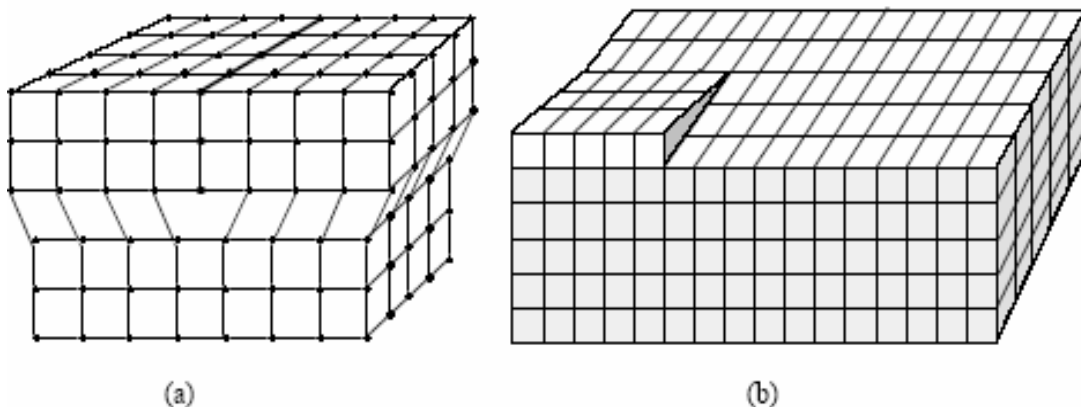

Line defects. (a) Edge dislocation. (b) Screw dislocation.

3. Surface defects:

Surface defects are the two dimensional regions in a crystal. They arise from a change in the stacking of atomic planes on across a boundary.

They are the following two types:

- External defects
- Internal defects

1. External defects

- The external type is just what its name implies, the defects or imperfections represented by a boundary.
- The external surface of the material is an imperfection itself, because the atomic bonds do not extend beyond it.
- The surface atoms have neighbours on one side only, while the atoms inside the crystal have neighbours on either side of them.
- Since these surface atoms are not entirely surrounded by others, they possess higher energy than those of internal atoms.

2. Internal defects

a) Grain boundaries:

- Grain boundary is a narrow region between two grains of about two to few atomic diameters in width, and is the region of atomic mismatch between adjacent grains.
- Atoms are arranged less regularly at the grain boundary. This produce less efficient packing of the atoms at the boundary.
- Thus the atoms along the grain boundary have a higher energy than those within the grains.
- If the orientation between two neighbouring grains is less than 10^0 , then it is called low angle boundary or tilt boundary. In general low angle boundary may be regarded as an array of dislocations.
- If the mismatch is more than $10-15^0$, the grain boundary is known as high angle grain boundary.

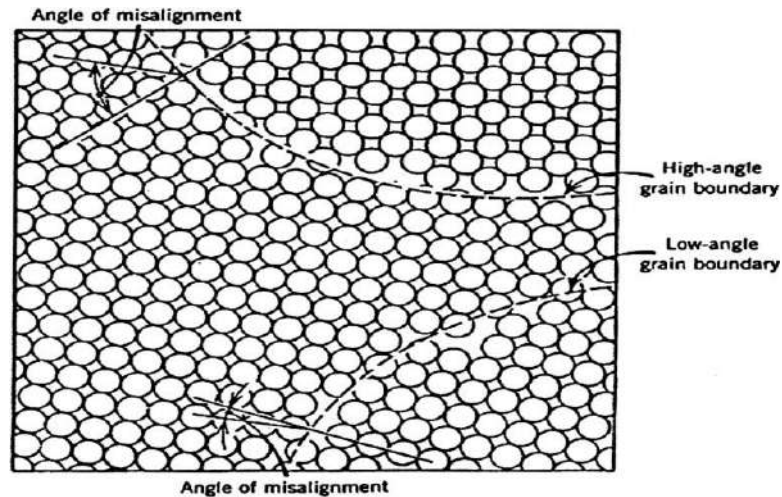

At the grain boundary, there is a disturbance in the atomic packing.

b) Tilt boundary:

- The simplest grain boundary consists of a configuration of edge dislocations between two grains.
- The misfit in the orientation of the two grains (one on each side of the boundary) is accommodated by a perturbation of the regular arrangement of crystals in the boundary region.
- Fig shows some vertical atomic planes termination in the boundary and each termination is represented by an edge dislocation.

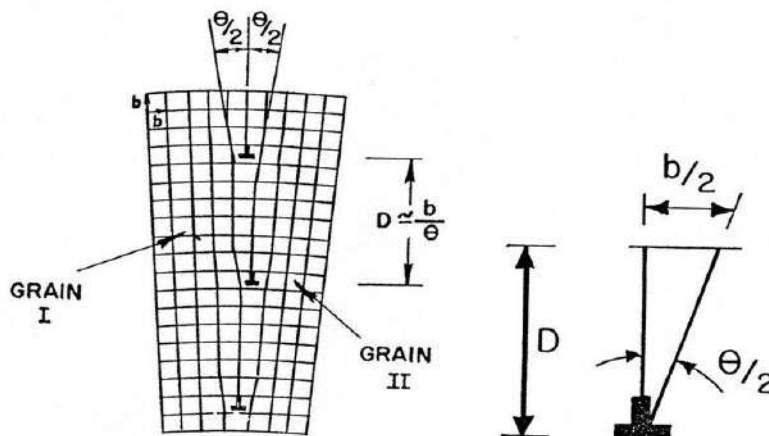

Low-angle tilt boundary

- The mis-orientation at the boundary is related to spacing between dislocations, D , by the following relation:

$$D = \frac{b}{2 \sin\left(\frac{\theta}{2}\right)} \approx \frac{b}{\theta}$$

for q very small)

where b is the Burgers vector.

- As the mis-orientation q increases, the spacing between dislocations is reduced, until, at large angles, the description of the boundary in terms of simple dislocation arrangements does not make sense.
- For such a case, θ becomes so large that the dislocations are separated by one or two atomic spacing;
 - the dislocation core energy becomes important and the linear elasticity does not hold.
 - Therefore, the grain boundary becomes a region of severe localized disorder.
- Boundaries consisting entirely of edge dislocations are called tilt boundaries, because the misorientation

c) Twist (twin boundary)

- A boundary consisting entirely of **screw dislocations** is called **twist boundary**, because the misorientation can be described by a relative rotation of two grains about an axis.
- It is possible to produce misorientations between grains by combined tilt and twist boundaries. In such a case, the grain boundary structure will consist of a network of edge and screw dislocations.

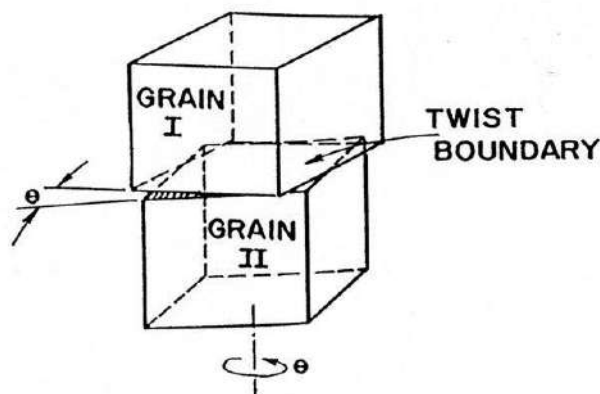

Low angle twist boundary

Twin Boundary: when the boundaries in which the atomic arrangement on one side of the boundary is some what mirror image of the arrangement of atoms of other side, the defect is known twin boundary

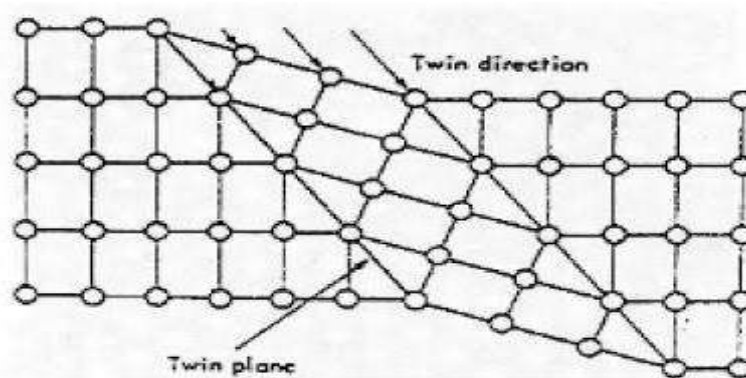

4. volume defects:

- the volume defects are caused due to coglomerations of vacancies in a small region within crystal or the presence of foreign atoms large sizes compared on atomic scale.
- The accumulation of vacancies produces voids, while the foreign atoms produce dissymmetry within crystals.
- These defects effects properties of metal.
- Bulk or volume defects are normally introduced during processing processing and fabrication steps.

THEORY OF DISLOCATION

- Dislocations are defined as the irregularities in the structure of metals.
- These arise from misplacement of bonds the atoms in a part of the plane of a crystal and are considered to be weak centres.
- They are instrumental in affecting the breaking stress and plastic and chemical properties of crystals.
- It is believed that dislocations originate mainly when a crystal is stressed, but some may be produced during the solidification of the metal, due to impurity atoms and thermal vibrations.
- In good crystals the normal density of dislocation lines is around $10^8/\text{cm}^2$ where as in deformed crystals it may be as high as $10^{12}/\text{cm}^2$.

IMPORTANT TERMS

System: A part of the universe under study is called system.

Phase:Phase is a homogeneous, physically distinct and mechanically separable part of the system under study.

Component: Pure metal of which the alloy is composed.

Solubility limit:Maximum concentration of solute that can dissolve in solvent

Variable: A particular phase exists under various conditions of temperature, pressure and concentration. These parameters are called as the variables of the phase.

Component:The elements present in the system are called as components.

Example- Cu-Al system contains compounds CuAl and CuAl₂ and therefore, all compositions can be expressed by the molecular species of Cu and Al and hence it is two component system i.e. binary system.

Alloy:

Alloy is mixture of two or more elements having metallic properties. The element present in the largest proportions is a metal and others can be metals or non-metals.

The element which is present in the largest amount is called as the base metal or parent metal or solvent and other elements are called as alloying elements or solute.

Constitution:

- The constitution of an alloy is described by
 - the phases present
 - the weight fraction of each phase
 - the composition of each phase
- The equilibrium constitution is when the alloy has no further tendency to change at a given temperature and pressure

ALLOYING ELEMENTS

The elements deliberately added to the steel in order to modify its properties are called alloying elements.

Classification of alloying elements:

1. Based on their relation with carbon, alloying elements may be classified as:

- Graphitizing elements – silicon, nickel, copper and aluminium.

These elements may cause the breakdown of cementite and lead to the presence of graphite in the alloy. This results in a decrease in the strength and hardness.

- Carbide forming elements – manganese, chromium, molybdenum, tungsten, etc.

These elements may form stable, hard carbides, and if they are in appropriate form (fine carbide particles) increases the strength and hardness.

- Neutral elements – cobalt

These elements neither form carbides nor cause graphitization.

2. Based on their effect on critical points, alloying elements may be classified as:

- Austenite stabilizers – nickel, copper, manganese, cobalt

They raise the A_4 point and lower the A_3 point. Thus they increase the range of stability of austenite.

- Ferrite stabilizers – chromium, molybdenum, vanadium

They lower the A_4 point and raise the A_3 point. Thus they increase the range of stability of ferrite.

Necessity of alloying:

Alloying elements are added to achieve the properties suitable for service conditions. The reasons for alloying may be one or more of the following.

- To improve the hardness and wear resistance.
- To improve corrosion resistance.
- To improve magnetic and electrical properties.
- To improve strength and toughness.

- To improve machinability, weldability, hardenability.
- To retain properties at elevated temperature.
-

SOLID SOLUTION

A solid solution is formed when two metals are completely soluble in solid state and also completely soluble in liquid state.

In other words, when homogeneous mixture of two or more kinds of atoms (metals) occur in the solid state, they are known as a solid solutions.

Types of solid solution:

- Substitutional solid solution
- Interstitial solid solution
- **Substitutional solid solution:**
 - it means the atoms of B element i.e solute are substituted at the atomic sizes of A element i.e solvent.
 - Depending up on the distribution of B atoms in A, Substitutional solid solutions are classified into two types
 - Regular or ordered
 - Random or disordered

In regular solid solution, the substitution of B atoms in A by a definite order.

While there is no definite order or regularity in random solid solution.

- Au-Cu solid solution shows ordered structure upto 400⁰C and disordered structure at high temperature.
- Complete regularity through the structure is possible only when two metals are mixed in some proportion like 1:1, 3:1 etc.
- Substitutional solid solution formation is favored if the atomic sizes of two metals are nearly equal.
- Ordered substitutional solid solution alloys in general are hard and require more energy for plastic deformation than disordered substitutional solid solution alloys.

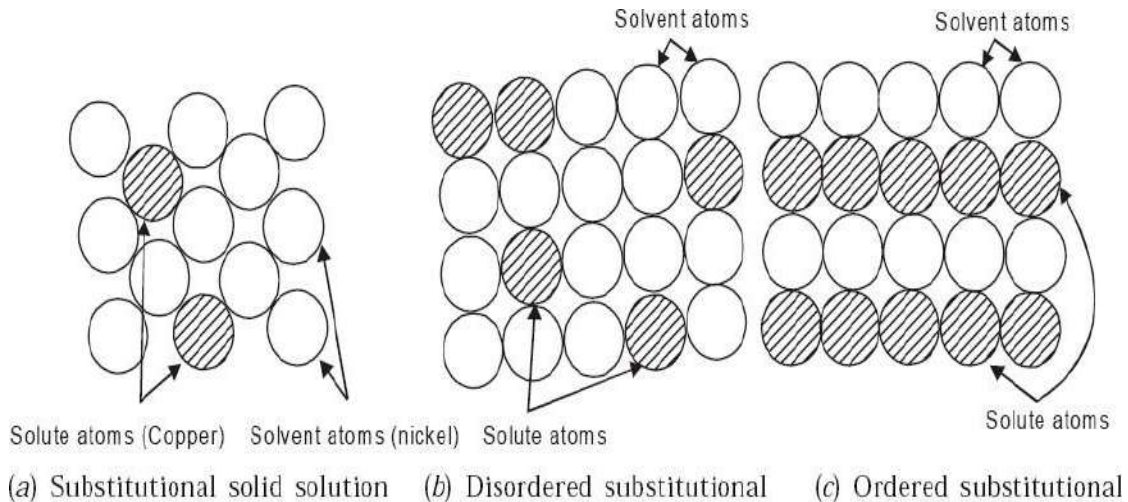

• **Interstitial solid solution:**

- In inter solid solutions; the atoms of B occupy the interstitial sites of A.
- This type of solid solution formation is favored when the atomic size of B is very much smaller as compared to the atomic size of A.
- The elements which can form interstitial solid solution with iron are carbon, boron, oxygen, hydrogen, nitrogen.

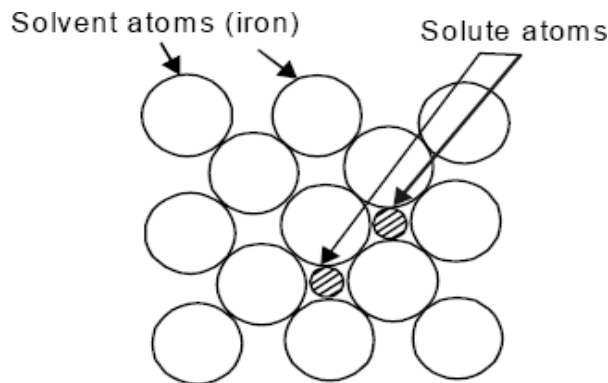

• **Properties of solid solution**

- Soft
- Ductile
- Malleable

• **Advantages of solid solution**

- Easily cold rolled
- Pressed or worked

HUME-ROTHERY'S RULES OF SOLID SOLUBILITY

In formation of solid solutions, the solubility limit of solute in the solvent is governed by certain factors. These factors are known as Hume-Rothery rules of solid solubility. They are as below:

- **Atomic size factor:**
 - If the atomic sizes of solute and solvent differ by less than 15%, it is said to have a favorable size factor for solid solution formation.
 - If the atomic size difference exceeds 15%, solid solubility is limited.
- **Chemical affinity factor:**
 - The greater the chemical affinity of two metals, the more restricted is their solid solubility and greater is the tendency of formation of a compound.
- **Relative valency factor:**
 - A metal of higher valency can dissolve only a small amount of a lower valency metal.
 - While the lower valency metal may have good solubility for the higher valency metal.
- **Crystal structure factor:**
 - Metals having same crystal structure will have greater solubility.
 - Differences in crystal structure limit the solid solubility.

For continuous solid solubility, atomic size difference should preferably be less than 8% with other factors favorable.

INTERMEDIATE ALLOY PHASES AND ELECTRON COMPOUNDS

- When an alloying element (solute) is added to a given metal (solvent) in such an amount that the limit of solid solubility is exceeded, a second phase appears with the solid solution.
- This second phase may be another solid solution or an intermediate phase.

- These intermediate phases differ in composition as well as crystal structure from the parent metals and hence their properties also different.
- These phases may have narrow or wide ranges of homogeneity and may or may not have simple chemical formula.
- Some intermediate phases have a fixed composition and they are called intermetallic compounds
- In general intermetallic compounds are hard, brittle and have high melting points.
- The intermediate phases in which the ratio of number of free electrons to the number of atoms is constant are called **electron compounds** and they exhibit similar characteristics.
- Intermediate phases exhibit order-disorder transformation.

Example- β brass in Cu-Zn alloy system is disorder between 453 and 470⁰C and order at a lower temperature.

Equilibrium of Diagrams

Introduction

- Equilibrium is the state achieved in an allotted sufficient time
- Sometimes, the time in which this equilibrium is achieved might get to be so long (the kinetics can be slow) that a state along the path to the equilibrium may seem to be stable. This is called a metastable state

Importance and Objectives:

- It provides the knowledge of phase composition and phase stability as a function of temperature, pressure and composition
- It presents the phase existed at a glance of equilibrium conditions of temperature and composition of the alloy

Classification of Equilibrium Diagrams

Unary Phase Diagram

- It is a one component phase diagram
- Pressure is plotted on the vertical axis and temperature on the horizontal axis as shown in image

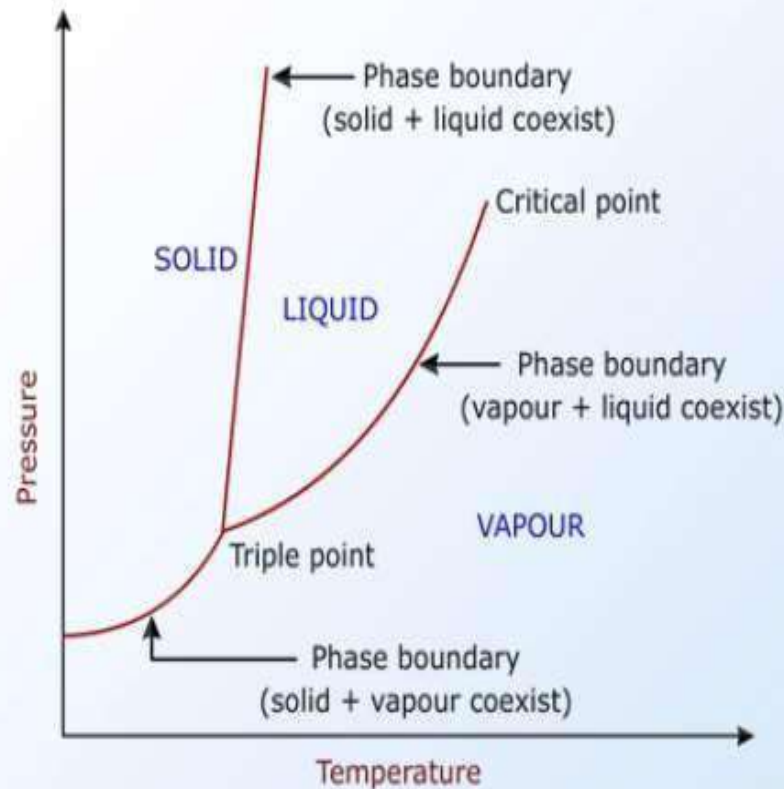

Pressure-Temperature Diagram for Water

Classification of Equilibrium Diagrams

Binary Phase Diagram

- It is a two component phase diagram
 - Pressure (P)
 - Temperature (T)
 - Compositional changes (X) on a 2d diagram

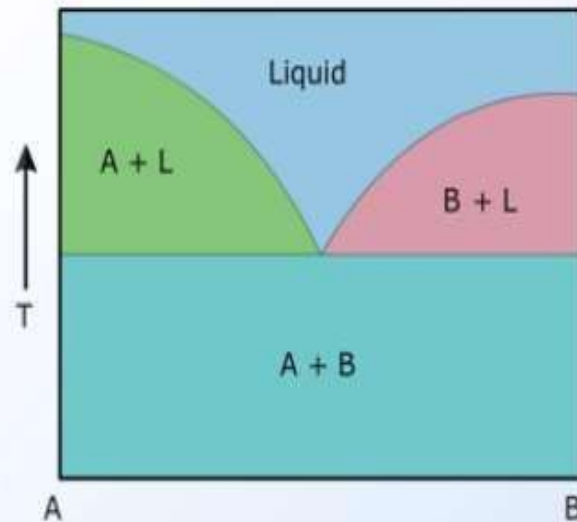

Example:

Diopside - Anorthite

Albite - Quartz

Simple Eutectic, No SS

Classification of Equilibrium Diagrams

Ternary Phase Diagram

- In most cases, real materials are combination of different elements instead of pure substances. Besides temperature and pressure, composition is also a variable
- Phase diagrams for materials with more than two components are complex and difficult to represent

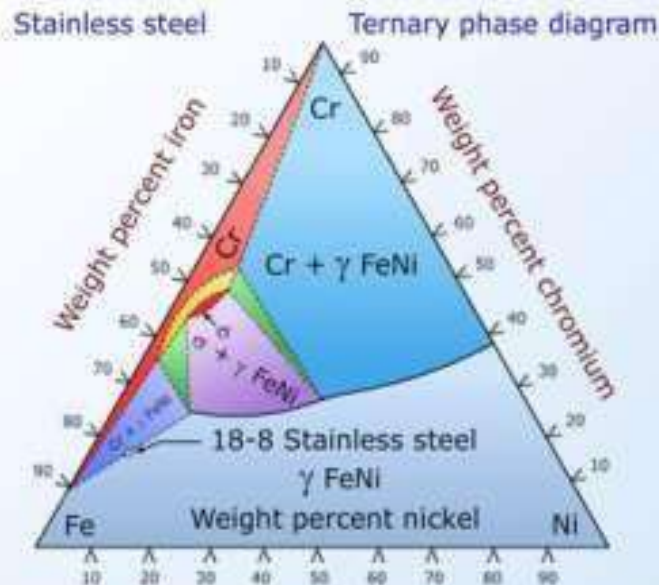

Ternary Phase Diagram

Construction of Equilibrium Diagrams

Metallographic Methods

- This method is practiced by heating samples of an alloy to different temperatures, awaiting the establishment of equilibrium, and then rapidly cooling to restore their structure (structure during high-temperature)
- The samples are then examined microscopically
- The rapidly cooled metals do not always retain their high-temperature structure

Gibbs' Phase Rule

Statement:

- The interconnection of the number of degrees of freedom, the number of components and the number of phases is given by the phase rule
- The following relation must be satisfied for all the metals under equilibrium conditions,

$$P + F = C + n$$

Solidification of a Pure Metal

- Solidification occurs by the nucleation and growth of crystals in the melt
- Nucleus is the small cluster of atoms having the right crystalline arrangement
- At any temperature below the melting point, a nucleus has to be of a certain minimum size, called the critical size
- When the temperature is lowered, the vibrations of the atoms gradually decreases, increasing the chances of survival of small clusters. Therefore, the critical size of the nucleus decreases with decreasing temperature

Cooling Curve of a Pure Metal

- Plotting a cooling curve for a pure metal will exhibit a horizontal line at its melting or freezing temperatures
- Between A and B, the metal exists in a "liquid" state
- Freezing starts at B and completes at C. Between B and C the metal is in the "liquid + solid" state
- Below the point C the metal is in "Solid" state

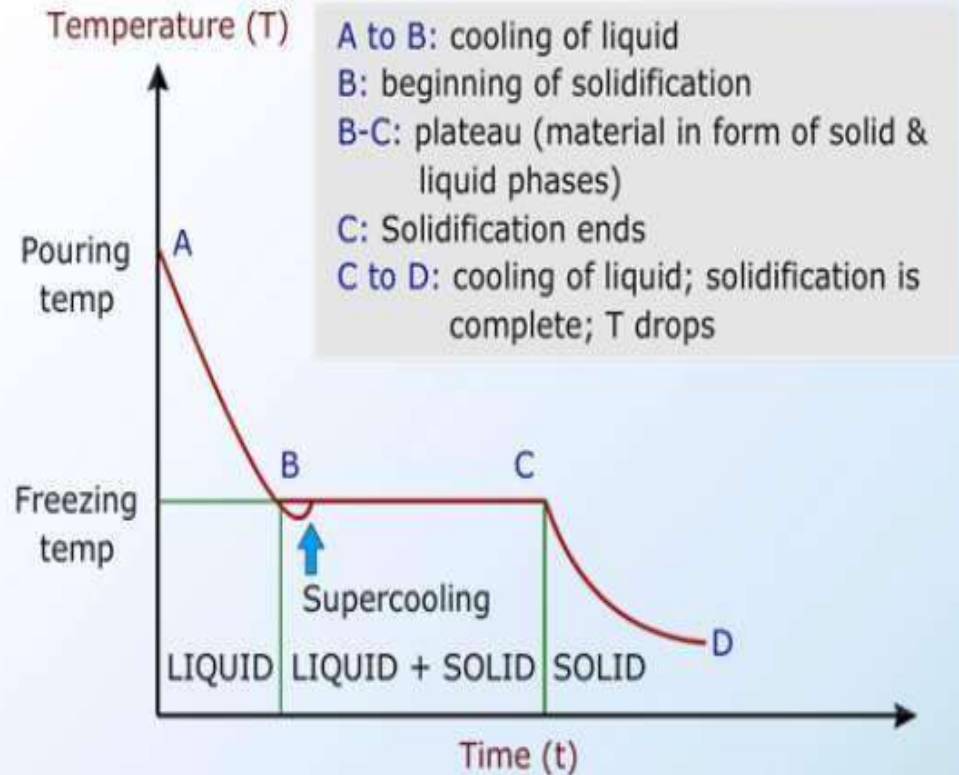

Cooling Curve of a Pure Metal

Construction of Equilibrium Diagrams

X-ray Diffraction Technique

- This method is practiced by measuring the lattice dimensions and representing the appearance of a new phase, either by change observed in lattice dimension or by the advent of a latest crystal structure

Thermal Analysis

- By constructing a cooling diagram for each amalgam, the temperature change in the initial and final phase is determined
- Phase diagrams are constructed by using these measured temperatures

Cooling Curve of a Solid Solution

- A solution in solid state consisting of the combination of two types of atoms in one space lattice form is called a solid solution
- A solute is the minimal part of the solution or the metal that is dissolved
- During the solidification of the solution, the temperature may not be equal to freezing point of the pure solvent

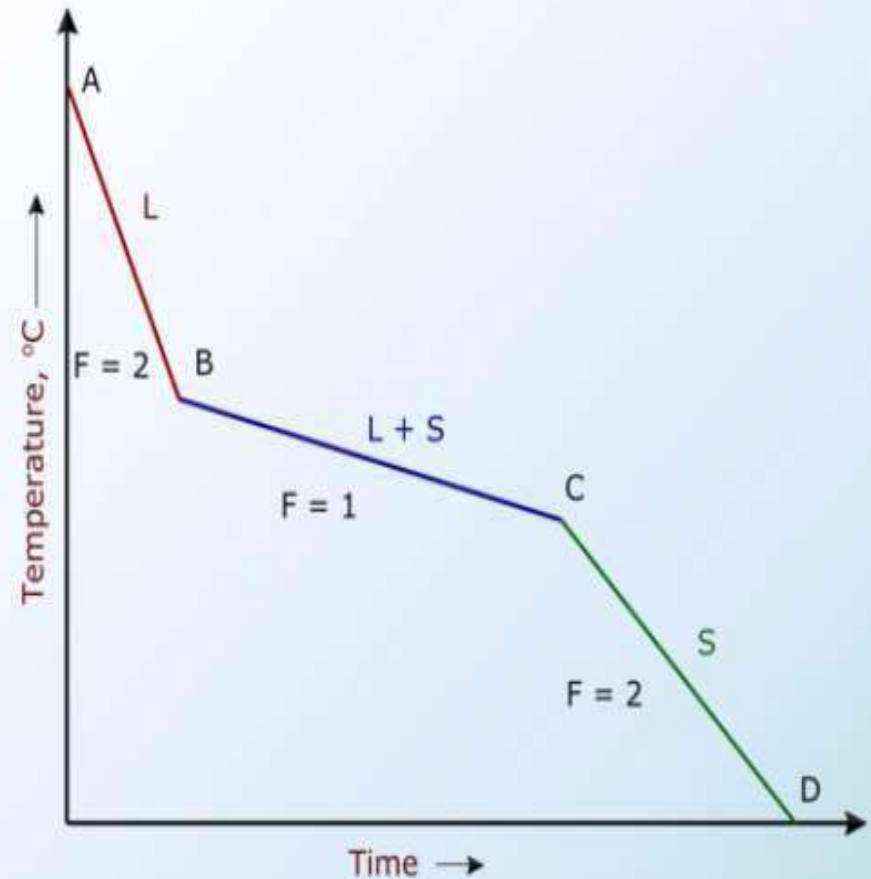

Cooling Curve of a Solid Solution

Thermal Analysis Method

- Most common method used for construction of equilibrium or phase diagrams is the 'Thermal Analysis Method'

Step 1: Prepare large number of alloys of varying compositions.

Step 2: Plot curves of the above materials as shown in image.

Step 3: Transfer these temperatures to a 'Temperature Vs. Composition' graph as shown in the image.

Step 4: Draw smooth curves through the points $L_1, L_2, L_3, L_4, \dots, L_{10}, L_{11}$, and $S_1, S_2, S_3, S_4, \dots, S_{10}, S_{11}$ respectively which represents the liquidus and solidus temperature diagrams as shown in image

Thermal Analysis Method

- At any temperature T , the average composition of the existing liquid is given by the point X and average composition of the existing solid is given by the point Y as shown in image

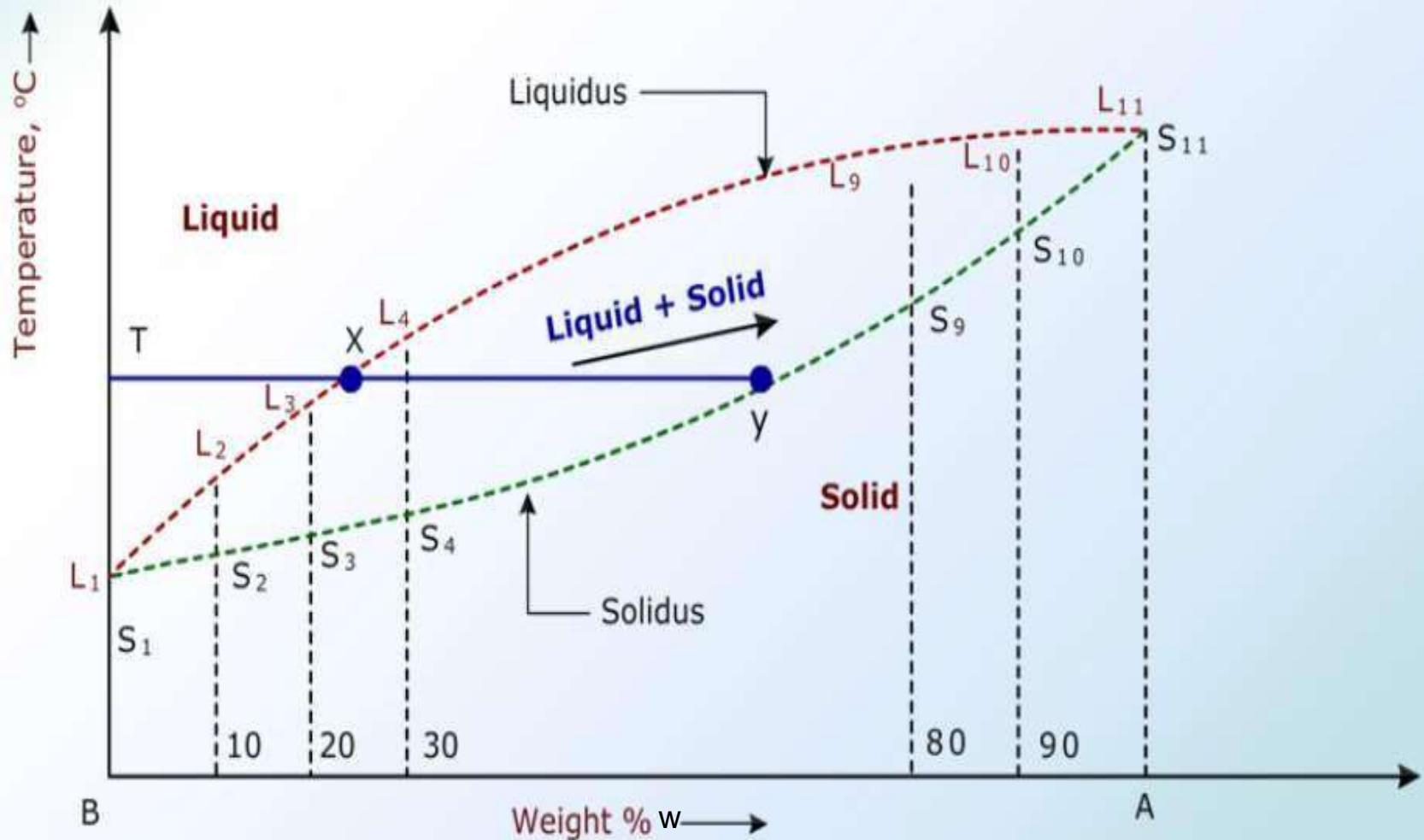

Lever Rule

- Lever rule is used for finding the amounts of phases existing in a binary system for a given alloy at any temperature under consideration

The amount of B
in the alloy

=

The amount of B
in the solid

+

The amount of B
in the liquid

(Amount of solid) x (Its lever Arm) = (Amount of liquid) x (Its lever Arm)

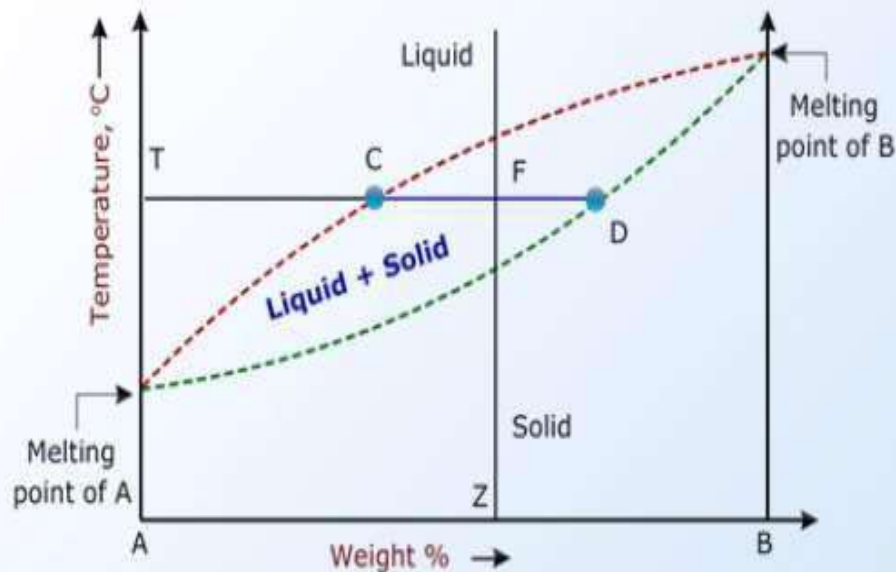

Lever Rule

Common Types of Phase Diagrams

- The most common types of phase diagrams are:
 - Isomorphous Systems
 - Eutectic Systems
 - Partial Eutectic Systems
 - Layer Type Systems

Properties of Alloys

Specific Heat and Coefficient of Thermal Expansion:

- These properties of alloys are governed by the law of mixtures.

Melting point:

- Greater the difference in valencies between the metals of alloys, the wider is the melting range.

Boiling point:

- Boiling point (like melting point) is transformed into a boiling range by the adding alloying element.

Isomorphous Systems

- The main conditions for complete solubility in the solid state are:
 - Two components should have the same crystal structure
 - Size of the atoms should be very similar
- Let us consider the solidification of the alloy containing 60% of metal B

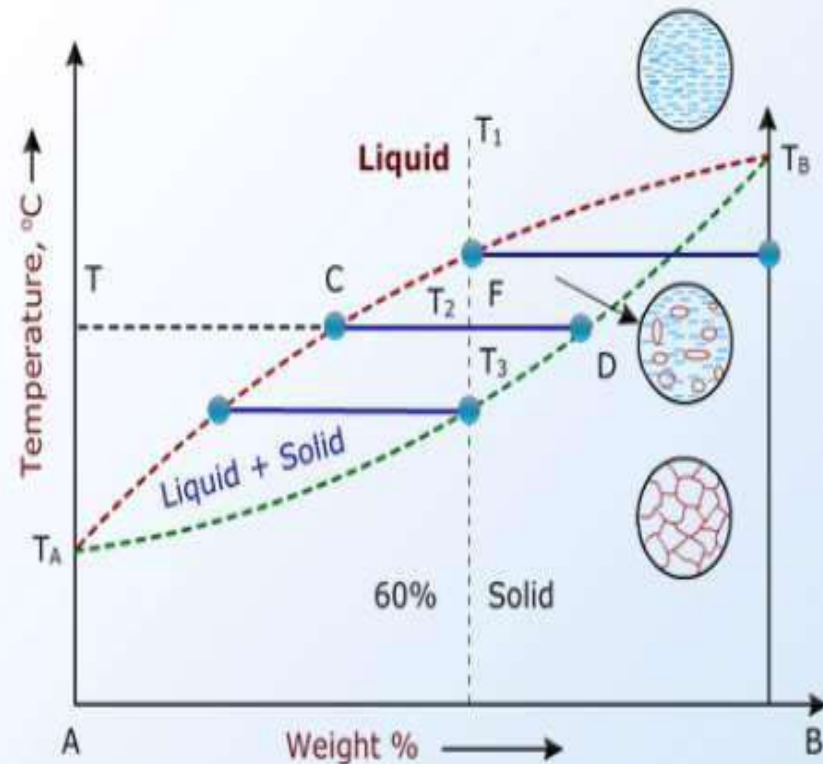

Isomorphous Systems

- Freezing starts at the temperature T_1 . Here, the first crystal of the solid solution of metals A and B separate from the liquid alloy
- In liquid phase at equilibrium, the concentration of the solid solution is determined by the point of crossing of a horizontal line which passes through the specified temperature with the solidus

Copper-Nickel Phase Diagram

- Lever rule is employed for finding out the amounts of phases existing in a binary system for a given Cu-Ni alloy at any temperature

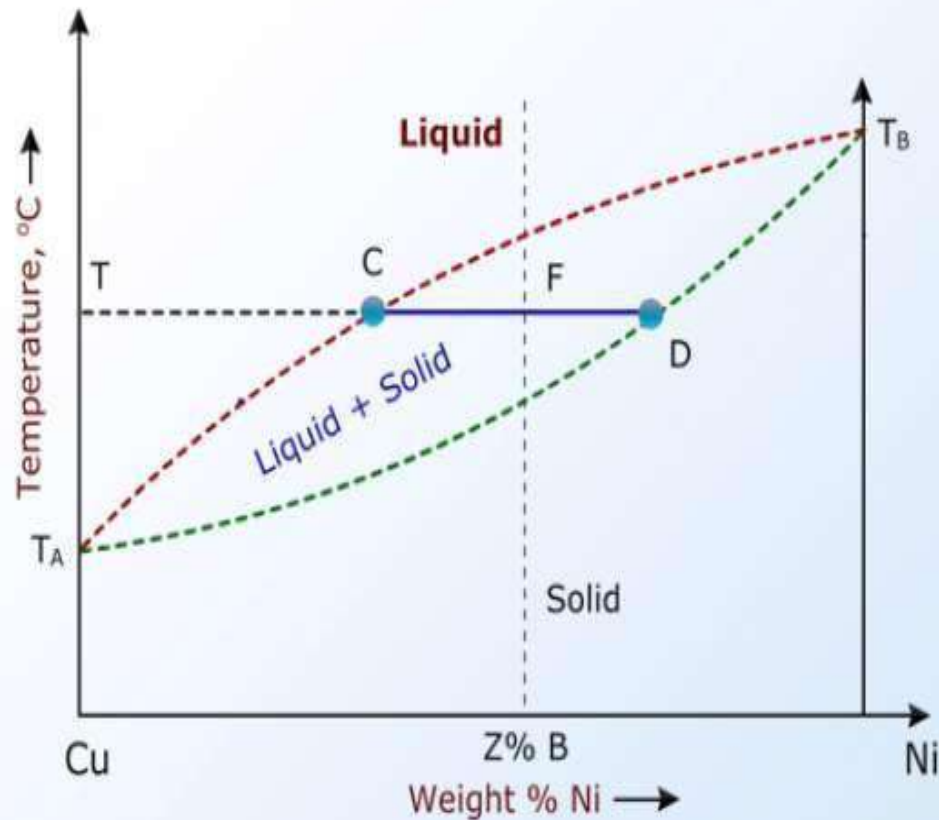

Cu-Ni Phase Diagram

Coring

- Variation in composition observed from point to point or centre to surface of a grain or dendrite (micro-segregation) in a solidified alloy at room temperature is called coring.

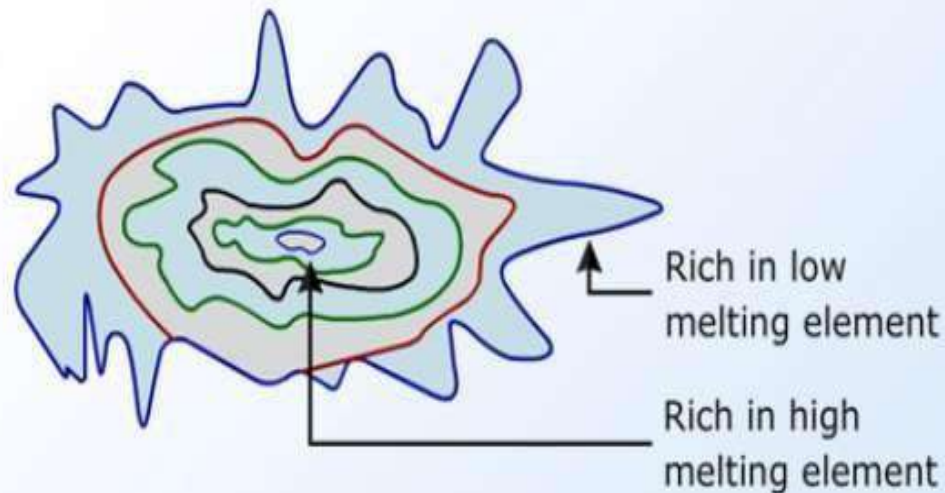

Cored dendrite

Transformation in Solid State Allotropy

Transformations in the Solid State

- There are several equilibrium changes and reactions which take place entirely in the solid state. They are known as Transformations in the Solid State.

Allotropy Change

- Allotropy is defined as the property of chemical elements to exist in two or more different forms. Allotropy change exists in dual or polycrystalline structures (based upon their temperature)

Examples are Iron, manganese, cobalt and tin

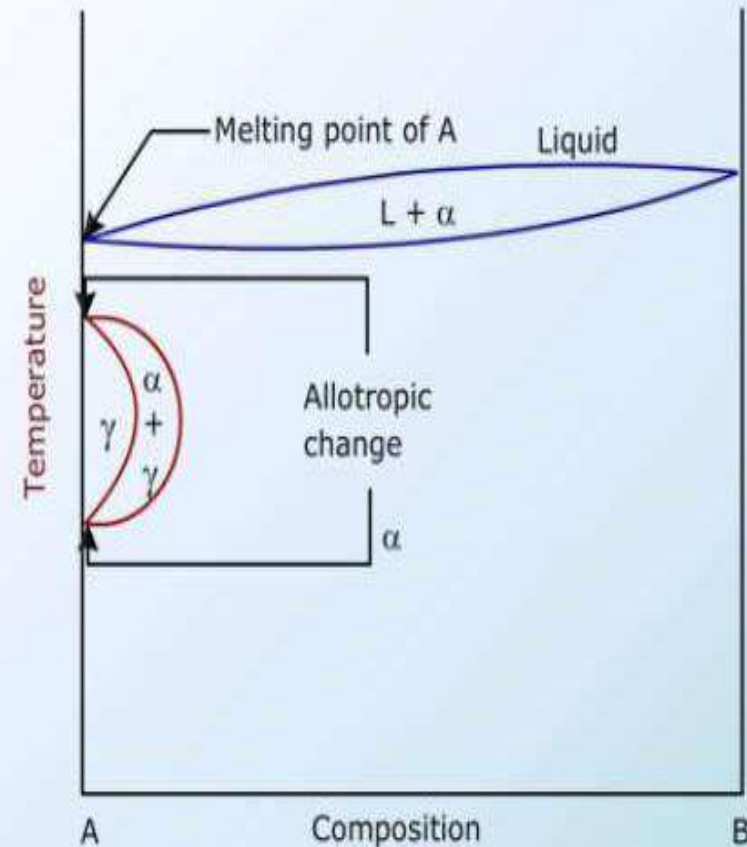

Allotropic Changes

Eutectic System

➤ Binary alloy eutectic system can be grouped as

- Two metals completely dissolve in the liquid state but does not dissolve at all in the solid state
- Two metals completely dissolve in the liquid state but partly dissolve in the solid state

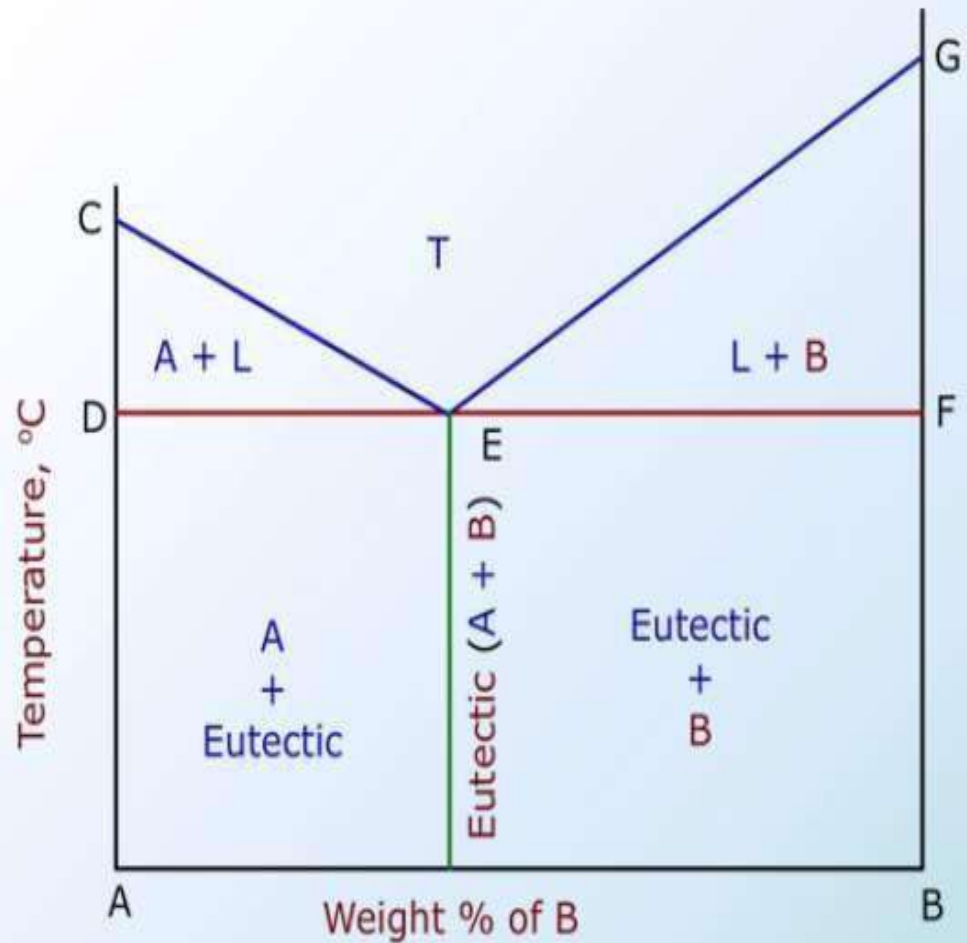

Partial Eutectic Systems

Eutectic System

- The alloy whose composition is represented by the eutectic is called eutectic alloy
- The quantitative relation between the weights of the α and β phases

$$\frac{\text{Weight of } \alpha - \text{phase}}{\text{Weight of } \beta - \text{phase}} = \frac{T' \gamma}{T' \delta}$$

Partial Eutectic Systems

- These diagrams are obtained for two metals which have complete miscibility (the property of liquids to mix in all proportions, forming a homogeneous solution) in the liquid state and partial solubility in the solid state

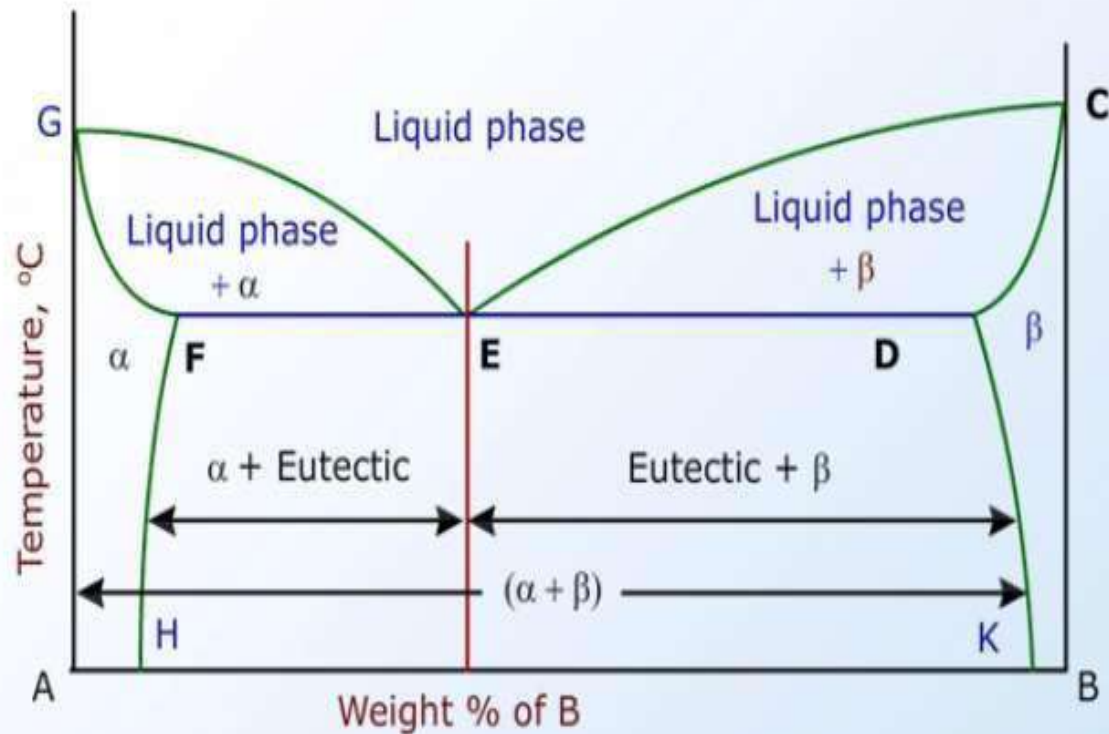

Partial Eutectic Systems

Layer Type Systems

- The binary phase diagram of a layer type system is obtained for two metals which have complete insolubility in the liquid as well as solid state

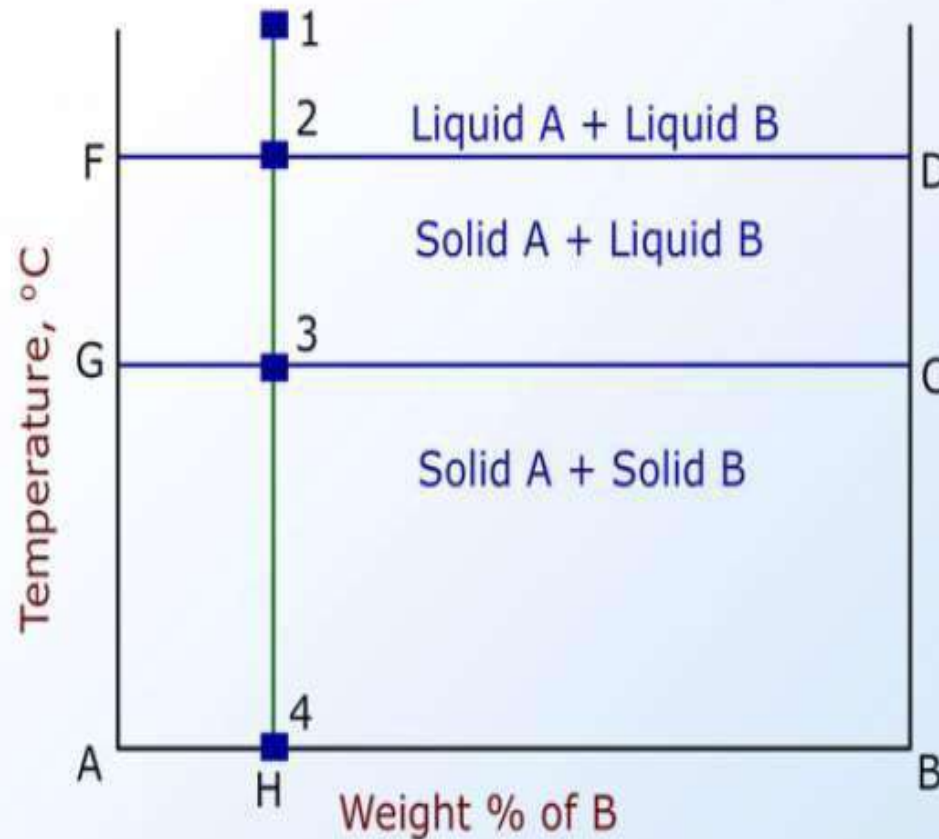

Layer Type Systems

Peritectic Transformation

- The diagram shows that the crystals of beta solid solution, precipitated at the beginning of solidification, and then they react with the liquid alloy of a definite composition to form new crystals of alpha solid solution at a constant temperature. This process is called Peritectic Transformation

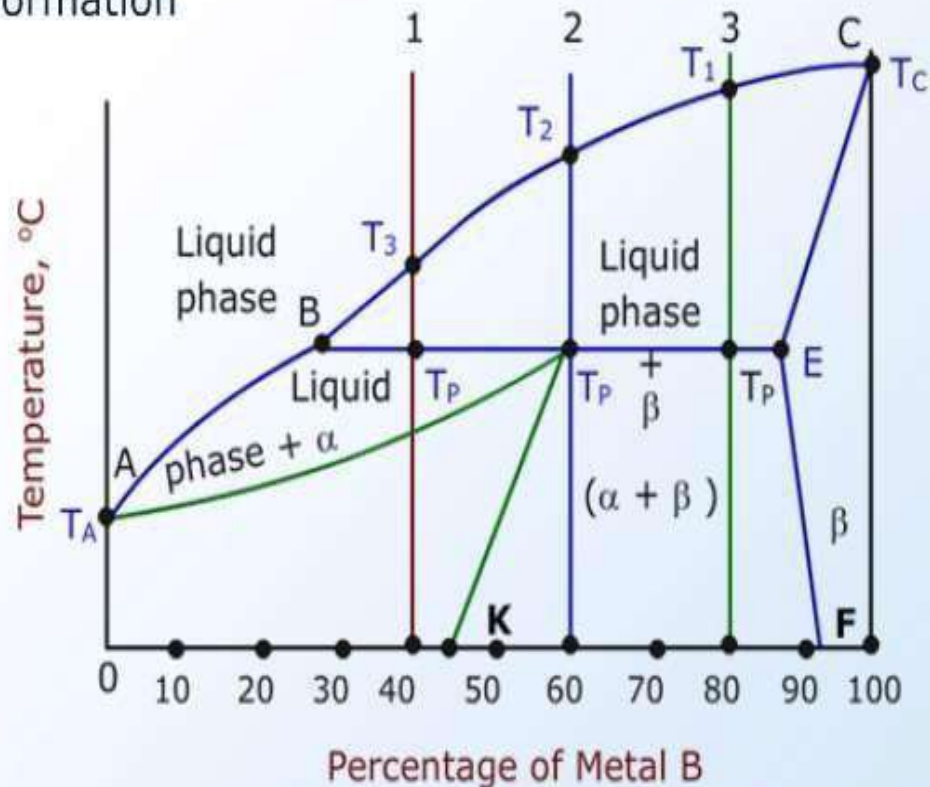

Peritectic Transformation

Phase Diagram of Aluminum and Copper

- The Cu alloy cools under equilibrium conditions
- Now, compare the composition of a solid solution in the Al-4% Cu alloy at room temperature with its composition when the alloy is quenched
- The composition of the α , determined from the tie line is about 0.02 percent copper

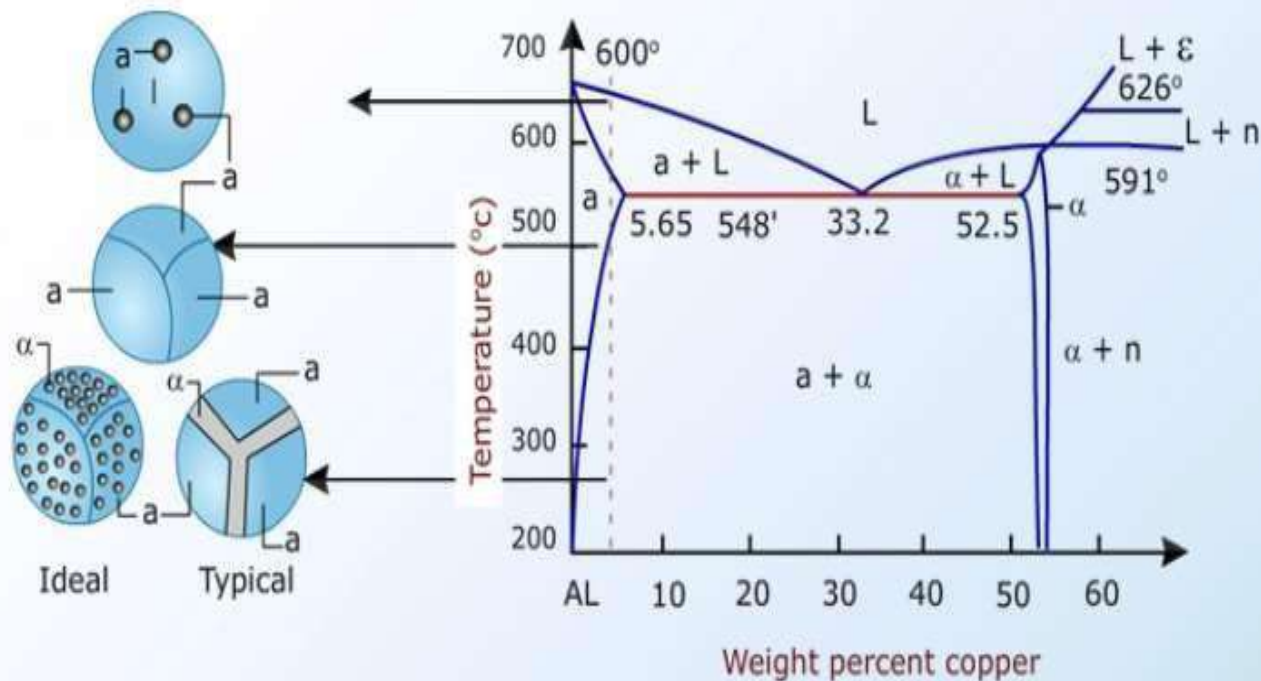

Phase Diagram of Aluminum and Copper

Copper-Zinc Binary Phase Diagram

- Cu_3Sn has been found to occur at temperatures in excess of 60°C and is generally of minor importance in the study of tin whiskers, as at these temperatures, rate effects dominated the formation of hillocks in lieu of whiskers
- The stress relaxation results in eruptions of the surface called Hillocks

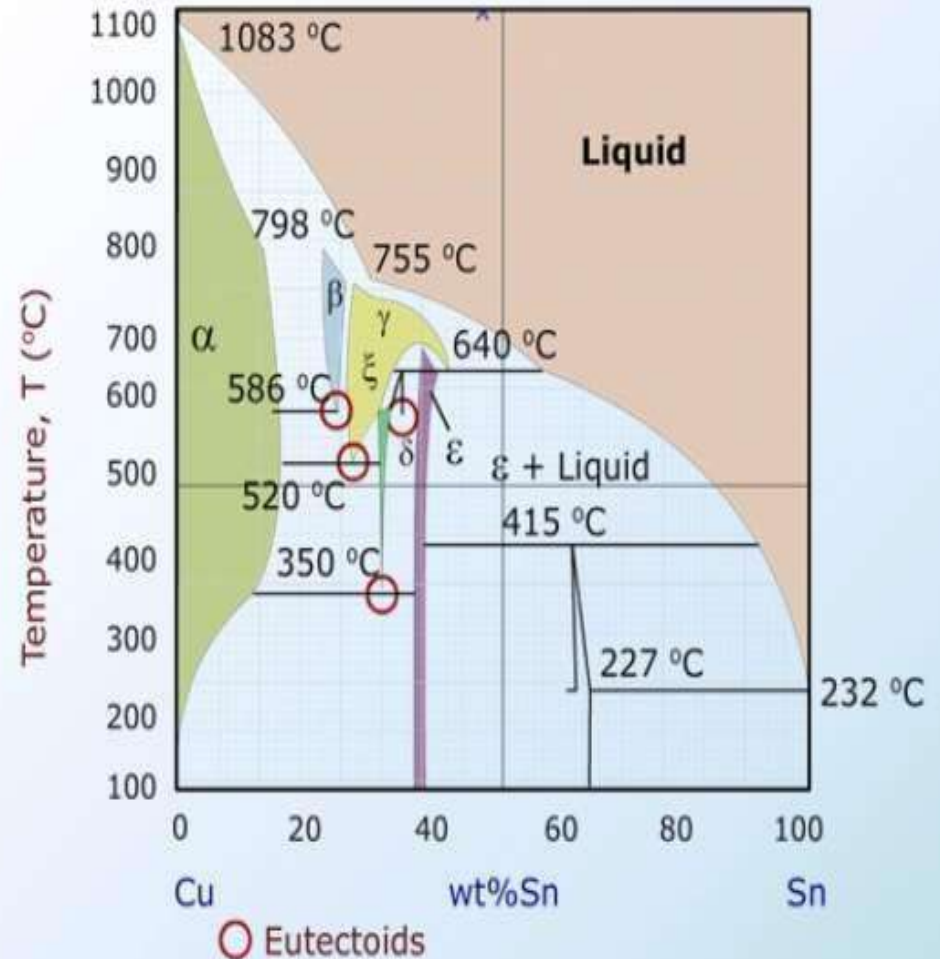

Copper-T_{in} Binary Phase Diagram

Iron-Iron Carbide (Fe-Fe₃C) Phase Diagram

Importance of Fe-Fe₃C System

- The primary structural materials in any technologically advanced culture, i.e., steels and cast irons are iron-carbon alloys
- The phase diagram of the system is the basic thing on which the relationships between heat treatment, mechanical properties, and microstructure depends

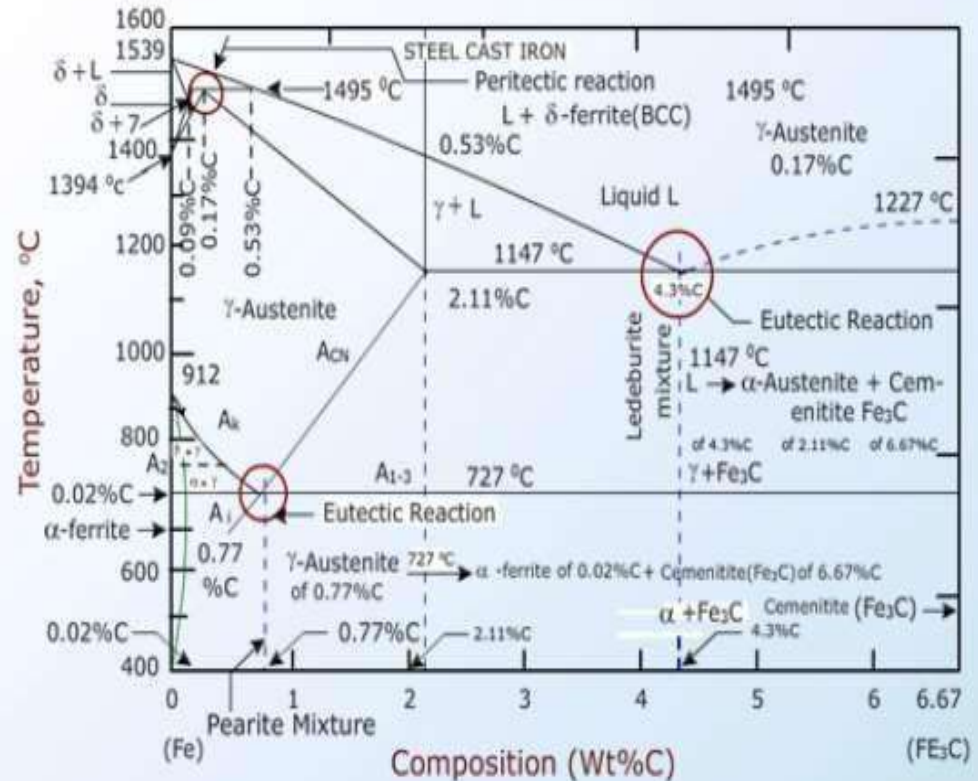

Iron-Iron Carbide (Fe-Fe₃C) Phase Diagram

UNIT-II

Steels and Cast irons

Lecture notes

Classification of materials

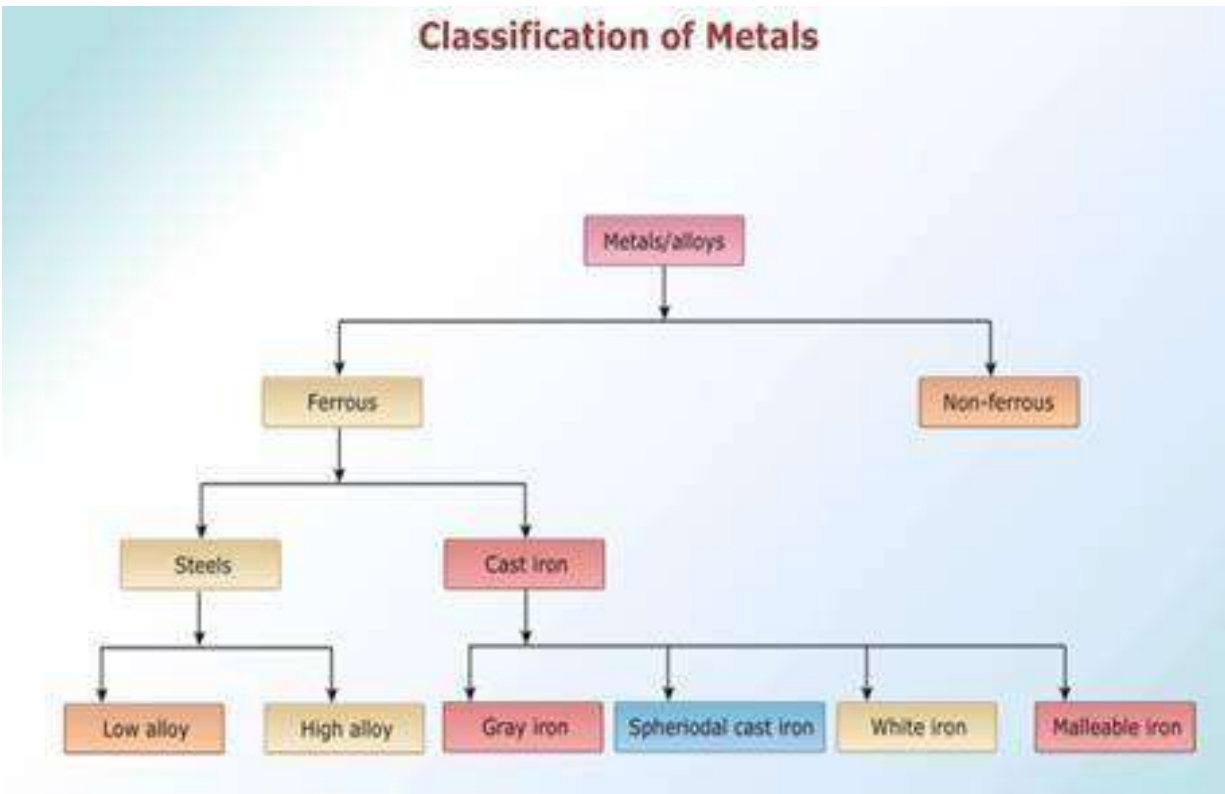

1. Cast and Its importance:-

Cast iron are basically alloys of iron and carbon like steels in which the carbon percentage varies between 2.0 to 6.67% solubility limit of carbon will be more than that in austenite and less than the carbon content of cementite. High carbon percentage makes cast iron very brittle. There four most commercially manufactured cast iron has 2.5 to 4% carbon.

Cast iron cannot be rolled drawn or worked at room temperature as cast iron has very low ductility and poor malleability. But cast iron can be readily melted and casted into complicated shapes. It can be machine to the final dimension if needed. The only suitable process applied to these alloys is casting. Hence the name given as “cast iron”.

Raw materials used in the manufacture of cast iron are cheap, hence it is the cheapest alloy among the commercial alloys. The melting temperature of cast iron is in the range of 1150-1250

C which is less when compared to the melting temperature of steel hence it is easy to melt cast iron has good corrosion resistance.

2. Advantage of steel over cast iron:-

1. Steels can be hardened and temperature.
2. Steels are tough and more elastic than cast iron.
3. Steels can be readily forged and welded compared to cast iron.
4. Steels can be permanently magnetized, where as cast iron cannot.
5. Steels are ductile.
6. Tensile strength of steel is better than cast iron.
7. Steels are not affected by salty water, where as cast iron becomes soft in salty water.

3. Heat treatment of cast iron:-

The various heat treatments given to cast iron are

1. Stress relieving.
2. Annealing.
3. Normalizing.
4. Hardening and tempering.
5. Austempering

1. Stress relieving:-

It is the type of heat treatment usually applied to cast iron in order to relieve residual stresses which may reduce strength, cause distortion and in some extreme case even result in cracking. This type of heat treatment is most frequently applied for gray cast iron by heating it to a temperature range of 500 to 550°C Cunnig remove residual stresses present.

2. Annealing:-

Annealing is a heat treatment given to cast iron in order to soften the casting and to improve their machinability and ductility. For roost gray of 850 to 900°c. to soften it and thus improve it machinability. For spheroidal graphite cast iron annealing girl done to increase in toughness and ductility.

The white cast iron has cementite structure which is very hard and brittle. So annealing heat treatment process is used to make the white cast iron soft i.e. malleable.

3. Normalizing:

This is one of the Simplest heat treatment frequently applied to casting, forging etc... To refine grain structure to relieve stresses and to increase strength and hardness. Normalizing is a process of heat treatment given to gray cast iron by heating it to a temperature above the transformation range normalizing is done by cooling it in air from 900 to 920°C temperature

4. Hardening and tempering:-

Hardening and tempering heat treatment are applied to cast iron to increase its strength, hardness and abrasion resistance. Hardening is a process of heat treatment applied for cast iron by heating it to a temperature range of 860 to 900°C, whereas tempering is the process of heat treatment applied for quenching cast iron. Tempering is of two types. Low temperature tempering having temperature range of 200 to 250°C and high temperature tempering having temperature range from 300 to 350°C. Tempering applied to cast iron improves its machinability, strength and toughness.

5. Austempering:-

It is the heat treatment process, cast iron is first heated to a temperature of 850 to 900°C and then quenched in a bath at 500 to 550°C. Generally, this is applied on the casting to increase hardness, ductility, toughness.

4. VARIOUS TYPES of CAST IRON

The types of cast iron are as follows

1 White cast iron:-

All the carbon is in combined form as cementite

2 Malleable cast iron:-

All the carbon is combined in the form of irregular sized particles called temper carbon. Heat treatment of white cast iron gives malleable cast iron

3 Gray cast iron:-

All iron carbons are uncombined in the form of graphite flakes

4 Nodular cast iron:-

By addition of special alloys the carbon is largely uncombined in the form compact spheroids

white cast iron:-

The fact that is freshly broken surface shows a bright white feature given the name as white cast iron. White cast iron has almost all iron carbon chemically bonded whether the iron as iron carbide. Iron carbide is very hard and brittle. Thus white cast iron possesses excellent abrasive white resistance under normal conditions white cast iron is brittle and not machineable

Malleable cast iron:-

Malleable cast iron can be hammered and rolled to get different shapes. Through a controlled heat treatment process from white cast iron malleable cast iron is obtained. An alloy malleable cast iron contains manganese and nickel and hence they have high strength and are corrosion resistant. Malleable cast iron possesses high yield strength low coefficient of thermal expansion low wear resistance and good vibration capacity

Grey cast iron:-

Gray cast iron is basically an alloy of carbon and silicon with iron. It is readily cast into a sand mould to get required shapes. It is marked by the presence of graphite flake in a matrix of ferrite, pearlite or austenite 10% of metal volume is occupied by the graphite flakes. Length of the flakes may vary from 0.05mm to 0.1mm, gray cast iron has low melting point among the ferrous alloy. Gray cast iron can be cast into complex shapes and thin sections due to high fluidity. It also has good machinability, high resistance to wear and also a high vibration damping capacity. Gray cast iron has an excellent casting quality for the production of simple and complex shapes

Nodular cast iron:-

Nodular cast iron is also known as ductile iron. Unlike the long flakes in the gray cast iron, graphite appears as rounded particles or nodules. The spheroidizing element when added to the melt eliminates sulphur and oxygen which change the solidification characteristics and possibly

account for nodulizing. Ductile cast iron possess shone machinability. The properties of ductile cast iron depend on the metal composition name the cooling rate. It possess good cast ability and excellent wear resistance. Nodular cast iron is mostly used in internal combustion engines.

5- Properties of white cast iron and gray cast iron:-

W.C.I:-

- 1) Due to the presence of cementite in large amount white cast iron are hard and brittle.
- 2) It has wear resistance properties
- 3) Due un high hard mess,it is not machinable

G.C.I:-

- 1 It has high vibration damping capacity.
- 2 It mechinability is better compared to w.c.i.
- 3Rigidity of G.C.I Is high.
- 4 High compressive strength.
- 5 High wear resistance properties

6- Malleabilizing treatment of white cast iron:-

White cast iron consists me cementite which is very hard and brittle so in order to make the white cast iron soft and malleable, heat treatment is carried out. Cementite egress a malleable phase which decomposes in to iron and carbon. A Very long time heat treatment at higher temperature is called mallebilizing treatment.

This treatment contests the cementite in white cast iron into irregular nodules of temper carbon and ferrite. It consists me heating the white cast iron at a temperature around 900°C for long time. This process is carried out in two stages i.e... First stage annealing and second stage annealing.

It first stage annealing, white cast iron is heated in non-oxidizing environment to temperature at 900°C. This heating contests the pearlite into austenite at lower critical temperature. The austenite thus formed dissolves some more cementite during heating.

The graphitization starts by precipitation of a graphite nucleus. Which. Grows in all direction giving irregular nodules or spheroidal shape called temper carbon formed at a interface area b/w primary carbides and saturated austenite. The rate of decomposition of primary carbide increase with increase in annealing temperature and results in production me note graphite particles per unit area. The casting is them soaked at 900°C for two or more days. This results in spherical shape of graphite in austenite by breaking down the cementite.

In second stage annealing, the casting is them cooled very slowly, resulting gin changing of austenite into ferrite and more graphite. After completion of graphitization, there is no change in structure during cooling up to room temperature and the micro structure at this stage consists of tempered carbon nodules in a ferrite matrix,

7- Malleable iron and ductile iron in terms of:-

- 1) Manufacturing process
- 2) Structure
- 3) Properties
- 4) Applications

Manufacturing process:

Malleable cast iron is produced is by heat treating white cast iron. The heat treatment involves is annealing. Two stages are annealing are involved in first stage annealing, the white cast iron is slowly heated to a temperature b/w 900c to 950c. in second stage of annealing, the obtained casting is cooled slowly.

Ductile cast iron is produced by the addition of elements like calcium, sodium and magnesium to the molten metal. it is obtained directly by solidification and does not require heat treatment.

Structure:

Micro structure of malleable cast iron contains white ferritic layer with nodules of temper carbon in ferric (or) peralite matrix and that of black heat malleable cast iron consists of white ferric layer with nodules of tempered carbon ferritic matrix.

Micro structure of ductile cast iron consist of nodules of graphite in ferritic (or) perlitic matrix.

Properties:

Malleable cast iron has good wear resistance, vibration damping capacity high yield strength good cast ability and machinability. But malleable cast iron can't be draw into wires i.e.. Ductility is very poor.

Applications:

Malleable cast iron is used in automotive industry brakes, crankshaft and cam shafts.

Ductile cast iron is used in metalworking rules, gears and sheat metal dies.

Gray cast iron:-

Properties and users why gray cost iron is brittle ,while malleable iron is not?

Properties

- 1 it has high compressive strength
- 2 It has high fluidity
- 3 high self damping capacity
- 4 High resistance to wear
- 5 good machinabilily

Users:-

- 1 gray cast iron is used in machine tool stretchers such as beds base for different types of machine tools frames etc.
- 2 Piston rings and engine frames
- 3 polling mills and general machinery parts
- 4 lower grade of gray cast iron is used for clutch plates brake drunk
- 5 water pipes

Gray cast iron is brittle due to the presence of

Graphite flakes where as in malleable cast iron

Graphite appears as spherical particles

Graphite flakes in gray cast iron is surrounded by ferrite areas

The cast irons containing graphite in the form of flakes are called gray cast iron. The graphite in these cast iron is formed during freezing. The graphite flakes interrupt the steel like matrix to a large extent most gray cast irons are hypoeutectic alloys containing between 2.5 and 4% carbon these alloys first solidify by forming primary austenite the initial appearance of combined resulting from the eutectic reaction at 2065f the cementite resulting from will graphite rapidly the graphite appears irregular generally elongated and curved plates which gives gray cast iron its characteristic gray cast iron its characteristic grayish color when fractured

During continued cooling there is additional precipitation of carbon because as of decreased solubility of carbon in austenite the carbon is precipitated as graphite which promptly graphitizes

The strength of gray cast iron depends on the matrix in which the graphite is embedded. This matrix is largely determined by the condition of eutectoid cementite also graphitizes, and then matrix will be entirely ferrite.

Since, gray cast iron is soft and ductile; the matrix will be purely ferritic.

Nodular cast iron:-

1) It is possible to make nodular iron by heat treatment

A) Nodular cast iron does not require heat treatment, they are usually obtained as a result of solidification.

Nodular cast iron are produced from gray cast iron by the addition of a small quantity of certain element called as nodulizing elements usually magnesium is added to gray cast iron melt in the ladle just prior to pouring into moulds.

These cast iron do not suffer from the defects of gray cast iron such as growth and free cracks when used at elevated temperature. Hence, gray cast irons do not need heat treatment as they are obtained from solidification.

WHY SHOULD THE SULPHUR CONTENT IS BELOW IN THE MANUFACTURE ME NODULAR IRON?

The nodulizing elements have strong affinity for sulphur and they separate with sulphur from the molten bath as an initial step in producing nodular graphite.

The addition are expensive and hence for effective utilization of there elements. The gray iron melt should contain less amount me sulphur i.e.<0.03%.

MIN THE MANUFACTURE ME NODULAR IRON WHY ARE INOCULANTS ADDED ONLY JUST BEFORE CASTING..?

The best method me reducing the size and improving the distribution me granite flakes is by the addition me small amount me material called inoculant such as aluminium, magnesium, titanium mane silicon carbide etc. and there when added night increases the nucleation rate giving rise to a find interrupt the continuity me the matrix much less than the saphite flakes Due un this s.g cast iron has a high strength and toughness when compared un the same structure of the gray iron.

The general composition me s.g cast iron is

carbon

silicon

manganese

sulphur

phosphorus

magnesium

To increase the strength and hardess of s.g cast iron nickel may be added as an allying elements

THE PROPERTIES ME S.G CAST IRON

- 1 The strength of s.g cast iron is equal un Vietnam of steel
- 2 It also has good toughness and ductility
- 3 It has superior wear resistance
- 4 It has good strength and stock resistance
- 5 This type me cast iron is more ductile and stronger than gray cast iron.

Applications:

The S.G cost vrons are widely used for 1) crank shafp, 2) valves, 3) hydraulic cylinders, 4) cylinder heads, 5) connecting rods.

A major application of this, is in marine and steam plants due to the fact S.G cost vron has good compression and corrosion resistance.

Q: Effect of sulphur, manganese, silicon, and phosphorous on the properties of plain carbon steels.

Ans:

Sulphur: a) Vmproves machinability of steels.

b) Reduces ductility and toughness.

c) Increases hardness and brittleness.

d) Addition of sulphur is limited to 0.05%.

Manganese:

a) Reduces ductility and weldability when present in high amount with high Carlon content.

b) Counteracts brittleness from sulpher.

c) Increases yield strength, tensile strength, toughness and hardness.

Silicon:

a) Increases strength, hardness and toughness without loss of ductility.

b) It is strong deoxidizer.

c) Improves oxidation resistance.

d) Increases permeability of steel.

e) Strengthens low alloy steels.

Phosphorus:

- a) it dissolves in ferrite and increases hardness and tensile.
- b) increases resistance to corrosion.
- c) improves machinability.
- d) strengthens low carbon steel

Q: AISI-SAE classification of steels.

Ans: American iron and steel institution (AISI) adopted and expanded the standardization for steel used in the automotive industry which was provided by society of automotive engineers. They identified both plain carbon and alloy steel by a four digit number. In this case first digit indicates the major alloying element the second indicate the primary alloying element and the last two digit indicate the carbon content in percentage value.

<u>AISI Number</u>	<u>Type</u>
1xxx	Carbon steel
10xx	Plain carbon
2xxx	Nickel steel
3xxx	Nickel chromium

Q: Red shortness and cold shortness.

Ans:

Red shortness: Red shortness is the fragmentation of the steel by fractures and fissures developed along the grain boundaries due to working of steel at rolling or forging temperature.

Cold shortness: Cold shortness is due to the distortion of crystal lattice by the presence of phosphorus as solid solution in ferrite which increases yield point and tensile strength.

Q:

Stainless steel: Adding a small percentage of chromium to plain carbon steels for the formation of hard carbides when dispersed as fine precipitates, they increase and hardness and reduces the critical cooling rate. To improve hardenability with a less rapid cooling martensitic structure can be obtained. The amount of chromium added is less than 2%. By adding a large amount of chromium the corrosion resistance of the steels can be improved. But the rate of corrosion resistance decreases if the amount of chromium added is more than 12%. In general there are many types of stainless steels some of them are ferritic, martensitic and austenitic.

Austenitic stainless steel: The steels that contain 16% to 26% chromium more than 6% of nickel and a less percentage of carbon (0.1%) are austenitic steels. A steel of this group has the following composition 0.5% carbon, 18% chromium and 8.5% nickel. The steels which has percentage of chromium and nickel in the ratio 18:8 as they are terminated as 18/8 stainless steels. A steel without nickel is called ferritic steel. The presence of nickel in stainless steel is to give them an austenite phase, this will be increased when the amount of nickel is increased. The increase in this austenite phase will be up to a point where the alloy becomes completely austenitic at all temperatures there steels cannot be hardened by the process of quenching.

Q: Different kinds of carbon steels give their carbon content?

Ans: Carbon steels are the alloys of iron and carbon. They are different from cast iron in percentage of carbon. These are also known as plain carbon steels and are classified depending on the carbon content.

- 1) Low carbon steels (0.008 - 0.30%)
- 2) Medium carbon steels (0.30 – 0.60%)
- 3) High carbon steels (0.60 – 2.0%)

1) Low carbon steels: (0.008 - 0.30%)

It is also called as mild steels. They can be easily rolled into steels, hence good for cold working purpose. Good for fabrication work by welding, pressing or machining. They are

machinable, weldable, soft, malleable, ductile, tough and cannot be hardened by heat treatment process.

They are again classified according to carbon percentage.

a) Dead mild steel with 0.05 – 0.15% carbon:

This is used in making steel wires, reverse pipes, screws, nails and chains. Hardness of the steel will be about 115BHN and tensile strength about 390 N/mm².

b) Mild steel with 0.15 - 0.20% carbon:

Used for making crank shaft and strips hardness of the steel is 125 BHN with a tensile strength of 420 N/mm².

c) Mild steel with 0.20 - 0.30% carbon:

It is used valves, gears, crank shaft, connecting rods, railway axles etc.. Hardness of the steel is 140 BHN and tensile strength is about 555 N/mm².

2) Medium carbon steel (0.30 - 0.60%) carbon:

They have intermediate properties. High cooling rates are needed for hardening and less hardness is obtained they are malleable not so ductile medium tough.

They are again classified according to the carbon %.

a) carbon steel with (0.20 - 0.45% carbon) :

Used for making gears, shaft connecting rods tensile strength is 750 N/mm² and hardness of the steel is 200 BHN

b) Steel with (0.45 - 0.55% carbon) :

used for making parts which are subjected to shock and heavy reversal loading .like axles crankshaft. tensile is 100 N/mm² and hardness of the steel is 300 BHN .

c) steel with (0.55 to 0.6% carbon) :

Used for making valve springs, die, blocks, clutch discs, cushion rings etc..

Tensile strength is 1230 N/mm² and hardness of the steel is 400 - 450 BHN.

3) High carbon steels (0.6 to 2.0/carbon) :

These are hardened by the heat treatment process for high hardness. Depth of hardening and hardenability depth. It cannot be cold worked.

They are classified based on the carbon percentage.

a) Steel with 0.7 – 0.8% carbon:

used for making cold chisels, wrenches, etc.. The tensile strength is 1400 N/mm² and hardness is 450 – 500 BHN.

b) Steel with 0.8 - 0.9% carbon:

used for making rock drill railway lines etc.. The tensile strength is 660N/mm² and hardness is 500 - 600 BHN.

c) Steel with 0.9 - 1.0% carbon:

Used for making punches and dies speed die the tensile strength is 580 N/mm² and hardness 550-600 BHN.

Q: Advantages of maraging steel as compared to regular stainless steel.

These special types of steel are air hardened by martensitic transformation and subsequently precipitation hardened by aging hence the name maraging steels.

- 1) These steel are capable of attaining tensile strength of upto 210kg/mm.
- 2) Has excellent fracture toughness.
- 3) Used for special application like rocket engines and engine components, injection moulds, dies, pressure vessels.
- 4) Has high strength as they are hardened and properly aged.

Q: What is high speed steel. Give the typical composition of high speed steel. Explain the part played by each of the alloying element in tool steel . explain treatment process of high speed steel.

Ans: High speed steel:

It is a highly alloyed tool steel which is used for removing metal at much higher speed. These are generally used for making metal cutting tools. High speed steels are mainly of two types i.e., tungsten base and molybdenum base high speed steels. These steels have excellent red hardness and shock resistance. From tool performance and manufacturing point of view there is little difference between the two types of high speed steel and also the properties like red hardness wear resistance toughness etc are same. The basic composition of the tungsten high speed steel is given as

Tungsten	-	18%
Chromium	-	4 - 8%
vanadium	-	1%

Generally used tungsten based high speed steel is designated as 18:4:1 ratio, indicating 18% tungsten 4% chromium and 1% vanadium is used to increase the abrasion resistance.

Effect of alloying element on tool steels:

1) TUNGSTEN:

- a) Increase red hardness.
- b) Promotes strength at higher temperature.
- c) Resist heat.
- d) promotes fine grains.

2) chromium:

- a) increase hardnability.
- b) increases abrasion and wear temperatures.
- c) increases strength at high temperature.
- d) increase corrosion and oxidation resistance.

3) Vanadium:

- a) increase hardnability.

- b) increases abrasion resistance to great extent.
- c) promote fine grains.
- d) impact strength and toughness.

In a typical heat treatment process of high speed steel, it is austenized at 1270°C, salt quenched to 600°C air cooled and double tempered at 525°C. As the constituents like W, Mo, Cr, V are carbide formers, the micro structure consists of carbide in the matrix of tempered martensite. This gives the contribution of wear resistant carbides in heat resisting matrix. They are widely used for lathe, planer and sharper tools etc..

Q: Alloying elements that dissolve in ferrite increases its strength?

Ans: Basically alloying elements are added to seek to increase hardenability, strength, toughness and other mechanical properties. Most of the alloying elements are soluble in ferrite to some extent and forms solid solution when added to steel. Solid solutions are harder and stronger than pure metals and hence these elements increase strength and hardness of ferrite. Thus copper, cobalt, nickel, aluminium and silicon are all found largely dissolved in ferrite. The order of increase in strength is based on the equal addition of the elements by weight. The hardening effect of these alloying elements is actually small and hence contributes less to the overall strength of the steel.

Q: What effect would the addition of 1% chromium have on properties of steel?

Ans:

Chromium is considered to be a less expensive element than nickel and forms two carbides. These carbides have high hardness and good wear resistance.

If 1% chromium is added to low carbon steel it tends to go into the solution thus increasing the strength and toughness of the ferrite.

If 1% chromium is added to high carbon steel, the hardness and wear resistance of the steel increases.

Q: Compare the properties of plain carbon steels with those of alloy steel?

Ans:

A plain carbon steel is an alloy of iron and carbon these are different from the cast irons in regard of the carbon percentage. Plain carbon steel contain carbon in the range of 0% to 1.5%. They are used at atmospheric and ordinary temperatures that are not corrosive. The strength that can be obtained expect in thin sections is relatively less hardened. The carbons have a wide range of applications it ranges from a massive. I beam to good quality tool bit used in workshops.

Compared with alloy steel carbon steels have some disadvantages like lower hardenability, in heat treatment conditions plain carbon steel exhibit a poor combination of properties. Also the plain carbon steel have limited which a

- 1) Good ductility and toughness. High strength cannot be obtained.
- 2) Uniform hardening cannot be obtained in large section.
- 3) At high temperatures the plain carbons have poor resistance to corrosion and oxidation.
- 4) The strength and hardness of the plain carbon steel are poor at high temperatures.

So, to improve the above disadvantages of plain carbons steel, some elements other than carbon are added. Though in plain carbon steel these elements are present (manganese upto 0.90% silicon up to 0.30%) but in less amount and they are used as oxidizer. Other elements that may be added to steel are nickel, chromium tungsten, molybdenum, vanadium, coppers and cobalt. Due to presence of these element alloy steels posses the following properties.

- 1) High toughness, strength and hardness.
- 2) High corrosion and oxidation resistance.
- 3) They posses high hardness and strength at high temperature.
- 4) Improved magnetic and electric properties.

The amount of manganese in this alloy steel is 1.65% and that of silicon is 0.60% when these element are mixed in steel they are called alloy steels.

Q: Short notes on die steel and tools?

Ans:

Tool and die steel are special type of steel which are used for changing the shape of the material into a finished or semi-finished product, by forming or cutting. During hardening, they change in form possess good wear resistance, toughness, machinability, and softening.

Die steel, Should be heated slowly and uniformly, protective furnace atmosphere

UNIT-III

Heat Treatment of Steels

Lecture notes

HEAT TREATMENT OF STEELS:

Heat treatment may be defined as an operation or combination of operations involving heating and cooling of metals and alloys in solid state to obtain desirable conditions or properties.

Or

Heat treatment can be defined as heating and cooling operation applied to metals and alloys in solid state so as to obtain desired properties.

PURPOSE OF HEAT TREATMENT:

1. Relieving internal stress developing during cold working, welding, casting and forging.
2. To improve ductility and toughness.
3. Grain refinement.
4. Improve machinability.
5. Inc. hardness or tensile strength and achieving changes in chemical composition of

DEPT OF MECHANICAL ENGINEERING
metals surfaces as in case of case hardening.

6. Improve electric and magnetic properties.

7. Inc. heat, wear and corrosion resistance of materials.

Heat treatment process variables/stages..

1. Temp. Up to which the metal/alloy is heated.
2. The length of time. The metal/alloy is held at that temp. i.e. holding time.
3. Rate of cooling: the atmosphere surrounding the metal alloy when it is heated.

Classification of heat treatment of stress:**1. Annealing:**

- Stress relief annealing
- Process annealing
- Spherodizing annealing
- Full annealing.

2. Normalizing
3. Hardening
4. Tempering
5. Austempering
6. Martempering
7. Case hardening or surface hardening

ANNEALING:

This consists of heating the steel to a certain predetermined temp. Holding it at that temp. for sufficient time to allow the necessary changes to occur and then cooling slowly at a predetermined rate.

PURPOSE OF ANNEALING:

1. To relieve internal stress induced by previous treatment/operational such as rolling, casting, forging etc.
2. To improve machinability.
3. To soften the stress.
4. To refine and homogenize structure.
5. To induce stable structure.
6. To improve mechanical, physical, electrical, and magnetic properties.

STRESS RELIEF ANNEALING:

Stress relieving annealing relieves the internal stress induced by cold working, casting, welding etc.

In this process the cold working steel is heated to a temp. Between 500⁰c to 550⁰c usually below its recrystallization temp. (0.3 to 0.4 mp) heated to this temp. In air. Due to this the internal stress are relieved without changes in microstructure. If the stress are not relieving they might later cause warpage or even failure of the part.

Stress relief annealing is suited for ferrous and non ferrous metals.

PROCESS ANNEALING:

This is used in sheet and wire drawing industries to remove the effects of cold work this heat treatment is applied after cold work to soften the steel by reccrystalization and to permit further cold work.

In this process the cold working steel is heated above its reccrystalization temp. 600°C i.e. below the lower critical temperature line A_1 .

SPHEROID ZING ANNEALING:

The hyper eutectoid steel is consisting of pearlite and cementite network will have poor machinability. Because the cutting tool can't penetrate through the hard and brittle cementite plates.

Spheroidize annealing produces spheroidal or globular form of cementite from plates of cementite .so that the machinablity will be the improved.

Methods of follow produce spherodized structure:

- a) Heating steel and its proloned holding at a temp. just below the lower critical temp A_1 .
- b) Heating and cooling alternatively between temp. that are just above and just below the lower critical temp. line A_1 .
- c) Heating to a temp. above lower critical temp. kine A_1 and then either then cooling very slowly in the furnace or holding at a atemp. Just below the lower critical temp.

FULL ANNEALING:

The purpose of full annealing is

- a) To refine grains
- b) To induce softness
- c) To improve machinablity
- d) To improve electrical and magnetic properties.

In this process hypo eutectoid steels are heated above A_3 and hyper eutectoid steels are heated above A_1 by $30\text{ }^{\circ}\text{C}$ to $50\text{ }^{\circ}\text{C}$ held at this temp. For a definite period (2.5-3 min per 1mm thickness) and then cool slowly in the furnace itself. Depending on the composition, hyper eutectoid steels are always annealed from above A_1 temp. And not from above ACM temp. because

- a) If annealed from above ACM temp. Brittleness is induced.
- b) Above ACM temp grain coarsing of austenite occurs.

NORMALIZING:

Normalizing or air quenching consist of in heating stress to above $40\text{ }^{\circ}\text{C}$ to $50\text{ }^{\circ}\text{C}$ above its upper critical temp. (A_3 , ACM lines), and if necessary holding it at that temp. for short time and then cooling it still air temp.

Normalizing differs from full annealing is that the rate of cooling is more rapid and there is no extended soaking period.

PURPOSE OF NORMALIZING:

1. Produces uniform structures
2. Refine the grain size of steel
3. Reduces internal stress
4. Improves structural in weld
5. Produces harder and stronger steel than full annealing

HARDENING:

It is the heat of steels which inc. its hardness by quenching.

PURPOSE OF HARDENING:

1. To inc. the hardness of steels and tool steel.
2. To improve the wear resistance of steels.
3. To improve magnetic properties

Note: plain carbon steels are quenched hardened by water and alloy steels are quenched / hardened by oil

0.3 – 0.5 % C steels are hardened by hardening operation in this process the hypo eutectoid steels are heated above the lower critical temp. by 30-50 °C held at that temp. Sufficient time and then quenched (rapidly cooled) in water or oil or brine solution. Due to this the austenite changes instantaneously into martensite.

Martensite is the super saturated solid sol. Of carbon in the α -iron, which is very hard and brittle and this imparts high hardness to steels after hardening treatment.

TYPES OF QUENCHING MEDIUM:

Some of the industrial quenching medium in order of decreasing quenching severity.

- I. 5 – 10 % caustic soda – very drastic quenching
- II. 5 – 20 % NaCl
- III. Cold water
- IV. Warm water.
- V. Mineral oil
- VI. Animal oils
- VII. Vegetable oil
- VIII. Air-least drastic quenching

TEMPERING :

Hardening of steel by quenching produces micro structure consists of martensite and retained austenite. The martensite formed during quenching is highly brittle and stressed.

The hardened steel is not used in this condition because cracking and distortion occurs. And also retained austenite is an unstable phase and the dimensions of the object may be changed with time.

Hardening is always followed by tempering.

Definition:

Tempering consist of heated the hardened components below the lower critical temperature. Hold at that temperature for sufficient period and then cooling to room temperature usually in air (water, oil)

CLASSIFICATION OF TEMPERING:

- i. Low temperature tempering
- ii. Medium temperature tempering
- iii. High temperature tempering

I: LOW TEMPERATURE TEMPERING:

1. This treatment is carried out in the temperature range 150⁰c-250⁰
2. internal stress are relieved
3. the structure still contains martensite
4. L.TT is applied to cutting tools of carbon steels and low alloy steels.

2.MEDIUM TEMPERATURE TEMPERING:

1. It is carried out from the range 350⁰-450⁰c
2. This treatment develops troosite structures
3. Is applied to objects such as coil springs, laminate springs hammer chisels.

iii. **HIGH TEMPERATURE TEMPERING :**

1. It is carried out in the temperature range 550⁰-650⁰c
2. It eliminates stress completely
3. It develops sorbite structures
4. Used for components such as connecting rods, shafts

AUS TEMPERING:

Austempering is the cooling of austenite steel with a rate more than critical cooling rate in molten salt bath held at temperature between the nose of the TTT diagram and MS temperature that is in the bainite region the component held at that temperature for a sufficient period of time till the entire structure in the component completely transformed to bainite. It then

cooled in air at any desired rate to room temperature at the end of aus tempering a bainite structure obtained further heat treatment by tempering is not necessary

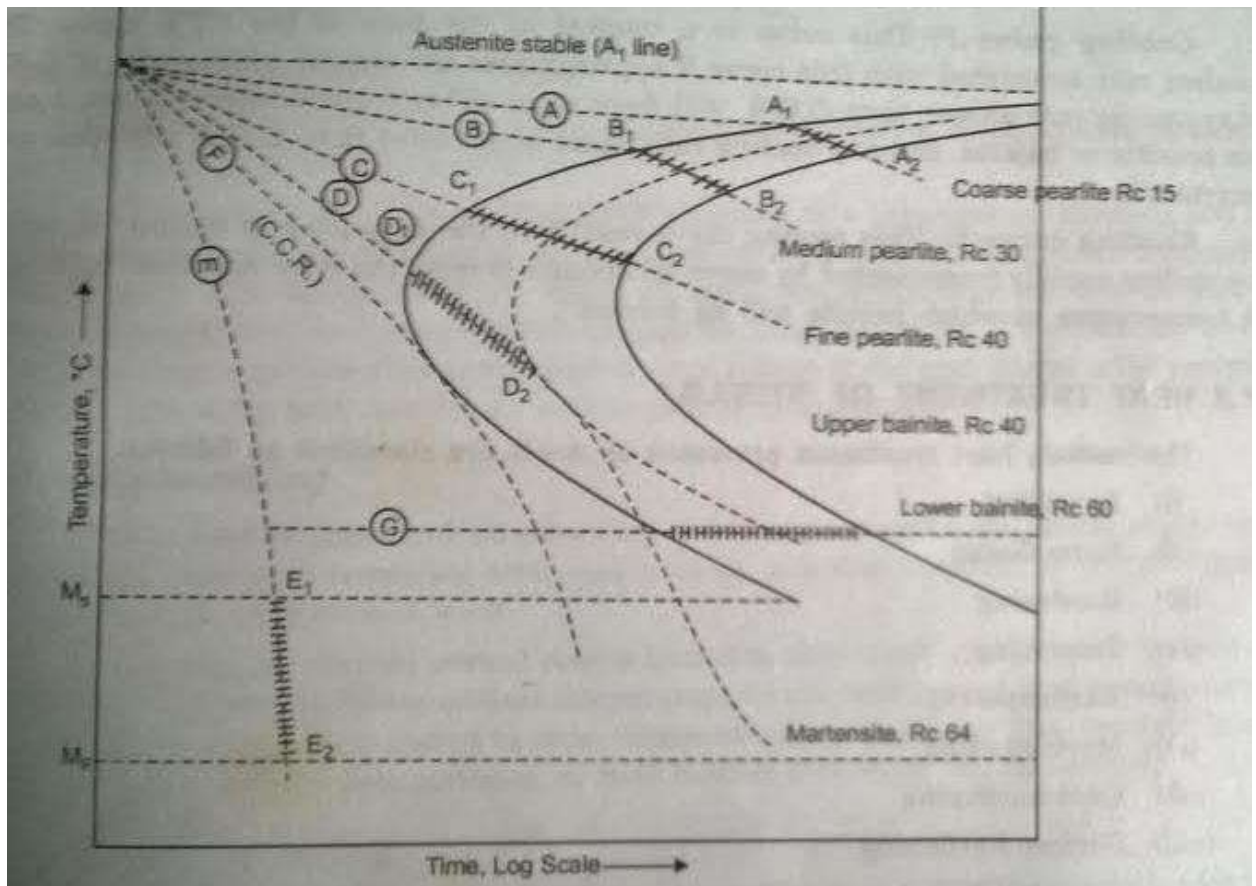

ADVANTAGES OF AUSTEMPEARING:

1. The final structure and properties are similar to the tempered martensite obtained during tempering without cooling curves going through the martensite region.
2. There is no formation of retained austenite in this structure and there is more dimensional stable of the component

DIS ADVANTAGES OF AUSTEMPEARING:

1. The hardness obtained is not as high as the obtained through martensite transformation as in hardness
2. This soaking time for the transformations place is more hence this is a more expensive process.

MARTEMPEARING:

Martempering is a hardening process. Mar tempering involves heating steel to above the austenizing temperature and then quenching in to the salt bath maintain at a temperature above Ms point (250⁰c).the steel is held in the bath till the temperature throughout the section.

ADVANTAGES OF MARTEMPEARING:

1. There is less distortion and warping since in the formation of martensite the same time throughout cross section.
2. Possibility of quench cracks is less.

SURFACE HARDENING (OR) CASE HARDENING:

Hard and wear resistance surface is called case (or) surface,soft,tough and shock resistance inside the material is called core.

Eg:cams,gears.

METHODES FOR CASE HARDENING:

METHODS THE COMPONENT IS HEATED

1. Carbonizing
2. Nitriding
3. Cyaniding
4. Carbonitrading

METHODS ONLY THE SURFACE OF THE COMPONENT IS HEATED

6. Flame hardening.
7. Induction hardening.

CARBORISING:

It is a method of introducing carbon in to a solid iron base alloys such as low carbon steels in order to produce hard case.

CHARACTERISTICS:

1. Case depth is about 0.05 inch
2. Hardness after heat treatment RC65
3. Carburizing causes negligible changes in dimensions
4. Distortion occurs during heat treatment

USES: Gears, camshafts.....etc

TYPES OF CARBURIZING: Three types:

- i. Pack carburising(solid)
- ii. Liquid carburising
- iii. Gas carburising

i. **Pack carburizing(solid):**

The box is steel box of cast iron.distance between pieces 500mm.energized material is 40% of $\text{Na}_2\text{CO}_3 + \text{BaCO}_3$.

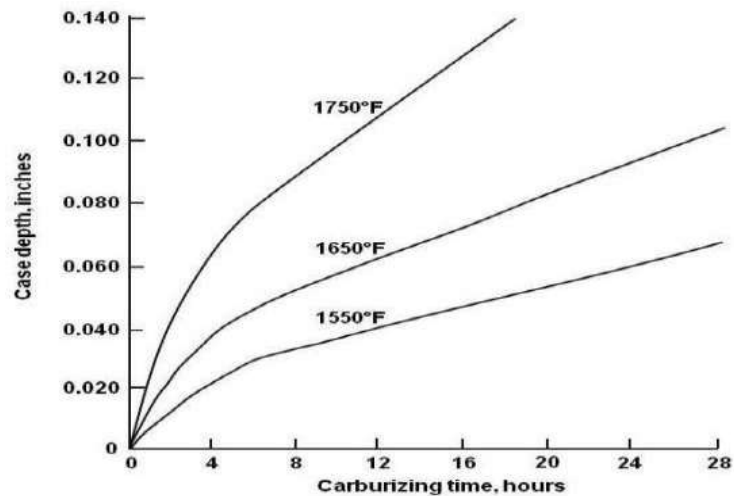

Relation of Time and Temperature to Case Depth

Holding time – 5 hours

Temperature – 900°C – 950°C

The carburising process involves the following stages

- i) Formation of “CO” in the containing carburising material when heated b/w 900 – 950⁰c
- ii) Dissociation of “CO” with the evaluation of atomic carbon



- iii) End richment of steel surface layers with carbon

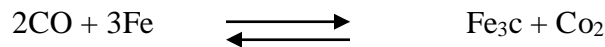

- iv) Diffusion of carbon absorbed by the steel surface, deep in the metal. The rate of diffusion of carbon in austenite at a given temp is depend up on the diffusion co-efficient and the carbon concentration. At high temp the diffusion is more
- v) It is desired to prevent any area of component from being carburised that area.
 - a) May be electroplated with “cu” to a thickness of 0.075 to 0.1 mm because is in soluble in copper at a carburising temp

LIQUID CARBURISING:

It is a carried out in molten salt bath containing 20-50% NaCN, together with up to 40% Na₂CO₃ and varying amounts of sodium (or) barium chloride. This cyanide mixture is heated to a temp of about 870-950⁰c and work piece contained in wire baskets are immersed in the liquid salt bath for periods varying from 5min to 1 hour depending upon the case depth required. The reaction occupied in cynide bath is

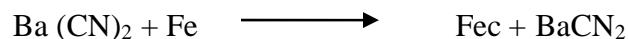
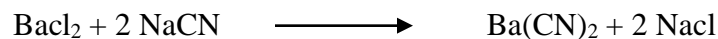

In this process “N” is also diffuse through the oxidization of sodium cyanide.

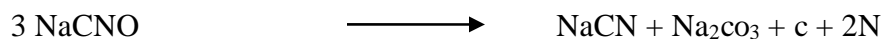
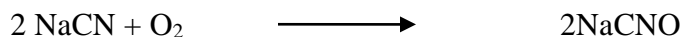

Cyanide:-

In cyaniding case is higher in N and lower in C and in liquid carburising the C is more and less N.

- Cyanide cases are seldom (or) rarely to a depth of greater than 0.25 mm, liquid carburising permits cases as deep 0.25 mm.

Advantages:-

- Rapid heat transfer
- Low distortion
- Negligible surface oxidization
- Rapid absorption of carbon & nitrogen
- Uniform case depth, and carbon content
- Reduce time to reach the carburising temp

Dis advantages:-

- Cyanide salts are highly poisonous when taken internally (or) when contact with open wounds.
- Parts need through washing after treatment to prevent rusting.

Gas carburising:-

Definition:- In carburising the components are heated at about 900⁰c for 3 (or) 4 hours in an atmosphere containing gases which will deposit 'C' atoms at the surface of the components.

Carrier gas consist of a mixture of 20% CO, 40% N₂, and 40% H₂

During carburising the following reactions will occur:

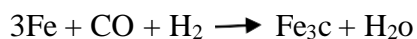
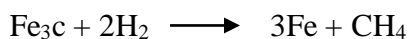

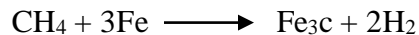
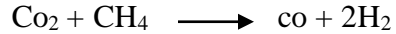

- Gas carburising can be applied in mass production
- The depth of case may vary from 0.25 mm on articles for light work.
- 0.5-1 for Automobile work.
- 0.37 mm for roller bearings and ball races where compression stresses are high

Advantages:-

- 1) Labor costs are lower than pack carburising
- 2) Floor space required is less
- 3) Less time is required
- 4) Heating is more rapid

Dis advantages:-

- 1) As compared to pack carburising higher skilled persons are required to maintain necessary controlled.

Nitriding:- It is the process of producing the hardest case (or) surface layer on medium – carbon steel only. It consists of heating the steel in a chamber with ammonia gas circulating at a temp range 500 to 600⁰c. Work piece should not be overheated, as the hardness vanishes on over-heating. No quenching medium is required

The chemical reaction is

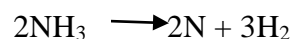

Applications: air craft engine parts, gears, clutches, valve parts, Inspection gauges etc.

Advantages:

1. Good corrosion and wear resistance
2. Good fatigue resistance
3. No machining is required after nit riding

4. The process is economical

Dis advantages:

1. Long cycle time
2. High cost of nitriding process
3. Technical control required

Process characteristics:

1. Case depth is about 0.381 mm
2. Extreme hardness (1150VHN)

Cyaniding:

In cyaniding 'C' and 'N' are introduced in to the surface of the steels by heating it to a suitable temp and holding it contact with molten cynite to form a thin skin or case. Which is sub sequent quenching hardened.

In this process the components are immersed in a liquid bath of 30% NaCN, 40% Na₂CO₃, 30% NaCl maintained at a temp of 800⁰c-850⁰c for a period of 30 minutes – 3 hours.

NaCN reacts with o₂ of air and is oxidised. The basic reaction in the bath is

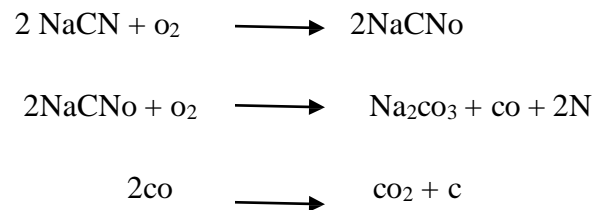

Characteristics of the process:

1. Case depth is about 0.25 mm
2. Hardness is about Rc 65
3. Distortion may occur during heat treatment

Uses: screws, nuts, bolts, small gears, plain carbon steels.

Carbonitriding:

Carbonitriding is carried out by heating the components in the temp range 800-870⁰c for about 3-4 hours in a gaseous mixture consisting of carburising gases and ammonia. A typical gases mixture contains about 15% NH₃, 5% CH₄, 80% carrier gas.

“Carbonitriding” is a modification of gas carburising process

Process characteristics:

1. Case depth is about 0.5 mm
2. Hardness after heat treatment RC 65
3. Negligible dimensional change
4. Distortion is less

Uses: Gears, bolts, nuts.

Flame hardening: In this process heat is applied to the surface of the workpiece by means of an oxy-acetylene flame. Temperature of the flame is 750 – 950⁰c.

Uses: Large parts like, lathe beds, and large gears, cams, piston pins, shafts etc.

Induction hardening: This method is similar to flame hardening in principle.

Induction hardening is applied mainly to “medium carbon steels”. In this process, heating is accomplished through the use of primary inductor coils placed around the surface to be hardened as a high frequency A.C of about 2000 to 500000 cps passes through the inductor coils.

Advantages:

1. fast operation
2. No manual handling of hot parts.

Uses: Long lead screws, tractor links, camshafts, crank shafts, and pump shafts.

Hardenability

Hardness is a measure of resistance to plastic deformation (by indentation)

Hardenability is in which the hardness may be attained in the depth direction of the object.

(Or)

Hardenability is the ability of steel to become uniformly hard (or) to harden in depth direction.

Factors effecting harden ability:

Jomminy test:

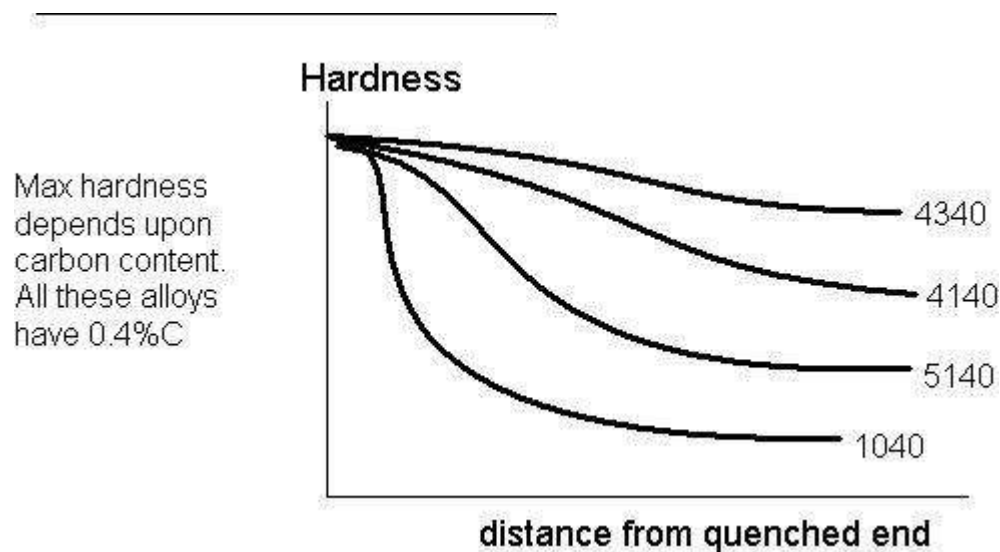

1. The composition of steel and method of manufacturing
2. The quenching media and method of quenching
3. Section of steel
4. All alloying elements excepts 'CO' tends to increase hardenabilty.
5. As compared to carbon steels alloy steels hardened to considerable large due to high stability & corresponding

Methods to determine Hardenability:

1. Grossmann method
- 2. Jominy test (end quench hardenability test):**
 1. A 25 mm diameter by 100 mm long bar is properly Austenitised as quench on the end of standardized way
 2. Heat is removed substantially from the quenched end surface and is thus withdrawn at different rate along the bar.

Age Hardening:

1. The strengthening of alloy resulting from the precipitation of finely dispersed second phase from a super saturated solid solution. The finely dispersed second phase dispersed precipitates with age i.e with the passage of time.
2. Certain alloys such as Al-4.5% Cu, Al-6%Zn etc. Shows increase in hardness with age (time) at room temp. After heating to slightly higher. This type of hardening is known as age hardening (or) precipitation hardening.

Requirements for age hardening:

1. The primary requirement of age hardening is that the solubility decreases with decreasing temp; so that a super saturated solid solution may be obtained.
2. With time the ppt that separates out from the matrix should be coherent.
Ex: in Al-4.5 % Cu. The second phase with time is CuAl_2

Age hardening procedure:

It requires the following procedure.

- i) **Heating:** The alloys first solutionised by heating it in to a single phase region.
- ii) **Quenching:** after solutionising the alloys rapidly quenched in to the two phase region. The rapidity of quench prevents the formation of equilibrium precipitate and thus produces a super saturated solid solution. The quenching media is usually water.
- iii) **Aging:** On aging at or above room temp, fine scale transition structure as small as 100°A units form.

Age hardening mechanism:

1. The essential requirement for precipitation to occur in solid solution is the decreasing solubility of solute with decreasing temp.
2. This results in a super saturated solid solution being unstable, tends to decompose according to the relation.

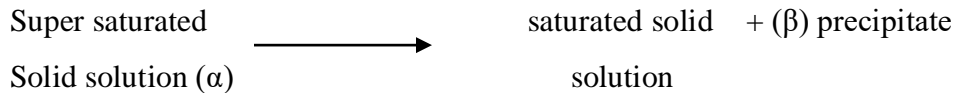

There are two distinct coherent phases α and β ,

A limited no. Of solute atoms will provide a greatest interference to dislocation moments.

The alloy exist as a single ' α ' solid solution at a temp of 548°C when it is cooled to room temp it exist as a mixture of $\alpha + \theta$, where ' α ' is a solid solution of Al with a very small percentage of (Cu 0.52) and θ is an intermetallic composed (CuAl₂) that has 52% Cu under slow cooling from 548°C To room temp the following transformation occurs.

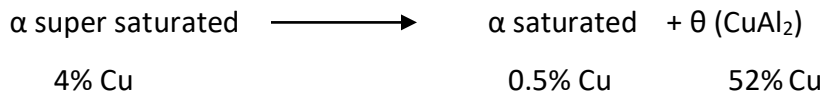

Natural aging:

Precipitation with time at room temp is called "natural aging"

Artificial aging:- Precipitation at high temp is called "Artificial Aging"

EFFECT OF ALLOYING ELEMENTS ON Fe-Fe₃C:

1. Austenite Stabilizer:

Mn, Cu, Ni are Austenite stabilizer elements. These elements are having FCC structure.

These elements raise the ' A_u ' temperature and lower the ' A_3 ' temperature, as a result of which their temperature range in which austenite exist as a stable element is increased. By

adding more alloying elements that stabilize and the stable austenite can be obtained even at room temp

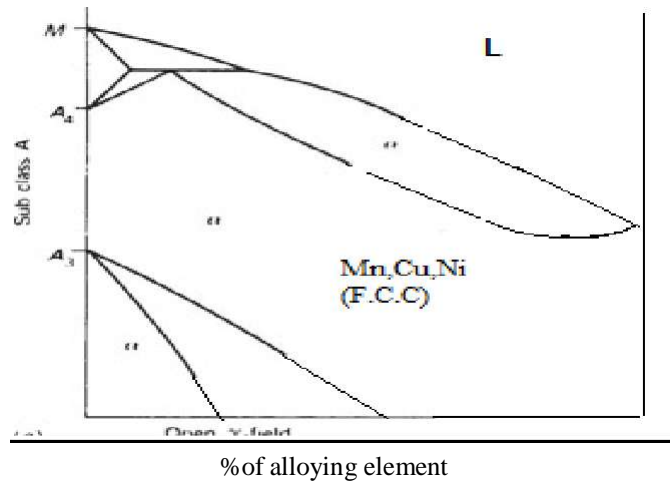

2. Ferrite stabilizer:

W, Cr, MO, V are the ferrite stabilizer elements. These elements are having BCC structure

These elements lower A_4 temperature raises A_3 increases there by increasing the range of stability of Ferrite. At certain composition the lines A_4 and A_3 merge to form a closed loop γ and above this ferrite exist from room temperature to the melting point and the austenite phase does not exist steels obtained by stabilizing Ferrite are called Ferrite steels.

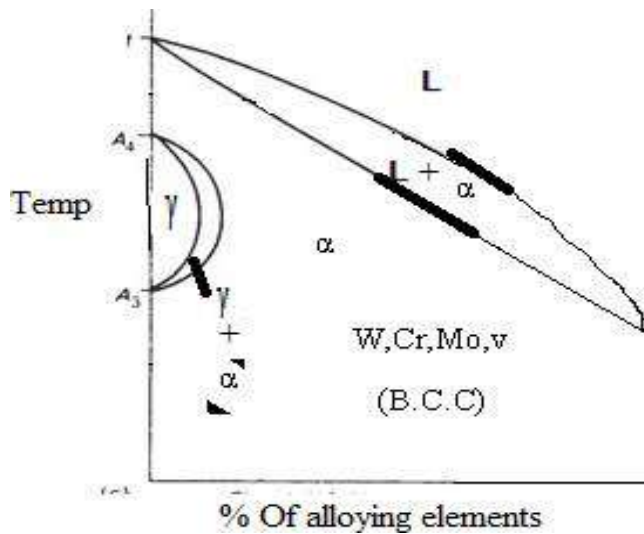

TTT DIAGRAM (TIME- TEMPERATURE- TRANSFORMATION)

(TIME- TEMPERATURE- TRANSFORMATION)

(OR)

c- Curve (OR) s- Curve (OR) BAILS CURVE (OR) ISOTHERMAL FORMATION CURVE

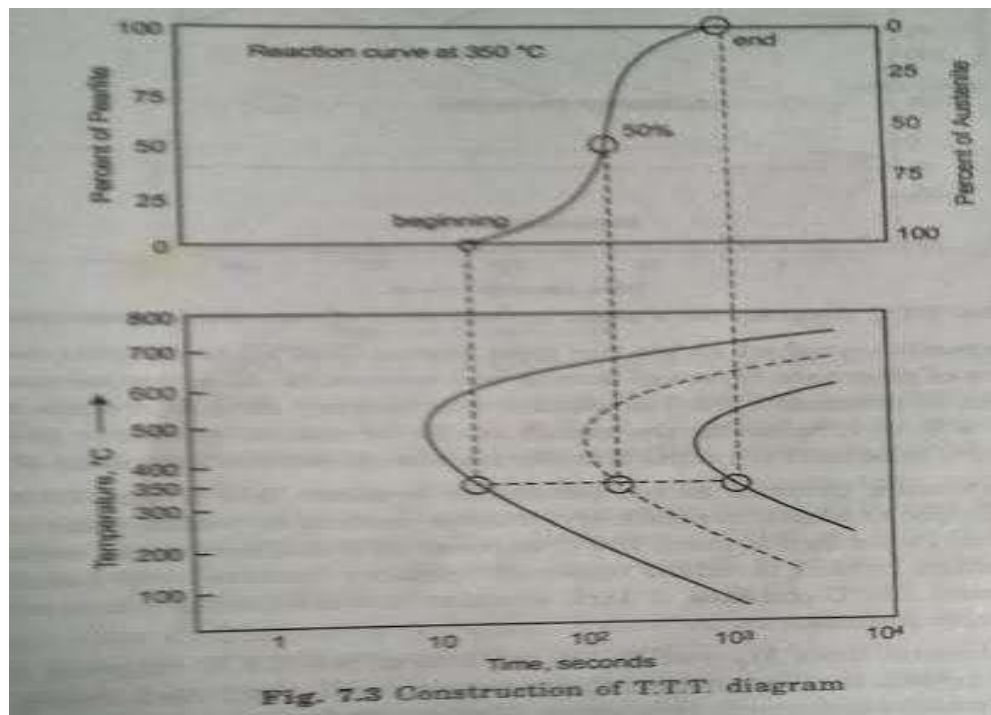
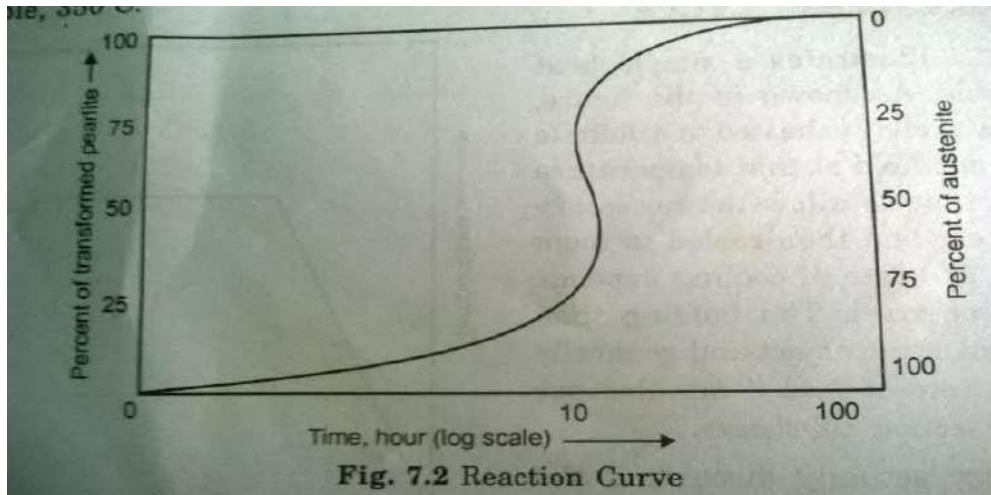

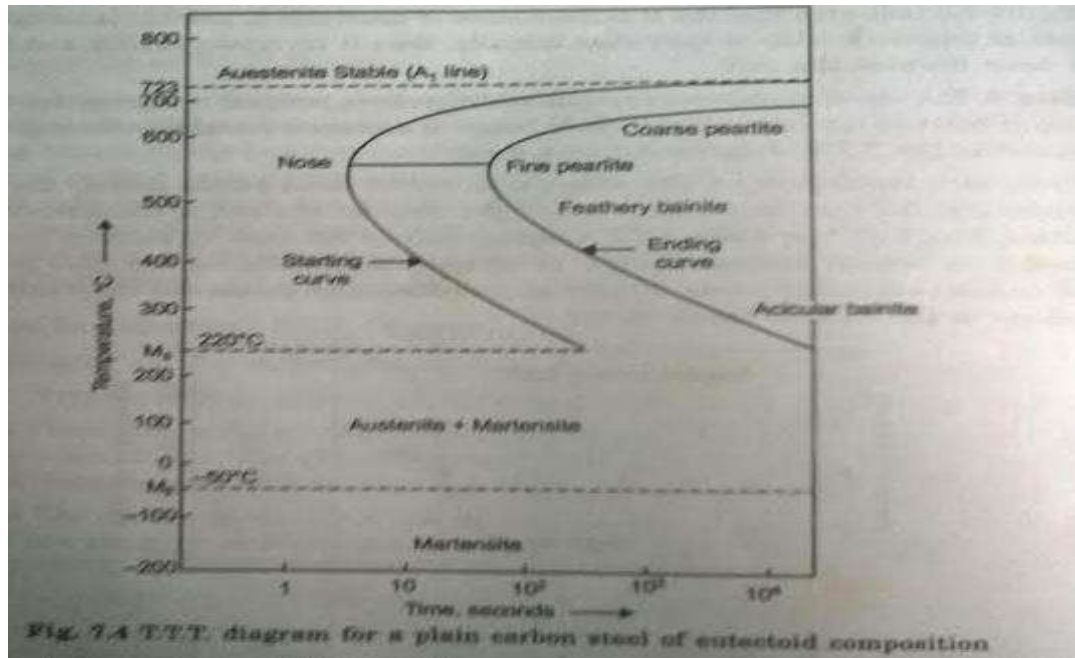

T-T-T DIAGRAM AND COOLIND CURVES: (CCT)

(CCR- critical cooling rate)

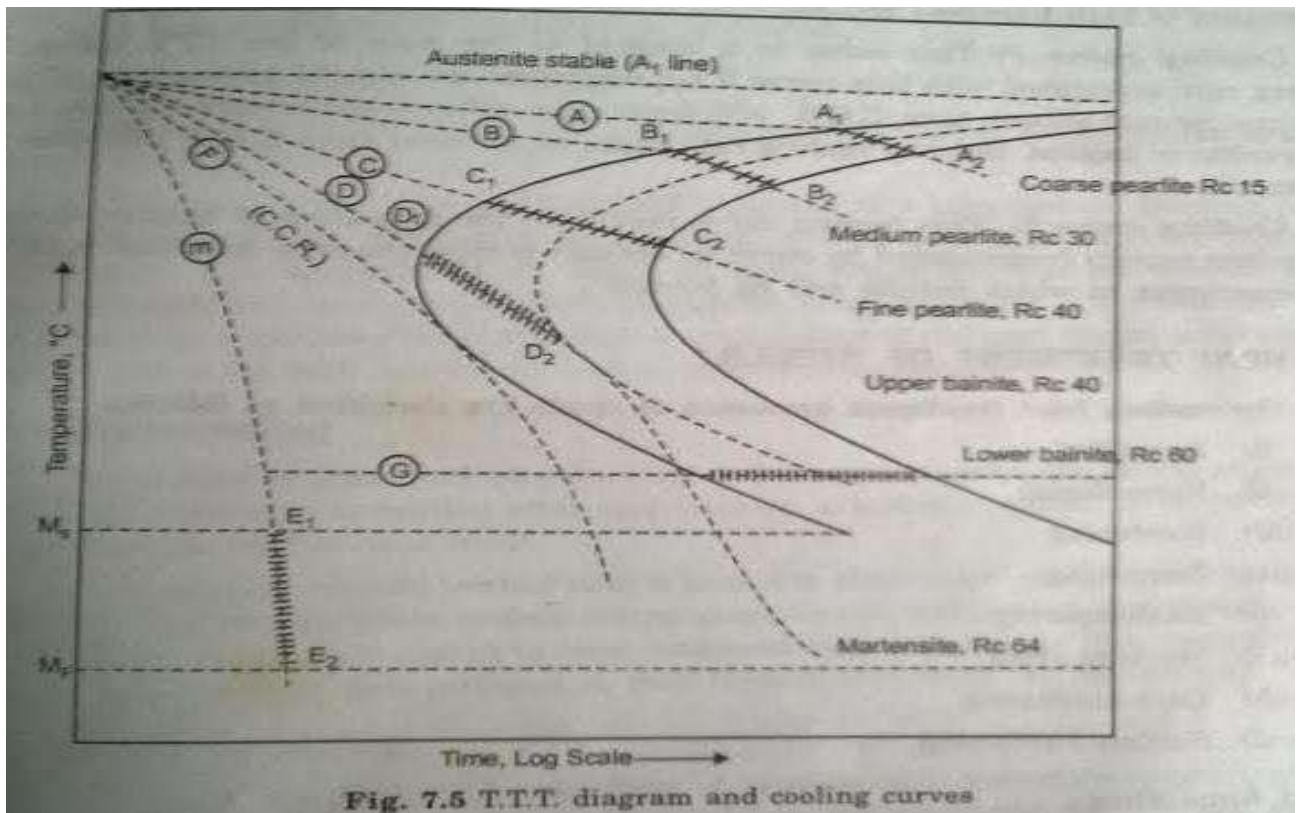

A₁ – A₂ → Annealing → slow
B₁ – B₂ → Normalizing → faster compare to annealing
C₁ – C₂ → oil quenching → slow
D₁ – D₂ → Fine pearlite
E₁ – E₂ → martensite → faster
F → CCR → Faster → M → slower → P & B
G → Bainite rapidly

Cooling curve A: It is an Annealing process it is cooled very slowly. Transformation product is coarse pearlite with low hardness (RC15). The transformation starts at A₁ and ends at A₂.

Cooling curve B: This curve shows faster cooling rate than curve A. This is normalizing operation. The transformation starts at B₁ and ends at B₂ and the resulting product is medium pearlite (RC30)

Cooling curve C: this curve is slow oil quenching and the resulting products consist of mixture of medium and fine pearlite.

Cooling curve D:

This curve is an intermediate cooling rate and at point 'D' the austenite will start transforming into pearlite up to point D₂ and then when M_s is crossed the remaining will instantaneously transformed to martensite. Hence the final microstructure consists of martensite and pearlite.

Cooling curve E: This curve is a drastic quenching it is cooled rapid enough to avoid transformation of in the nose region.

Cooling curve F: This curve is a tangent to the nose of the TTT curve. the cooling rate associated with this curve approximate the critical cooling rate, it form bainite and martensite.

Cooling curve G: This cooling curve results in the formation bainitic structure by cooling rapidly enough to miss the nose and then holding at a temperature at which bainite will be formed.

UNIT-IV

Non-ferrous Metals and Alloys

Lecture notes

CLASSIFICATION OF MATERIALS

Metallic materials are divided into two types

1. Ferrous materials
2. Non-ferrous materials

The ferrous materials are iron based and the non ferrous materials are having some elements other than iron as the principal constituent

The bulk of the non ferrous materials are made up of the alloys of copper, aluminum, magnesium, nickel, tin, lead & zinc. Other non-ferrous materials and alloys are used to a lesser extent include cadmium, molybdenum, cobalt, zirconium, beryllium, titanium and the precious metals gold, silver and the platinum.

IMPORTANT PROPERTIES OF COPPER:-

1. High electrical and thermal conductivity.
2. Good corrosion resistant, machinability, strength and ease of fabrication.
3. It is having pleasing color and can be welded, brazed, soldered and easily finished by plating or lacquering.

APPLICATIONS:-

1. Most of the copper is used for electrical conductors contains over 99.9% copper is identified as electrolyte tough pitch copper [ETP] or oxygen free high conductivity copper [OFHC]
2. ETP copper also used for roofing, gutters, down-spouts, automobile radiators and gaskets, vats, pressure vessels, distillery and process equipment.
3. Oxygen free copper is used in electronics tubes or similar applications because it makes a perfect seal to glass.
4. Arsenic copper contains about 0.3% arsenic has improved resistance to special corrosive conditions and is used for certain condenser and heat exchanger applications.

5. Free cutting copper with about 0.6% tellurium has excellent machining properties and is used for bolts, studs, welding tips and electrical parts such as contact pins, switch gears, relays and precision electrical equipment.

6. Silver bearing copper has a silver content of 70 to 30%. Silver raises the recrystallization temperature of copper thus preventing softening during soldering of commu

It is preferred in the manufacture of electric motors for rail road and air craft use.

Copper Alloys:-

The most important commercial copper alloys may be classified as follows

1. Brasses
2. Bronzes
3. Cupronickels
4. Nickel silvers

Brasses:-

Brasses are alloys of copper and zinc and containing more than 5% zinc. Brasses are classified into two types

- a. α -Brasses
- b. ($\alpha+\beta$) Brasses

a. α -Brasses:-

α -brasses are containing up to 36% zinc possess relatively good corrosion resistance and good working properties. The colours of α brasses varies according to copper content from red for high copper alloys to yellow at about 62% copper so, that those α brasses may be divided into two groups yellow α brasses and red brasses.

α -brasses having 5-22% zinc are in reddish colour and are called as red brasses.

α -brasses having zinc content between 20 to 36% are yellow in colour and are called as yellow brasses.

Commercial brasses:

Commercial brasses contain 90% copper and 10% zinc. It is stronger, harder than pure copper and is used for rivets, screws, jewellery.

Cartridge brass:-

Cartridge brass contains 70% Cu and 30% Zn. It has excellent deep drawing property and is used for making cartridge cases, household articles, radiator fins, lamp fixtures etc.

Admiralty brass:-

Admiralty brass contains 70% Cu and 29% Zn and 1% tin. It has superior corrosion resistance than that of ordinary brass and is extensively used for propellers and marine works.

Aluminium brasses:

Aluminium brasses contain 76% Cu, 22% Zn and 2% Al. It has better corrosion resistance than admiralty brass and hence extensively used for marine works.

$\alpha+\beta$ Brasses:- These contain from 54 to 62% copper. These alloys consist of two phases α and β' . The β' phase is harder and more brittle at room temperature than α . Therefore, these alloys are more difficult to cold work than the α -brasses. At elevated temperatures the β phase becomes very plastic and since most of these alloys may be heated into single phase β region, they have excellent hot working process.

Muntz metal:- The most widely used $(\alpha+\beta)$ brass is Muntz metal which contains 60% Cu and 40% Zn. It has high strength and excellent hot working properties and is extensively used for marine fittings, condenser heads, radiator cores, springs, chains etc....

Naval brasses:- These contain 60% Cu, 39% Zn and 1% tin. It has high corrosion and abrasion resistance and is widely used for condenser plates, propeller shafts and marine works.

2. Bronzes:-

Alloys of copper with other elements except zinc are called bronzes. The most important bronzes are alloys of copper and tin, aluminium, silicon or beryllium. These may also contain phosphorous, lead, zinc or nickel.

1. Tin bronzes or phosphor bronzes:-

Tin bronzes are alloys of copper and tin and contain tin between 1 to 11%. These are also called as phosphor bronze. Phosphorous invariably present as a de oxidizer in casting. The phosphorous content varies from 0.01 to 0.05%.

These bronzes possess high strength, toughness, high corrosion resistance, low coefficient of friction and do not susceptible to season cracking. These are used for bushes, cottor pins, clutch disks, springs, taps, marine pumps etc.... Tin bronzes have good castability and widely used in the foundry.

Gun metal:-

Gun metal contains 88% Cu, 10% tin and 2% Zn. It has considerable strength and toughness and resistance to sea water corrosion. It is used for bushes, nuts, hydraulic fittings, heavy load bearings, marine pumps etc...

Aluminium bronzes:-

Commercial aluminum bronzes contain aluminum between 4 to 11%. Aluminium bronzes containing up to 7.5% Al are generally single phase alloys. While those containing between 7.5 and 11% Al are two phase alloys.

The single phase aluminum bronze have good cold working properties, good strength and good corrosion resistance. These are used for corrosion resistance vessels, nuts, condenser tubes etc...

The properties of two phase aluminum bronzes can be improved by heat treatment. By controlling the composition and by heat treatment the tensile strength of these alloys can be varied from 47 to 95 kg/sq mm with elongation gradually decreasing from 70 to 5%. The heat

treated aluminum bronzes are used for gears, propellers, pump parts, bearing, bushings ,drawing and forming dies etc....

Silicon bronzes:-

These contains 90-97%cu,1-4%si and small amounts of zinc, iron and manganese. The thermal and electrical conductivity of those alloys is about 10% of that pure copper. Silicon bronzes have mechanical properties comparable to that of mild steel and corrosion resistance comparable to that of pure copper. These are used for storage vessels for chemical and gasses, marine construction, nuts, bolts, rivets etc...

Beryllium bronzes:-

Beryllium bronzes contain 1.5-2.25% of beryllium. These alloys can be easily cast, can be easily hot or cold worked and can be easily welded. Like Al alloys, beryllium bronzes can be age hardened and the hardness obtained will vary between 200 to 400 brinell, depending upon the aging time and also tensile strengths upto142kgf sq.mm can be obtained by suitable heat treatment and cold working. The thermal and electrical conductivities of these alloys is comparable to that of pure copper.

These bronzes are used for diaphragms, springs, surgical and dental instruments, gears, watch parts, screws, bearings etc....

Cupro nickels:-

These are the alloys of copper and nickel and contain upto 30% nickel. The copper-nickel binary phase diagram shows complete solubility. So that all cupronickels are single phase alloys. They are not susceptible to heat treatment and may have their properties altered only by cold working.

These alloys have resistance to corrosion fatigue and also high resistance to the corrosive and erosive action of rapidly moving sea water. They are widely used for condenser distiller, evaporator and heat exchanger tubes for naval vessels and costal power plants.

Nickel silvers (German silver):-

Nickel silvers are alloys of copper, nickel and zinc and contain 20-30% Ni, 10-30% Zn and the balance copper. The appearance of those alloys is similar silver and possess good corrosion resistant characteristics. These are mainly used for utensils, costume jewellery, name plates etc...

Aluminium & Aluminium alloys:-**Properties of aluminium:-**

1. It is ductile and malleable due to FCC structure. It can be worked either hot or cold but after recrystallization does not show twins as are seen in Cu & Cu alloys.
2. It is light in weight (specific gravity 2.7 kg/cm³)
3. It has very good thermal & electrical conductivity on weight to weight basis, it carries more electricity than copper.
4. It has excellent ability of getting alloyed with other elements like Cu, Si, Mg, Zn etc....some of the alloys respond to precipitation hardening and some have excellent castability due to this and their light weight & good corrosion resistance and oxidation. They are widely used in automotive and aeronautic fields.
5. Al has good malleability and formability, high corrosion resistance and high electrical & thermal conductivity.
6. Al ultra pure form of aluminium is used for photographic reflectors to take advantage of its light reflectivity and non tarnishing characteristics.
7. Al is non toxic, non magnetic and non sparking. The non magnetic characteristic makes aluminium useful for electrical shielding purposes such as bus bar housings or enclosures for other electrical equipment.
8. One of the most important characteristics of aluminium is its machinability & workability. It can be cast by any known method rolled to any desired thickness, stamped, drawn, spun, hammered, forged and extruded to almost any conceivable shape.

9. These are extensively used for cooking utensils, various architectural components, food and chemical handling and storage equipment and assemblies.

Aluminium-Magnesium Alloys (Magnalium):-

1. Composition:- 5.0% magnesium, 0.5% manganese

Properties:-

1. It is highly resistant to corrosion, machines well.
2. It takes high polish and anodizes well.
3. It has high strength.

Applications:- This type of alloys are used in the marine environments.

2. composition:- 10% magnesium with aluminium.

Properties:-

1. It oxidizes very easily
2. Light weight
3. Machinability good
4. Can be welded

Applications:- These alloys are used for the air craft and automobile components, dairy equipments and architectural work.

Aluminium copper alloys:-

1. These alloys having 4.5% Cu and remaining material should be aluminium
2. This is a precipitation hardenable alloy and produces good strength after precipitation hardening.
3. This alloy has a moderate corrosion resistance and very much susceptible to hot tearing.
4. These alloys are mainly used for air craft castings and for other highly stressed parts due to its good mechanical properties and shock resistance.

Y-Alloys:-

Composition:- 4% Cu, 2% Ni, 1.5% magnesium

1. It has an excellent ability to retain the strength at elevated temperatures with fairly good corrosion resistance.
2. It can be easily cast and hot worked.

Applications:- These alloys are mainly used for pistons and cylinder heads of diesel and high duty petrol engines.

Induminium:-

1. It contains about 5% Cu & 1.5% Ni with small amounts Mn, Ti, Sb, Co and Zr.
2. It is superior to γ -alloys at elevated temperature service particularly in respect of creep resistance.
3. It is used in aero engines and other continuous elevated temperature service applications up to 300°C.

Duralumin:-

It contains 3.5-4.5% Cu, 0.4-0.7% Mn, 0.4-0.7% Mg, Fe or Si <0.7%, Al balance.

Properties:-

1. It possesses high machinability.
2. It has high tensile strength.
3. Excellent casting & forging properties.

Applications:-

1. Air craft and automobile parts.
2. Al-bars, sheets, tubes and rivets etc...

Titanium & its alloys:-**Major characteristic & properties of Titanium:-**

1. Titanium is one of the few allotropic metals i.e it can be exist in two different crystallographic forms. At room temperature it has a close packed hexagonal structure, designated as the Alpha-phase.

At around 885°C, the alpha phase transforms to body centered cubic structure, known as the beta phase which is stable upto titanium's melting point of about 1680°C.

2. Titanium mechanical properties are closely related to these allotropic phases. For example the beta phase is much stronger but more brittle than the alpha phase.
3. Ti-alloys can be usefully classified into three groups on the basis of allotropic phases i.e alpha, beta & alpha-beta alloys.
4. Ti & Ti-alloys are having attractive engineering properties. They are about 40% lighter than steel & 60% heavier than aluminium. The combination of moderate weight and high strengths up to 1400kg/cm², gives titanium alloys the highest strength to weight ratio of any structure metal roughly 30% greater than aluminium &

This exceptional strength to weight ratio is maintained from -220°C up to 540°C

5. A second outstanding property of titanium material is corrosion resistance. The presence of a thin, tough oxide surface film provides excellent resistance to atmospheric and sea environments as well as a wide range of chemicals, including chlorine and organics containing chlorides. Being near the chloride end of the galvanic series, titanium performs the function of a noble metal.
6. Other notable properties are a higher melting point than iron, low thermal conductivity, low co-efficient of expansion and high electrical resistivity.

Applications:-

These titanium and its alloys are used for surgical implants, marine hard ware, compressors & valve bodies.

Titanium alloys:-**Alpha alloys:-**

1. These alloys contain the alloying elements as aluminium, tin, columbium, zirconium, vanadium and molybdenum in amounts varying about 1-10%.
2. They are non heat treatable, having good stability up to 540°C and down as low as -220°C. They have good combination of weldability, strength and toughness.
3. The 5% Al and 25% tin alloy is the most widely used alpha alloy has been employed in numerous space and air craft applications.
4. It has strength at room temperature of 8400kg/cm², acceptable ductility and is useful at room temperature up to 430 and 540°C. In addition, it has good oxidation resistance and good weldability and formability.

Alpha-Beta alloys:-

This is the largest and most widely used group of titanium alloys. Because these alloys are a two phase combination of alpha & beta alloys, their behaviour falls in a range between the two, single phase alloys.

1. They are heat treatable, useful up to 430°C, more formable than alpha alloys, but less tough and more difficult to weld.
2. The most popular alloy in this group is the 6% Al & 4% vanadium. It can be heat treated up to 11,972kg/cm² has good impact and fatigue strength and unlike other alpha-beta alloys is weldable.
3. The 6% Al, 6% vanadium & 2% tin alloy is heat treatable to higher strength than any other alpha beta alloy(13380kg/cm²)

Beta alloys:-

These beta alloys have exceptional high strength over 14085kg/cm². Their lack of toughness and low fatigue strength limits their use. They retain an unusually high percentage of strength up to 320°C but cannot be used at much higher temperature and they become brittle at temperature below -40°C.

UNIT-V

Ceramics, Polymers and Composites

Lecture notes

IMPORTANT PROPERTIES:

1. ceramic`s are in-organic, non-metallic materials that are pass and /or used at high temperatures
2. They have been subjected to heat treatment
3. They are generally hard & brittle materials that with stand compression very well
4. They are abrasive resistance, heat resistance & can curtain large compressive loads even at high temperature
5. many ceramic`s are chemically inert even at high temperatures as shown by good oxidation and reduction resistance at these temperature
6. The nature of chemical bond in ceramics generally ionic in character and the coins play on important role in the determination of the properties of the material

EX: anions, carbides, borides, nitrides, oxides.

TYPES OF CERAMIC`S: 1. Classification of ceramics based on function

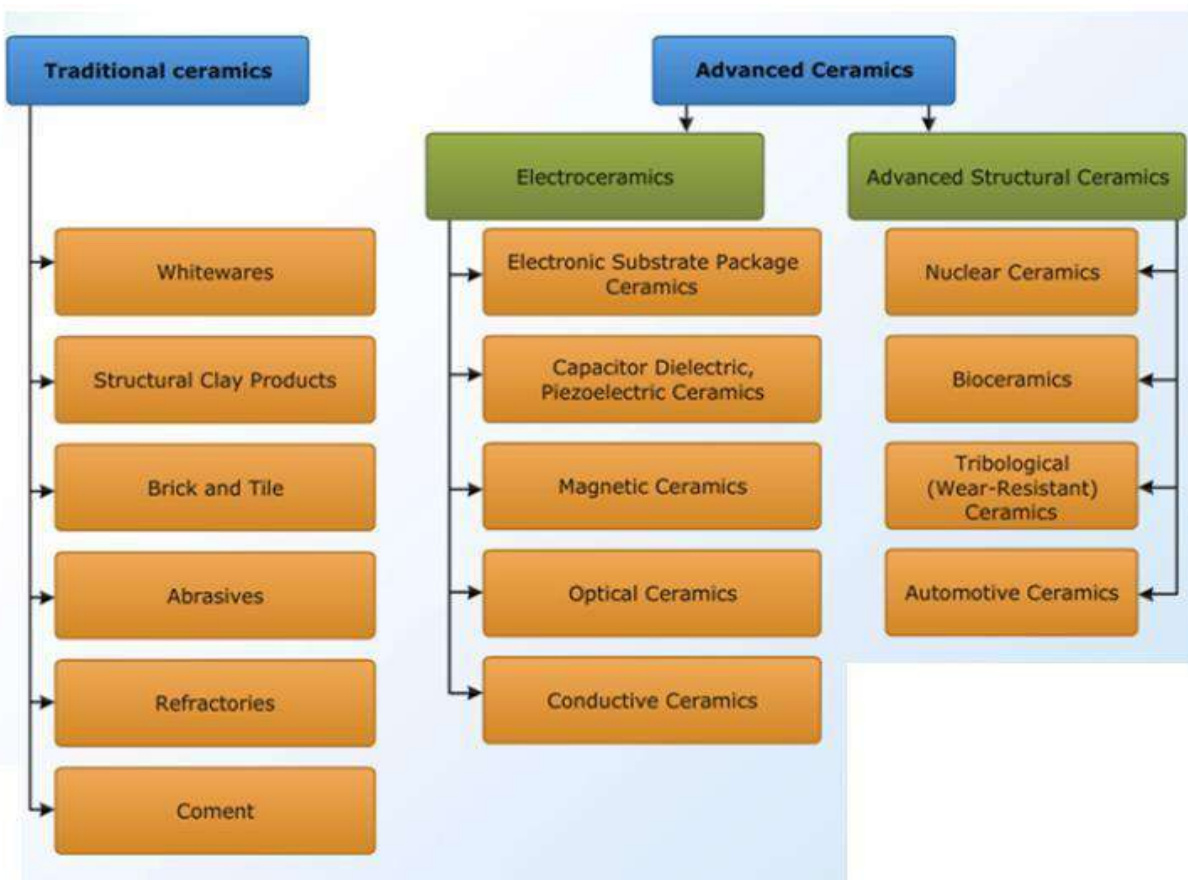

EXAMPLES OF CERAMIC MATERIALS:

1. All types of glass product including fibers etc..
2. Cements, lime, plaster
3. Abrasives & some types of cutting of tools
4. Bricks, tiles, drains, pipes etc..
5. Refractories for high temperature use
6. Electrical insulators, Ferro magnetic, semi conductors

STRUCTURAL CLASSIFICATION:

1. CRYSTALLINE CERAMICS:

These are single phase like MgO to multi phase from MgO to Al_2O_3 binary system.

2. **NON-CRYSTALLINE CERAMICS:** natural & synthetic in-organic glasses.
3. **GLASS-BONDED CERAMICS:** fire clay products-crystalline phase are held in glass matrix
4. **CEMENTS:** crystalline (or) non-crystalline phases.

ADVANTAGES OF CERAMIC MATERIALS:

1. The ceramics are hard, strong & dense.
2. They have high resistance to the action of chemicals and to the weathering
3. Possess a high compression strength compared with tension
4. They offer excellent dielectric properties
5. They are good thermal insulators
6. Good sanitation
7. Better economy

APPLICATIONS:

1. **WHITE WARES:** tools, sanitary wares, high frequency applications, chemical industries etc
2. **NEWER CERAMICS:** borides, carbides, nitrides, single oxides, mixed oxides, silicates, insulators, semi conductors, fuel elements, fuel containers, control rods etc..

3. **ADVANCED CERAMICS:** these are in I.C engines, turbines, cutting tools, energy conversation, strong & generation

PROPERTIES OF CERAMIC MATERIALS:

MECHANICAL PROPERTIES:

1. Compressive strength is high
2. It is brittle
3. These passes ionic & covalent bond
4. More force required
5. Rigidity high at temperature

ELECTRICAL PROPERTIES:

Di-electric constant:

It is the ratio of capacitance of a di-electric compared to the capacitance of air under the same conditions

Di-electric strength:

It is the ability of a material to with stand electrical break down volume & surfaces resistivity

Thermal properties:

1. Thermal conductivity
2. Thermal capacity
3. Thermal-shock-resistance

STRUCTURE OF CRYSTALLINE CERAMICS:

Most ceramic phases, like metals, have crystalline structure. Ceramic crystals are formed by either a pure ionic bond, a pure covalent (or) by bonds that passes the ionic as well as covalent characteristics.

Ionic bonds give ceramic materials of relatively high stability and high melting point

Covalent crystal:

1. Passes high hardness
2. High melting point & low electrical conductivity at room temperature

CRYSTAL STRUCTURES IN CRYSTAL CERAMICS:

1. Rock salt structure
2. zinc blend structure
3. wurzite structure
4. spinel structure
5. fluorite structure
6. ilmenite structure
7. Cesium chloride structure

ADVANCED CERAMICS:

1. Glass ceramics:

The compositions in which nucleation and crystallization have been commercially produced are MgO; Al₂O₃- SiO₂; LiO₂-AL₂O₃-SIO₂; LiO-MgO-SiO

Characteristics:

1. Very low co-efficient of thermal expansion
2. High mechanical strength and thermal conductivity

APPLICATOINS: over ware, table ware & as insulators

2. Die- electric ceramics:

Non linear electric ceramics are suitable in the miniaturation of electric part which have had to the development of increasingly sophisticated electrical circuits and also used in capacitors

2. Electronic ceramics:

There are two types of electronic ceramics that are ferrite, Ferro-electric ceramics

Ferrite are mixed metal-oxide ceramics

- ❖ Ferro-electric ceramics are can convert electrical signal into mechanical energy

CERMETS:

- ❖ Cermets are ceramic & metal compositions
- ❖ It contains Al_2O_3 & Cr varying proportions.
- ❖ The most common cermets is the cemented carbide which is composed of extremely hard particles of a refractory carbide such as tungsten carbide (or) titanium
- ❖ These components are utilized extensively as cutting for hardened steels
- ❖ These are manufactured from the powders of ceramics metals by powder metallurgy

APPLICATIONS:

1. These are used in jet engines, brake shoe, linings & oxidation resistant parts
2. Used as spinning tools for hot forging dies and other similar high temperatures applications
3. These are also suitable for cutting of metals at high speeds with medium to light chip loads

GLASSES:

1. Glass is a transparent silica product which may be amorphous (or) crystalline. Depending upon the heat treatment
2. Glass is an inorganic product of fusion of one (or) more oxides of silicon, boron, calcium, magnesium, Na etc ... cooled to rigid material without crystallization
3. Glasses mostly consist of inorganic oxides such as SiO_2 & B_2O_3 are known as glass formers
many other oxides such as Al_2O_3 , CaO , Na_2O , MgO etc... are added to glass forming oxides to obtain desired combination of properties such as refractive index, electrical conductivity etc...

STRUCTURE OF GLASS:

Unlike most other ceramic materials glass is non-crystalline to manufacture it is a mixture of silica and other oxides is melted and then cooled to a rigid condition.

Glass does not change from liquid to solid at a fixed temperature but remains in the supercooled liquid state and it is considered as a supercooled liquid

Fig: Amorphous non-crystalline structure of glass

GLASS PRODUCTION & PROCESSING STEPS:

1. Melting & refining ~ melting point = 1500 c
2. Forming & shaping
3. Heat treatment
4. Finishing

PROPERTIES OF GLASS:-

1. **Viscosity:** - which determines the suitability of glass for drawing into tubes, rods, for blowing & rolling

2. Chemical stability:-

Which determines the suitability of glass for making chemical wears & optical glasses

3. **Optical properties:**-this determine the stability of glass for use in optical system

4. **Mechanical properties:**-tensile strength & wear resistance.

5. **Electrical properties:** - good conductivity di-electric and determine the stability of glass for manufacturing the incandescent lamps, radio, valves, x-ray tubes etc

APPLICATIONS OF GLASS:-

1 in doors, windows, furnitures etc..

2. Laboratory equipment & chemical glass wear

3. X-ray tubes, glass tubes, fiber glass insulation, optical glasses

TYPES OF GLASSES:-

1. Soda lime (or) crown glass

2. flint glass

3. pyrex (or) heat resistant glass.

1) SODA LIME (OR) CROWN GLASS:-

1. It is the cheapest quality of glass

2. available in clean & clear state

3. Easily fusible at comparatively low temperatures.

COMPOSITION BY WEIGHT:-

Sand	–	75 parts
lime	-	12.5 parts
Soda	–	12.5 parts
Alumina	-	1 part
Waste glass	50 –	100 parts

Applications: - window glass, plate glass, bottles, glass etc...

2. FLINT GLASS:-

- ❖ it provide better lastre than sodium glass
- ❖ in this load provides brilliance & high polish

COMPOSITION BY WEIGHT: -

sand 100 parts
red lead 70 parts
potash 32 parts
waste glass 10 parts

Applications:- table wears, optical glasses, electrical resistance materials

3. PYREX (OR) HEAT RESISTANT GLASS:-

Which are used extensively for cooking utensils and laboratory wares, are borosilicate glasses.

COMPOSITION BY WEIGHT: -

Silica – 80 parts
borox oxide -14 parts
sodium oxide - 4 parts
alumina 2 parts with trasses of potassium oxide, calcium oxide, mg oxide..

HIGH SILICA GLASS: -

- ❖ These are containing 96% silica.
- ❖ These are used where high temperature resistance is required
- ❖ These are used regularly at temperatures up to about 900 c
- ❖ High silica glasses are have a very low thermal expansion co-efficient which accounts for this high resistance to thermal shock.

SPECIAL TYPES OF GLASS:-

Annealing glass, sheet glass, plate glass, fluted glass, ground glass, wired glass, safety glass, bullet-proof glass, insulating glass, foam glass, glass blocks, soluble glass, ultra violet glass, structural glass, glass fiber (or) glass war.

ABRASIVES:-

1. An abrasive is commonly made of ceramic material
2. An abrasive is hard, mechanically resistance i.e material used for grinding (or) cutting
3. An abrasive an wear away softer material
4. An abrasive may be natural (diamond) (or) synthetic
5. Synthatic abrasives are prefer because greater uniform of hardness & structure can be obtained and other desired properties can be introduced.

CLASSIFICATION OF ABRASIVES:-

1. Hard Abrasives
2. Siliceous Abrasives
3. Soft Abrasives
4. Artificial Abrasives

1. HARD ABRASIVES:-

- ❖ These are diamond, corundum, emery and garnet
- ❖ (i) Diamond is a crystalline form of carbon found in nature diamond is the hardest material known and it out lasts other abrasive by factors of 10-100 more.

Uses: wire drawing dies, drills for drilling hard locks, dressing for grinding wheels, polishing (or) carbide metals glasses, ceramics etc

EMERY:-

1. It is a natural abrasive
2. Emery papers are used polishing metal

SILICEOUS ABRASIVES:-

These abrasives are quartz, flint, chart, quartzite, sand stone and plumice which are all compassed chiefly of silica.

Sand Stone:-

1. It is a natural abrasive
2. .it is used for sharpening wood working tools

Quartz:

1. It is a natural abrasive
2. It is used for sand paper for wood & fine grinding

ARTIFICIAL ABRASIVE: -

SiC:-

1. It is a synthetic, artificial (or) manufactured abrasive
2. To manufacture sic sand. Cock & sea dust are mixed at high temperature electrical arc (4500c) is passed through a mixture for a long time .the center of the mixture is converted into sic which is then crushed

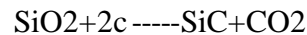

Applications: -

1. Sic better known by one of its trade name carborcndum
2. For making grinding wheels
3. for refraction material
4. .as heating, element in the electrically heated industrial furnaces
5. as pipe
6. 6.it is used as a pumps for pumping sand

Al₂O₃ (ALUMINIUM OXIDE):-

1. It is obtained by heating AL salts
2. A wide variation of properties is possible depending upon the treatment
3. It has a color, lighter then sic
- 4.it is not quite so hard as sic , but is tough and more resistance to impact

USES: -

1. for polishing cast iron, non-ferrous metals and high nature finishing of stainless steel.
2. Floor sanding machine

NANO TECHNOLOGY:-

❖ nano technology is the technology that controls matter at a smaller scale can bring miniraiturisation of things

Which is a luxury for the present generation but nesting for the future generation?

❖ It is the only technology which is found to be multi disciplinary that the scientific communities of various disciplinary throughout the world are involved in developing a new kind of material era..

Various studies of a nano particle, reveals, that at nano scale, the properties of traditional materials change and the behavior of surface starts to dominate the behavior of bulk material

- ❖ Nano materials are crystalline materials having grain size on the order of many atoms
- ❖ nano materials normally have grain size very from microns to millimeter
- ❖ A micron is a millionth of meter (10^6). A nano meter is very smaller then even microns with is a billionth of meter (10^{-9})
- ❖ nano materials can be in-organic, organic as well as bio-organic materials
- ❖ Anano-crystalline materials have grain of the order of 1-100nm

MAJOR FIELDS OF NANO TECHNOLOGY:-

- ❖ One of the important fields of development in the biotechnological field.
- ❖ In this field the manipulation of genes tissue engineering, drug system etc...of nano sale levels
- ❖ This technology is used in computers, cell phones, bio-medical robots, batteries, sensors. Solar cells etc. Will produce fruit feel results & in the future.

AREAS OF COMMERTIAL APPLICATION OF NANO TECHNOLOGY IN FEATURES: -

even through the real fruits of nano technology will reach the people after 10-18 years period of time these include tissue engineering, genetic engineering, cancer research, medical imaging system, carbon nano tubes, sensors, lubricants, films, paints, explosives, textiles etc..

APPLICATIONS OF NANO MATERIALS:-

1. Tougher & harder cutting tools :-

Nano materials cutting tools made of nano crystalline, tic, tantalum, carbide are extremely tough with very high wear-resistance. Such cutting tools can operate at higher temperatures with higher speed reducing the production time.

Also miniaturized cutting tools such as micro drill and cutters with enhanced edge, endurance and wear resistance. can Successfully careful in micro electronic system

❖ **Mechanical ceramics:-** sic, silicon nitride, have been applied in automatic applications such as high strength springs ,ball bearings ,due to their excellent physical chemical & mechanical properties

COMPOSITE MATERIALS:-

Composite materials are produced by combining two dis-similar materials into a new material that may be better suited for a particular application than either of the original material alone.

Ex: - Fiber glass, Reinferced plastics commonly used in house hold goods and in many industrial applications.

Their plastic alone is relatively weak& has low elastic modulus i.e., it bends and stretch easily. The glass fiber provides strength and stiffness; their modulus of elasticity may be sometimes more than that of plastics. Since glass fiber can with stand much higher tensile strength before yielding occurs. They take most of load when composite is stressed.

Metals, Ceramics, Glasses, Polymers and cement can be combined in composite materials to produce unique characteristics such as stiffness, toughness and high temperature strength.

Many composite materials are composed of just two phases one is termed as matrix which is continuous and the other phase often called the dispersed phase

Classification of composite materials:-

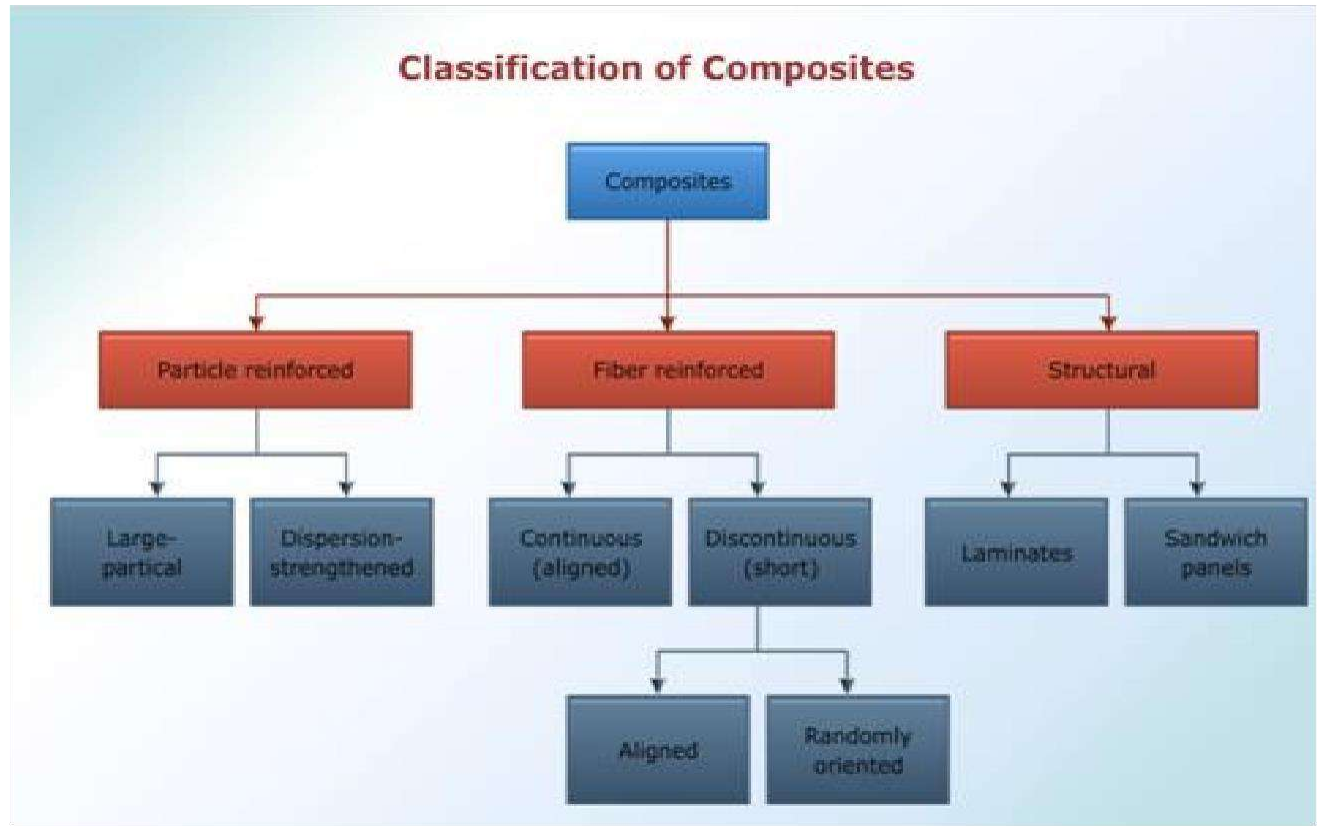

Manufacturing of composites

1. **Open Mold Processes-** some of the original FRP manual procedures for laying resins and fibers onto forms
2. **Closed Mold Processes-** much the same as those used in plastic molding
3. **Filament Winding-** continuous filaments are dipped in liquid resin and wrapped around a rotating mandrel, producing a rigid, hollow, cylindrical shape

- ❖ A polymer matrix composite (PMC) is a composite material consisting of a polymer imbedded with a reinforcing phase such as fibers or powders
- ❖ FRP composites can be designed with very high strength-to-weight and modulus-to-weight ratios
- ❖ These features make them attractive in aircraft, cars, trucks, boats, and sports equipment

Particle Reinforced Composite:-

The dispersed phase of particle reinforced composite is equi axed (Particle dimensions are approx same in all directions)

Large particle Composite:-

Fillers are added to some polymeric materials produces large particle composite. The fillers modified or improve the properties of materials and replace some of the polymers volume with less expensive fillers materials

Ex:-

1. Concrete is an example of large particle composites. It is composed of cement and sanded gravels. The particles have a variety of geometry but they should be approximately the same dimensions in all in all directions (equi axed).
2. Particles should be small and evenly distributed through matrix for effective reinforced. More over the volume fraction of the two phases influence the behavior.
3. Mechanical properties are enhanced with increasing the particulate content.
4. Large particles composites are utilized with 3 material types i.e., Metals, Ceramics and polymers.

Example of ceramic metals composites are cermet, cementite carbide which are composed of extremely hard particles of a refractory carbide ceramics. Such as Wc , TiC etc.... embedded in a matrix of metals such as **Cu** or **Ni** is the common cermet. These composites are widely used as a cutting tools.

Dispersed strengthen Composite:-

This type of composite contains small particulates with increases the strength of the composite by blocking the movement of dislocation.

Ex:-Sintered Aluminium Powder (SAP)

SAP has an Al matrix which contains up to 14% Al_2O_3 . This composite is produced with powder metallurgy process where the powder are mixed compacted at high pressure and sintered together.

Sintering involves heating a material until the particles of the material fuse together only the particles are generally bonded together the whole doesn't melt.

Application:- Ag-cdo used as a electrical contact material

Pb-pbo used in battery plates

Ba-bao used in nuclear reactors & aerospace components

The high temp strength of Ni alloy may be enhanced significantly by the addition of about 3% volume of Thoria (ThO_2) as finely dispersed particles. This material is known as Thoria dispersed Nickel.

Fiber Reinforced Composite:-

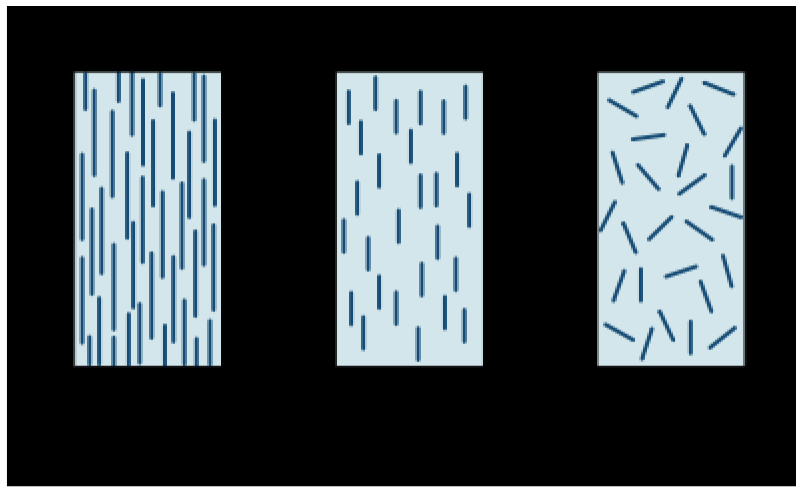

Fig: fiber Reinforced Composite

These are strong fibers embedded in a strong matrix produce products with high strength to weight ratio.

The matrix material transmits the load to the fibers, which absorbs the stress.

2. Fiber reinforced composite with exceptionally high specific strength and moduli have been produced that utilize low density fillers and matrix materials.

3. Some critical length is necessary for effective strengthening and stiffening the composite material. The critical length (l_c) depends upon the fiber diameter (d) and its ultimate tensile strength (σ_f) and matrix bond strength (τ_c).

➤ To get effective strengthening and stiffening of composite material, critical fiber length is necessary

$$l_c = \frac{\sigma_f d}{2\tau_c}$$

➤ The length of the fiber should be 15 times ($l \gg l_c$) greater than the critical length, for continuous fiber reinforced composites

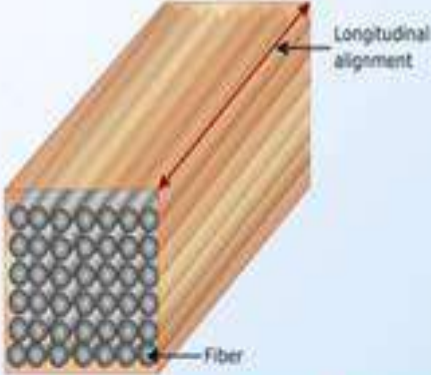

The diagram illustrates a continuous fiber reinforced composite. It shows a rectangular block with a grid of fibers on the front face. A red arrow points along the length of the block, labeled 'Longitudinal alignment'. A black arrow points to one of the fibers in the grid, labeled 'Fiber'.

Continuous Fiber Reinforced Composites

2. DISCONTINUOUS FRP:

- The fiber length in this, has the shorter lengths and the alliance between the matrix and fiber is given out at the fiber's end
- Based on the alignment it can be further subdivided

- **Aligned:** In this composites, fibers are aligned parallel to each other. It is shown in the image.



Aligned

- **Random:** In this composites, fibers are aligned randomly to each other as shown in the image.



Random

Fabrication of FRP: Fabrication processes of composites are

- ❖ Hand layup process
- ❖ Filament winding process
- ❖ Pultrusion process

Hand layup process

Hand Lay-up Process

- Hand lay-up is one of the simple production methods for composite
- The reinforcing material is placed in the mold for hand lay-up parts unless the composite is to be connected directly to another structure



Basic Process of Hand Lay-up

Filament Winding

- Filament windings should be made or purchased, as they have to be wound at exact locations on a mandrel

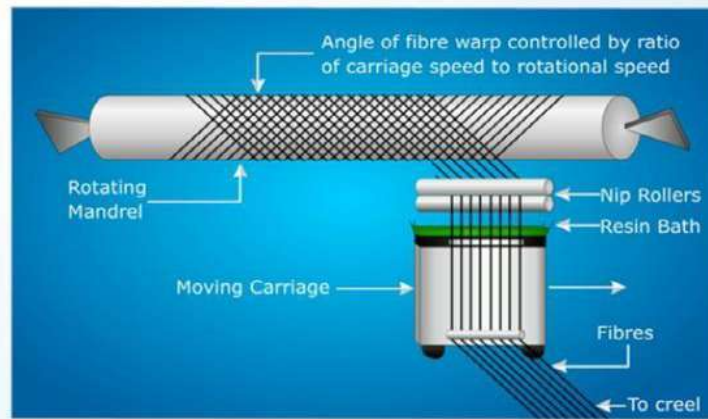

Basic Process of Filament Winding

Pultrusion

- Continuous fibers pulled through resin tank, then performing die & oven to cure

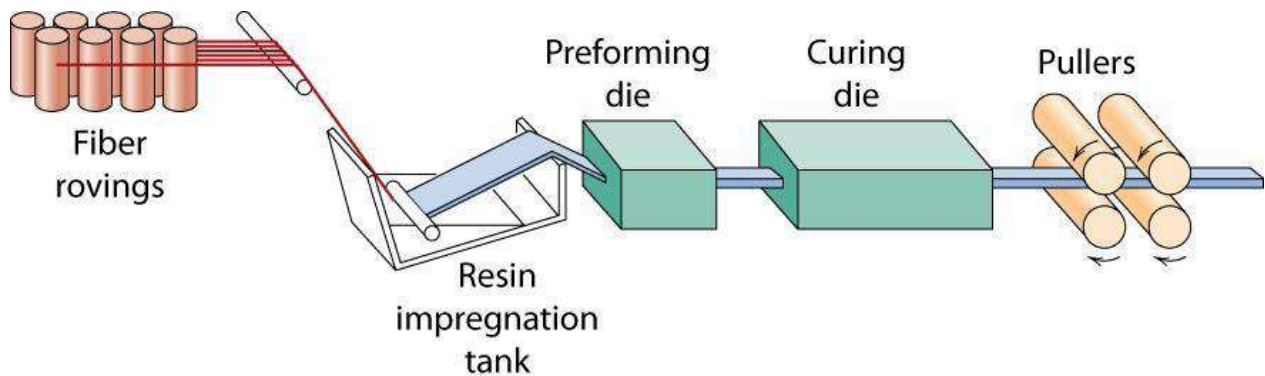

Fig: Pultrusion process

- Based on the stacking of the layers they can be divided as
 - Laminar composites
 - Sandwich panels
 - Hybrid composites
- A Structural composite is composed of both homogenous and composite materials

Laminar Composites

Laminar Composites

- Laminar composites are composed of two dimensional sheets
- In this composites, the layers are stacked together and the orientation of high strength direction varies with each successive layer

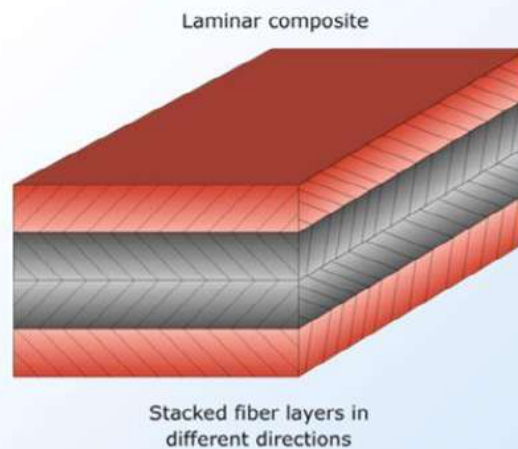

Laminar Composites

Sandwich panels

- In this composite, less dense material can separate the two strong outer sheets
- Layer of less dense material has lower hardness and less strength
- The faces bear most of the in-plane loading and also any transverse bending stress

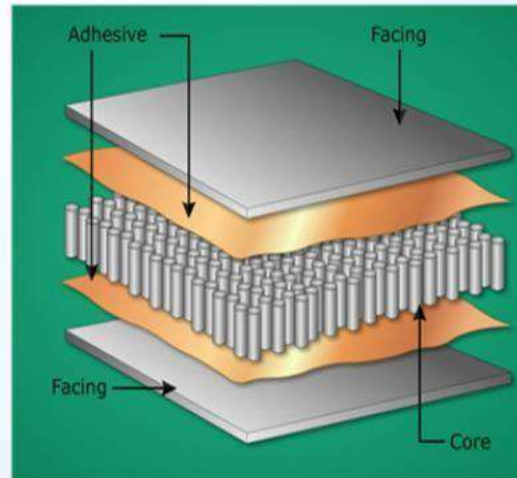

Sandwich Panels

Hybrid composites

- They are obtained by using two or more different kinds of fiber in a single matrix
- Failure does not happen suddenly, when hybrid composites are stressed in tension

Types of composites

Cermets/Ceramal

The Cermet is an abbreviation for the "ceramic" and "metal." A Cermet is a composite material composed of ceramic (Cer) and metallic (Met) materials. A Cermet is ideally designed to have the optimal properties of both a ceramic, such as high temperature resistance and hardness, and those of a metal, such as the ability to undergo plastic deformation. The metal is used as a binder for an oxide, boride, carbide, or alumina. Generally, the metallic elements used are nickel, molybdenum, and cobalt. Depending on the physical structure of the material, cermets can also be metal matrix composites, but cermets are usually less than 20% metal by volume.

It is used in the manufacture of resistors (especially potentiometers), capacitors, and other Electronic components which may experience high temperatures.

Some types of cermet are also being considered for use as spacecraft shielding as they resist the high velocity impacts of micrometeoroids and orbital debris much more effectively than more traditional spacecraft materials such as aluminum and other metals.

One application of these materials is their use in vacuum tube coatings, which are key to solar hot water systems. Cermets are also used in dentistry as a material for fillings and prostheses. Also it used in machining on cutting tools.

Cermets are one of the premier groups of particle strengthened composites and usually comprises ceramic grains of borides, carbides or oxides. The grains are dispersed in a refractory ductile metal matrix, which accounts for 20 to 85% of the total volume. The bonding between ceramic and metal constituents is the result of a small measure of mutual solutions.

Metal oxide systems show poor bonding and require additional bonding agents. Cermet Structures are usually produced using powder metallurgy techniques. Their potential properties are several and varied depending on the relative volumes and compositions and of the metal and ceramic constituents. Impregnation of a porous ceramic structure with a metallic matrix binder is another method used to produce cermets. Cermets may be employed as coating in a powder form. The powder is sprayed through a gas flame and fused to a base material. A wide variety of cermets have been produced on a small scale, but only a few have appreciable value commercially.

Carbon-carbon composites

- Carbon-carbon composites can be produced in two basic ways
- Both involve the infiltration of a carbon-bearing fluid into the interstices between an array of carbon fibers
- In both cases, the main concern is achieving complete infiltration in a reasonably short time

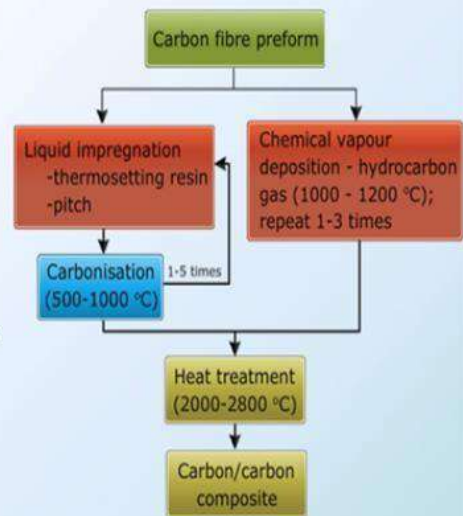

Production Process of Carbon-Carbon Composites

Metal matrix composites (MMCs):

- Metal matrix composites (MMCs), consist of at least two chemically and physically distinct phases, suitably distributed to provide properties not obtainable with either the individual phases
- Fracture, high strength, toughness and hardness can be offered by metal matrix composites
- When metal matrix materials require high modulus reinforcements, then these composites offer high strength

Introduction

Although it is undoubtedly true that the high strength of composites is largely due to the fiber reinforcement, the importance of matrix material cannot be underestimated as it provides support for the fibers and assists the fibers in carrying the loads. It also provides stability to the composite material. Resin matrix system acts as a binding agent in a structural component in which the fibers are embedded. When too much resin is used, the part is classified as resin rich. On the other hand if there is too little resin, the part is called resin starved. A resin rich part is more susceptible to cracking due to lack of fiber support, whereas a resin starved part is weaker because of void areas and the fact that fibers are not held together and they are not well supported.

Matrix Selection

Thermodynamically stable dispersions are essential for the use of metal matrix composites for high temperature applications. This can be done by using an alloy dispersion system in which **solid state diffusivity**, **interfacial energies** and **elemental solubility** are minimized, in turn reducing coarsening and interfacial reactions. Aluminium and magnesium alloys are regarded as widely used matrices due to low density and high thermal conductivity. Composites with low matrix alloying additions result in attractive combinations of ductility, toughness and strength. In discontinuous reinforced metal matrix composites minor alloying elements, used in wrought alloys as grain refiners, are not required. These additions should be avoided since coarse inter-metallic compounds get formed during consolidation, thus, reducing the tensile ductility of the composite.

Role of matrix materials

The choice of a matrix alloy for an MMC is dictated by several considerations. Of particular importance is whether the composite is to be continuously or discontinuously reinforced. The use of continuous fibers as reinforcements may result in transfer of most of the load to the reinforcing filaments and hence composite strength will be governed primarily by the fiber strength. The primary roles of the matrix alloy then are to provide efficient transfer of load to the fibers and to blunt cracks in the event that fiber failure occurs and so the matrix alloy for continuously reinforced composites may be chosen more for toughness than for strength. On this basis, lower strength, more ductile, and tougher matrix alloys may be utilized in continuously

reinforced composites. For discontinuously reinforced composites, the matrix may govern composite strength. Then, the choice of matrix will be influenced by consideration of the required composite strength and higher strength matrix alloys may be required.

Additional considerations in the choice of the matrix include potential reinforcement/matrix reactions, either during processing or in service, which might result in degraded composite performance; thermal stresses due to thermal expansion mismatch between the reinforcements and the matrix; and the influence of matrix fatigue behavior on the cyclic response of the composite. Indeed, the behavior of composites under cyclic loading conditions is an area requiring special consideration. In composites intended for use at elevated temperatures, an additional consideration is the difference in melting temperatures between the matrix and the reinforcements. A large melting temperature difference may result in matrix creep while the reinforcements remain elastic, even at temperatures approaching the matrix melting point. However, creep in both the matrix and reinforcement must be considered when there is a small melting point difference in the composite.

Functions of a Matrix

In a composite material, the matrix material serves the following functions:

- Holds the fibers together.
- Protects the fibers from environment.
- Distributes the loads evenly between fibers so that all fibers are subjected to the same amount of strain.
- Enhances transverse properties of a laminate.
- Improves impact and fracture resistance of a component.

Helps to avoid propagation of crack growth through the fibers by providing alternate failure path along the interface between the fibers and the matrix.

- Carry interlaminar shear.

The matrix plays a minor role in the tensile load-carrying capacity of a composite structure. However, selection of a matrix has a major influence on the interlaminar shear as well as in-plane shear properties of the composite material.

The interlaminar shear strength is an important design consideration for structures under bending loads, whereas the in-plane shear strength is important under torsion loads. The matrix provides lateral support against the possibility of fiber buckling under compression loading, thus influencing to some extent the compressive strength of the composite material. The interaction between fibers and matrix is also important in designing **damage tolerant structures**. Finally, the processability and defects in a composite material depend strongly on the physical and thermal characteristics, such as viscosity, melting point, and curing temperature of the matrix.

Desired Properties of a Matrix

The needs or desired properties of the matrix which are important for a composite structure are as follows:

- Reduced moisture absorption.
- Low shrinkage.
- Low coefficient of thermal expansion.
- Good flow characteristics so that it penetrates the fiber bundles completely and eliminates voids during the compacting/curing process.
- Reasonable strength, modulus and elongation (elongation should be greater than fibre).
- Must be elastic to transfer load to fibers.
- Strength at elevated temperature (depending on application).
- Low temperature capability (depending on application).
- Excellent chemical resistance (depending on application).
- Should be easily process able into the final composite shape.
- **Dimensional stability** (maintains its shape).

As stated above, the matrix causes the stress to be distributed more evenly between all fibers by causing the fibers to suffer the same strain. The stress is transmitted by shear process, which requires good bonding between fiber and matrix and also high shear strength and modulus for the matrix itself. One of the important properties of cured matrix system is its glass transition temperature (T) at which the matrix begins to soften and exhibits a decrease in mechanical properties. The glass transition temperature is not only an important parameter for dimensional stability of a composite part under influence of heat, but it also has effect on most of the physical properties of the matrix system at ambient temperature.

As the load is primarily carried by the fibers, the overall elongation of a composite material is governed by the elongation to failure of the fibers that is usually 1-1.5%. A significant property of the matrix is that it should not crack.

The function of the matrix in a composite material will vary depending on how the composite is stressed. For example, in case of compressive loading, the matrix prevents the fibers from **buckling** and is, therefore, a very critical part of the composite since without it; the reinforcement could carry no load. On the contrary, a bundle of fibers could sustain high tensile loads in the direction of the filaments without a matrix. Some of the physical properties of the matrix which influence the behavior of composites are:

- **Shrinkage** during cure,
- Modulus of elasticity,
- Ultimate elongation,
- Strength (tensile, compressive and shear), and
- **Fracture toughness**.

Factors considered for Selection of Matrix

In selecting matrix material, following factors may be taken into consideration:

- The matrix must have a mechanical strength commensurate with that of the reinforcement i.e. both should be compatible. Thus, if a high strength fiber is used as the reinforcement, there is no point using a low strength matrix, which will not transmit stresses efficiently to the reinforcement.
- The matrix must stand up to the service conditions, viz., temperature, humidity, exposure to ultra-violet environment, exposure to chemical atmosphere, abrasion by dust particles, etc.
- The matrix must be easy to use in the selected fabrication process.
- Smoke requirements.
- Life expectancy.
- The resultant composite should be cost effective.

The fibers are saturated with a liquid resin before it cures to a solid. The solid resin is then said to be the matrix for the fibers.

Advantages and Limitations of Composites Materials

Advantages of Composites

The advantages exhibited by composite materials, which are of significant use in aerospace industry are as follows:

- High resistance to fatigue and corrosion **degradation**.
- High ‘strength or stiffness to weight’ ratio. As enumerated above, weight savings are significant ranging from 25-45% of the weight of conventional metallic designs.
- Due to greater **reliability**, there are fewer inspections and structural repairs.
- Directional **tailoring capabilities** to meet the design requirements. The fibre pattern can be laid in a manner that will tailor the structure to efficiently sustain the applied loads.
- Fiber to fiber redundant load path.
- Improved dent resistance is normally achieved. Composite panels do not sustain damage as easily as thin gage sheet metals.
- It is easier to achieve smooth **aerodynamic profiles** for drag reduction. Complex double-curvature parts with a smooth surface finish can be made in one manufacturing operation.
- Composites offer improved **torsion stiffness**. This implies high whirling speeds, reduced number of intermediate bearings and supporting structural elements. The overall part count and manufacturing & assembly costs are thus reduced.
- High resistance to impact damage.
- Thermoplastics have rapid process cycles, making them attractive for high volume commercial applications that traditionally have been the domain of sheet metals. Moreover, thermoplastics can also be reformed.
- Like metals, thermoplastics have indefinite shelf life.
- Composites are **dimensionally stable** i.e. they have low thermal conductivity and low coefficient of thermal expansion. Composite materials can be tailored to comply with a broad range of thermal expansion design requirements and to minimize thermal stresses.
- Manufacture and assembly are simplified because of part integration (joint/fastener reduction) thereby reducing cost.
- The improved **weather ability** of composites in a marine environment as well as their corrosion resistance and durability reduce the down time for maintenance.

- Close tolerances can be achieved without machining.
- Material is reduced because composite parts and structures are frequently built to shape rather than machined to the required configuration, as is common with metals.
- Excellent heat sink properties of composites, especially Carbon-Carbon, combined with their lightweight have extended their use for aircraft brakes.
- Improved friction and wear properties.
- The ability to tailor the basic material properties of a Laminate has allowed new approaches to the design of **aero elastic flight structures**.

The above advantages translate not only into airplane, but also into common implements and equipment such as a graphite racquet that has inherent damping, and causes less fatigue and pain to the user.

Limitations of Composites

Some of the associated disadvantages of advanced composites are as follows:

- High cost of raw materials and fabrication.
- Composites are more brittle than wrought metals and thus are more easily damaged.
- Transverse properties may be weak.
- Matrix is weak, therefore, low toughness.
- Reuse and disposal may be difficult.
- Difficult to attach.
- Repair introduces new problems, for the following reasons:
 - Materials require refrigerated transport and storage and have limited shelf life.
 - Hot curing is necessary in many cases requiring special tooling.
 - Hot or cold curing takes time.
 - Analysis is difficult.
 - Matrix is subject to environmental degradation.

However, proper design and material selection can circumvent many of the above disadvantages.

New technology has provided a variety of reinforcing fibers and matrices those can be combined to form composites having a wide range of exceptional properties. Since the advanced composites are capable of providing structural efficiency at lower weights as compared to equivalent metallic structures, they have emerged as the primary materials for future use.

In aircraft application, advanced fiber reinforced composites are now being used in many structural applications, viz. floor beams, engine cowlings, flight control surfaces, landing gear doors, wing-to-body fairings, etc., and also major load carrying structures including the vertical and horizontal stabilizer main torque boxes.

Composites are also being considered for use in improvements to civil infrastructures, viz., earthquake proof highway supports, power generating wind mills, long span bridges, etc.

Comparison with Metals

Requirements governing the choice of materials apply to both metals and reinforced plastics. It is, therefore, imperative to briefly compare main characteristics of the two.

- Composites offer significant weight saving over existing metals. Composites can provide structures that are 25-45% lighter than the conventional aluminium structures designed to meet the same functional requirements. This is due to the lower density of the composites. Depending on material form, composite densities range from 1260 to 1820 kg/in³ (0.045 to 0.065 lb/in³) as compared to 2800 kg/in³ (0.10 lb/in³) for aluminium. Some applications may require thicker composite sections to meet strength/stiffness requirements, however, weight savings will still result.
- Unidirectional fibre composites have specific tensile strength (ratio of material strength to density) about 4 to 6 times greater than that of steel and aluminium.
- Unidirectional composites have specific -modulus (ratio of the material stiffness to density) about 3 to 5 times greater than that of steel and aluminium.
- **Fatigue endurance limit** of composites may approach 60% of their **ultimate tensile strength**. For steel and aluminium, this value is considerably lower.
- Fiber composites are more versatile than metals, and can be tailored to meet performance needs and complex design requirements such as **aero-elastic loading** on the wings and the vertical & the horizontal stabilizers of aircraft.
- Fiber reinforced composites can be designed with excellent structural **damping features**. As such, they are less noisy and provide lower vibration transmission than metals.
- High corrosion resistance of fiber composites contributes to reduce life- cycle cost.

- Composites offer lower manufacturing cost principally by reducing significantly the number of detailed parts and expensive technical joints required to form large metal Structural components. In other words, composite parts can eliminate joints/fasteners thereby providing parts simplification and integrated design.
- Long term service experience of composite material environment and **durability behavior** is limited in comparison with metals.