

CHEMISTRY

(20A51101T)

LECTURE NOTES

I-B. TECH & I-SEM

Prepared by:

T.V.Prathima , Assistant Professor

Department of Humanities & Sciences



VEMU INSTITUTE OF TECHNOLOGY

(Approved By AICTE, New Delhi and Affiliated to JNTUA, Anantapur)

Accredited By NAAC, NBA (EEE, ECE & CSE) & ISO: 9001-2015 Certified Institution

Near Pakala, Kothakota, Chittoor- Tirupati Highway

Chittoor, Andhra Pradesh-517 112

Web Site: www.vemu.org



R20 Regulations

JAWAHARLAL NEHRU TECHNOLOGICAL UNIVERSITY ANATAPUR
(Established by Govt. of A.P., ACT NO.30 OF 2008)
ANANTHAPURAMU – 515 002 (A.P) INDIA

HUMANITIES AND SCIENCES

Course Code		L	T	P	C
20A51101T	CHEMISTRY	3	0	0	3
Course Objectives:					
<ul style="list-style-type: none"> • To familiarize engineering chemistry and its applications. • To train the students on the principles and applications of electrochemistry and polymers. • To introduce instrumental methods, molecular machines and switches 					
Course Outcomes (CO): After completion of the course, the student can able to					
CO-1: Apply Schrodinger wave equation to hydrogen atom , Illustrate the molecular orbital energy level diagram of different molecular species , Explain the calculation of bond order of O ₂ and Co molecules .					
CO-2: Apply the principle of Band diagrams in application of conductors and semiconductors .					
CO-3: Compare the materials of construction for battery and electrochemical sensors .					
CO-4: Explain the preparation, properties, and applications of thermoplastics & thermosetting, elastomers & conducting polymers.					
CO-5: Explain the principles of spectrometry, slc in separation of solid and liquid mixtures.					
Unit- I: Structure and Bonding Models:					
Planck's quantum theory, dual nature of matter, Schrodinger equation, significance of Ψ and Ψ^2 , applications to hydrogen, molecular orbital theory – bonding in homo- and heteronuclear diatomic molecules – energy level diagrams of O ₂ and CO, etc. π -molecular orbitals of butadiene and benzene, calculation of bond order.					
Unit-II: Modern Engineering materials:					
Coordination compounds: Crystal field theory – salient features – splitting in octahedral and tetrahedral geometry. Properties of coordination compounds-Oxidation state, coordination, magnetic and colour. Semiconductor materials, super conductors- basic concept, band diagrams for conductors, semiconductors and insulators, Effect of doping on band structures. Supercapacitors: Introduction, Basic Concept-Classification – Applications. Nano chemistry: Introduction, classification of nanomaterials, properties and applications of Fullerenes, carbon nano tubes and Graphines nanoparticles.					
Unit-III: Electrochemistry and Applications:					
Electrodes – concepts, reference electrodes (Calomel electrode, Ag/AgCl electrode and glass electrode); Electrochemical cell, Nernst equation, cell potential calculations and numerical problems. potentiometry- potentiometric titrations (redox titrations), concept of conductivity, conductivity cell, conductometric titrations (acid-base titrations). Electrochemical sensors – potentiometric sensors with examples, amperometric sensors with examples. Primary cells – Zinc-air battery, Secondary cells – Nickel-Cadmium (NiCad), and lithium-ion batteries working of the batteries including cell reactions; Fuel cells, hydrogen-oxygen, methanol fuel cells – working of the cells.					
Unit – IV: Polymer Chemistry:					
Advanced Engineering Materials Composites: Definition, Constituents, Classification- Particle, Fiber and Structural reinforced composites, properties and Engineering applications Refractories- Classification, Properties, Factors affecting the refractory materials and Applications. Lubricants- Classification, Functions of lubricants, Mechanism, Properties of lubricating oils – Viscosity, Viscosity Index, Flash point, Fire point, Cloud point, saponification and Applications. Building materials- Portland Cement, constituents, phases and reactivity of clinker, Setting and Hardening of cement					
Unit-V: Instrumental Methods and Applications					
Electromagnetic spectrum. Absorption of radiation: Beer-Lambert's law. Principle and applications of pH metry, UV-Visible, IR Spectroscopies. Solid-Liquid Chromatography–TLC, retention time.					
Textbooks:					
1. Jain and Jain, Engineering Chemistry, 16/e, Dhan Patrai, 2013. 2. Peter Atkins, Julio de Paula and James Keeler, Atkins' Physical Chemistry, 10/e, Oxford University Press, 2010					
Reference Books:					
1. G.V. Subba Reddy, K.N. Jayaveera and C. Ramachandra, Engineering Chemistry, Mc Graw Hill, 2020. 2. Skoog and West, Principles of Instrumental Analysis, 6/e, Thomson, 2007. 3. D. Lee, Concise Inorganic Chemistry, 5/e, Oxford University Press, 2008. 4. J.M. Lehn, Supra Molecular Chemistry, VCH Publications					

UNIT-I: Structure and Bonding Models

Lecture notes

Planck's Quantum theory was proposed by Max Planck in 1900. This theory explains the nature of black body radiation.

Black Body Radiation:- When solids are heated, they emit radiation over a wider range of wavelengths.

Definition:- "An ideal body which can emit and absorb radiation of all frequencies is called *blackbody*". The radiation emitted by such bodies is called **black body radiation**.

Planck's Quantum Theory:-

When a blackbody is heated, it emits thermal radiation of different wavelengths (or) frequency. To explain these radiations, Max Planck put forward a theory known as Planck's quantum theory.

The main points of quantum theory are:

- The emission and absorption of the energy by an atom occurs in the form of radiation is not a continuous process.
- The emission and absorption of the energy by a body occurs in the form of pockets of energy is called quanta (or) photon.
- The emission and absorption of the energy by a body occurs in the form of pockets of energy is called quanta (or) photon.

$$E = h\nu$$

Where ν is the frequency of radiation and h is Planck's constant 6.626×10^{-27} erg.sec (or) 6.626×10^{-34} J.sec. A body can radiate (or) absorb energy in whole number multiples of a quantum $h\nu, 2h\nu, 3h\nu, nh\nu$.

$$\text{Where } \nu = \frac{C}{\lambda}$$

$$E = nhc / \lambda$$

Neils Bohr used this theory to explain the structure of atom. Thus, Planck's quantum theory was

able to explain the distribution of intensity of the radiation from black body as a function of frequency (or) wavelength at different temperatures.

Dual nature of an electron

In case of light some phenomenon like diffraction and interference can be explained on the basis of its **wave character**. However, the other phenomenon such as black body radiation and photoelectric effect can be explained only on the basis of its **particle nature**. Thus, light is said to have a dual character. Such studies on light were made by Einstein in 1905. Louis de Broglie, in 1924 extended the idea of photons to material particles such as electron and he proposed that matter also has a dual character as wave and as particle.

Particle character

The particle character of microscopic particles such as electrons can be verified by observing the scintillations produced upon their striking on a fluorescent screen.

Wave character

The wave character of microscopic particles such as an electron can be verified by the Davission and Germer experiment. The experiment was originally suggested to verify the wave character of an electron. In this experiment, a beam of electrons obtained from a heated filament is allowed to strike in a nickel crystal. The nickel crystal operates like a natural grating and a characteristic diffraction pattern is observed on a photographic plate placed behind the crystal. This experiment confirms that the electron is capable of exhibiting diffraction, which is characteristic of a wave.

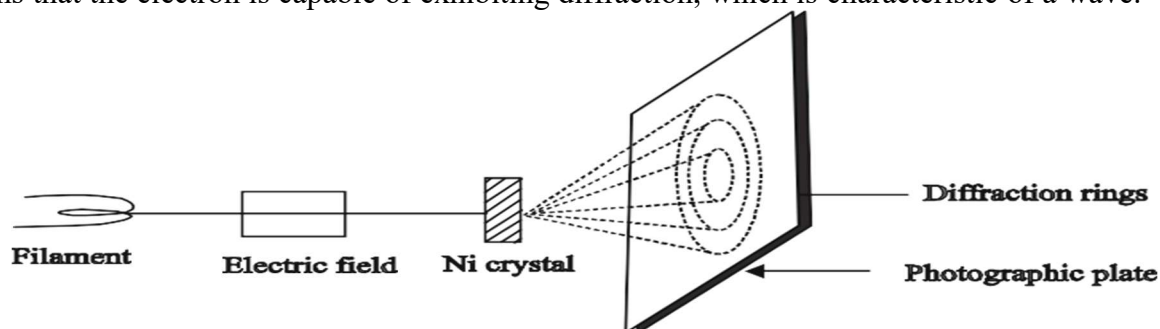

This is how it establishes the wave character of electrons.

Fig.1.1 Davission-Germer experimental setup

Schrodinger Wave Equation and significance of ψ and ψ^2 .

The Schrodinger wave equation can be derived from the classical wave equation as well as from the third postulate of quantum mechanics. Now though the two routes may appear completely different, the final result is just the same indicating the objectivity of the quantum mechanical system.

After the failure of the Bohr atomic model to comply with the Heisenberg's uncertainty principle and dual character proposed by Louis de Broglie in 1924, an Austrian physicist Erwin Schrodinger developed his legendary equation by making the use of wave-particle duality and classical wave equation. In order to understand the concept involved, consider a wave traveling in a string along the x-axis with velocity v.

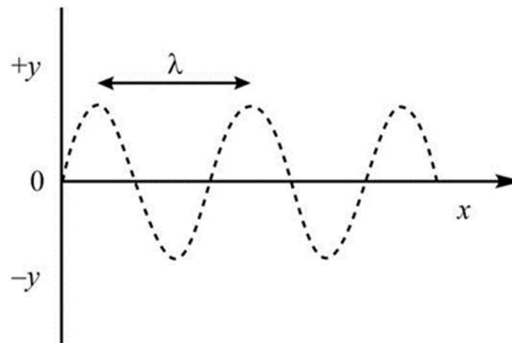

Figure 1. The wave motion in a string.

It can be clearly seen that the amplitude of the wave at any time t is the function of displacement x, and the equation for wave motion can be formulated as given below.

$$\frac{\partial^2 y}{\partial x^2} = \frac{1}{v^2} \frac{\partial^2 y}{\partial t^2} \quad (13)$$

Therefore, we can say that y is a function of x well at t.

$$y = f(x)f'(t) \quad (14)$$

Where f(x) and f'(t) are the functions of coordinate x and time, respectively. The nature of the function f(x) can be understood by taking the example of stationary or the standing wave.

A standing wave is created in a string fixed between two points with a wave traveling in one direction, and when it strikes the other end, it gets reflected with the same velocity but in negative amplitude. This would create vibrations in that string with or without nodes depending upon the

frequency incorporated. We can create fundamental mode (0 node), first overtone (1 node) or second overtone (2 nodes) just by changing the vibrational frequency. The nature of these standing or stationary waves can be understood more clearly by the diagram given below.

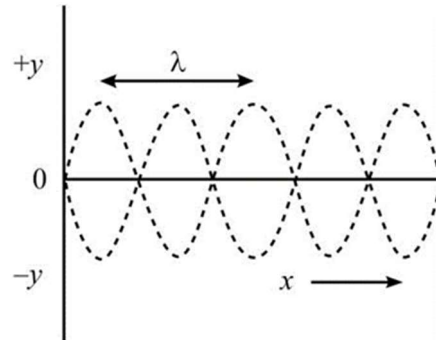

Figure 2. Standing waves in a string.

The mathematical description for such a wave motion is

$$f'(t) = A \sin 2\pi vt \quad (15)$$

Where A is a constant representing maximum amplitude and v is the frequency of the vibration. Now putting the value of $f'(t)$ from equation (15) in equation (14), we get

$$y = f(x) A \sin 2\pi vt \quad (16)$$

Differentiating the above equation w.r.t. t , we are left with

Differentiating the above equation w.r.t. t , we are left with

$$-\frac{\partial y}{\partial t} f(x) A 2\pi v \cos 2\pi vt \quad (17)$$

Differentiating again

$$-\frac{\partial^2 y}{\partial t^2} f(x) 4\pi^2 v^2 A \sin 2\pi vt \quad (18)$$

$$\frac{\partial^2 y}{\partial t^2} 4\pi^2 v^2 f(x) f'(t) \quad (19)$$

Now differentiating equation (14) w.r.t. x only, we get

$$-\frac{\partial y}{\partial x} \frac{\partial f(x)}{\partial x} = f'(t) \frac{\partial f(x)}{\partial x} \quad (20)$$

Differentiating again

$$\frac{\partial^2 y}{\partial x^2} = f'(t) \frac{\partial^2 f(x)}{\partial x^2} \quad (21)$$

Now put the value of equation (19) and (21) in equation (13), we get

$$\frac{\partial^2 f(x)}{\partial x^2} = \left(\frac{1}{v^2}\right) [-4\pi^2 v^2 f(x) f'(t)] \quad (22)$$

$$\frac{\partial^2 f(x)}{\partial x^2} = \frac{-4\pi^2 v^2}{v^2} f(x) \quad (23)$$

The equation (23) is now time-independent; and therefore, shows the amplitude dependence only upon the coordinate x . Since $c = v\lambda$ ($v = c/\lambda$), the velocity of the wave can also be replaced by the multiplication of frequency and wavelength i.e. $v = v\lambda$.

$$\frac{\partial^2 f(x)}{\partial x^2} = \frac{-4\pi^2 v^2}{v^2 \lambda^2} f(x) \quad (24)$$

$$\frac{\partial^2 f(x)}{\partial x^2} = \frac{-4\pi^2}{\lambda^2} f(x) \quad (25)$$

The symbol of the function $f(x)$ is replaced by popular $\psi(x)$ or simply the ψ .

$$\frac{\partial^2 \psi}{\partial x^2} = \frac{-4\pi^2}{\lambda^2} \psi \quad (26)$$

Also, as we know that $\lambda = h/mv$, the equation (26) becomes

$$\frac{\partial^2 \psi}{\partial x^2} = \frac{-4\pi^2 m^2 v^2}{h^2} \psi \quad (27)$$

$$\frac{\partial^2 \psi}{\partial x^2} + \frac{4\pi^2 m^2 v^2}{h^2} \psi = 0 \quad (28)$$

Furthermore, as the total energy (E) is simply the sum of the potential (V) and kinetic energy, we can say that

$$E = \frac{mv^2}{2} + V \quad (29)$$

$$mv^2 = 2(E - V) \quad (30)$$

After putting the value of mv^2 from equation (30) in equation (28), we get

$$\frac{\partial^2 \psi}{\partial x^2} + \frac{8\pi^2 m}{h^2} (E - V) \psi = 0 \quad (31)$$

For three-dimension i.e. $\psi(x, y, z)$, the above equation can be extended to following

$$-\frac{\partial^2 \psi}{\partial x^2} - \frac{\partial^2 \psi}{\partial y^2} - \frac{\partial^2 \psi}{\partial z^2} = \frac{8\pi^2 m}{h^2} (E - V) \psi = 0 \quad (32)$$

The above-mentioned second order differential equation i.e. equation (32) is our popular form of the Schrodinger wave equation.

significance of Ψ and Ψ^2 :

ψ is a wave function and refers to the amplitude of electron wave i.e. probability amplitude. It has got no physical significance. The wave function ψ may be positive, negative or imaginary.

$[\psi]^2$ is known as probability density and determines the probability of finding an electron at a point within the atom. This means that if:

- (i) is zero, the probability of finding an electron at that point is negligible.
- (ii) $[\psi]^2$ is high, the probability of finding an electron is high i.e. electron is present at that place for a long time.
- (iii) $[\psi]^2$ is low. the probability of finding an electron is low i.e. electron is present at that place for a shorter time.

Application of hydrogen atom in schrodinger wane equation:

The hydrogen atom, consisting of an electron and a proton, is a two-particle system, and the internal motion of two particles around their center of mass is equivalent to the motion of a single particle with a reduced mass. This reduced particle is located at r , where r is the vector specifying the position of the electron relative to the position of the proton. The length of r is the distance between the proton and the electron, and the direction of r and the direction of r is given by the orientation of the vector pointing from the proton to the electron. Since the proton is much more massive than the electron, we will assume throughout this chapter that the reduced mass equals the electron mass and the proton is located at the center of mass.

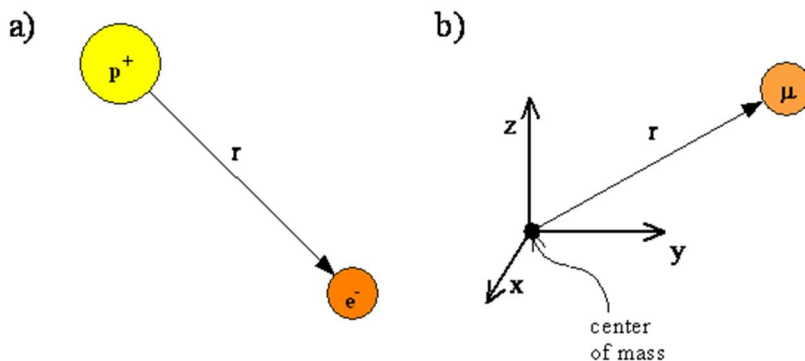

Figure 4.10.14.10.1: a) The proton (p^+) and electron (e^-) of the hydrogen atom. b) Equivalent reduced particle with reduced mass μ at distance r from center of mass.

Since the internal motion of any two-particle system can be represented by the motion of a single particle with a reduced mass, the description of the hydrogen atom has much in common with the description of a diatomic molecule discussed previously. The Schrödinger Equation for the hydrogen atom

$$\hat{H}(r,\theta,\phi)\psi(r,\theta,\phi)=E\psi(r,\theta,\phi)$$

employs the same kinetic energy operator, $\hat{T}\hat{T}$, written in spherical coordinates. For the hydrogen atom, however, the distance, r , between the two particles can vary, unlike the diatomic molecule where the bond length was fixed, and the rigid rotor model was used. The hydrogen atom Hamiltonian also contains a potential energy term, $\hat{V}\hat{V}$, to describe the attraction between the proton and the electron. This term is the Coulomb potential energy,

$$\hat{V}(r)=-\frac{e^2}{4\pi\epsilon_0 r} \quad (4.10.2) \quad \hat{V}(r)=-\frac{e^2}{4\pi\epsilon_0 r}$$

where r is the distance between the electron and the proton. The Coulomb potential energy depends inversely on the distance between the electron and the nucleus and does not depend on any angles. Such a potential is called a central potential.

It is convenient to switch from Cartesian coordinates x,y,z to spherical coordinates in terms of a radius r , as well as angles ϕ , which is measured from the positive x axis in the xy plane and may be between 0 and 2π , and θ , which is measured from the positive z axis towards the xy plane and may be between 0 and π .

Pi molecular orbitals of butadiene :

Butadiene is composed of 4 carbons with two adjacent Π bonds. These Π bonds are conjugated. All the four Π orbitals are aligned with each other and build up into a larger Π system. Since butadiene consists of 4 individual p orbitals, the Π system of butadiene will contain 4 Π molecular orbitals (containing 4 Π electrons). During filling the lowest energy molecular orbitals get filled first as shown in the diagram.

The molecular orbital diagram of butadiene shows two molecular orbitals.

1. Highest occupied molecular orbital.(HOMO)
2. Lowest unoccupied molecular orbital.(LUMO)

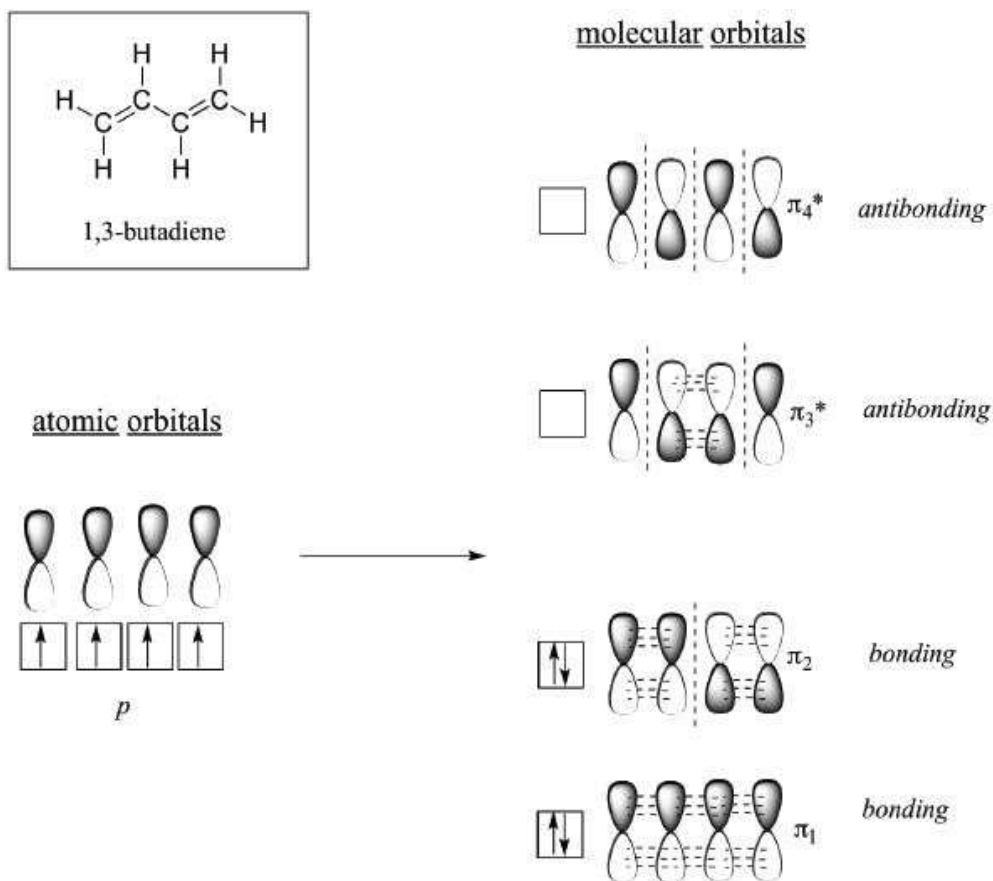

1.HOMO

HOMO is π_2 . It is the valence electrons of the π system. They will be lost readily. If butadiene participates in a reaction, where it is the electron-donor (nucleophile), its electrons are going to come from that orbital.

2.LUMO

LUMO is π_3^* . It is the lowest-energy unoccupied orbital. If butadiene participates in a reaction, where it is the electron acceptor (electrophile), the electrons will be donated to that orbital.

pi molecular orbital theory of benzene :

Benzene C_6H_6 is a planar molecule containing a ring of six carbon atoms, each with a hydrogen atom attached. All carbon-carbon bonds have the same lengths having single and double bonds. There is a delocalized electrons above and below the plane of ring. There are six p-orbital electrons that form the stabilizing electron clouds below and above the aromatic ring.

Molecular orbital description

We know that benzene has a planar hexagonal structure in which all the six carbon atoms are sp^2 hybridized. Of four valence electrons of each carbon atom, three forms covalent bonds with

two carbon and one hydrogen atoms. The remaining cyclic array of six p-orbitals (one on each carbon) overlap to generate six molecular orbitals, three bonding and three anti-bonding.

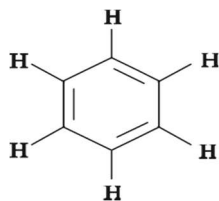

The plus and minus signs, shown in the diagram, do not represent electrostatic charge but refer to phase signs. When the phases, corresponds the orbitals, overlap to generate a common region of like phase, with those orbitals having greatest overlap (e.g., σ_1) being lowest in energy. The remaining carbon valence electrons then occupy these Molecular orbitals, in pairs, resulting in a fully occupied set of bonding molecular orbital

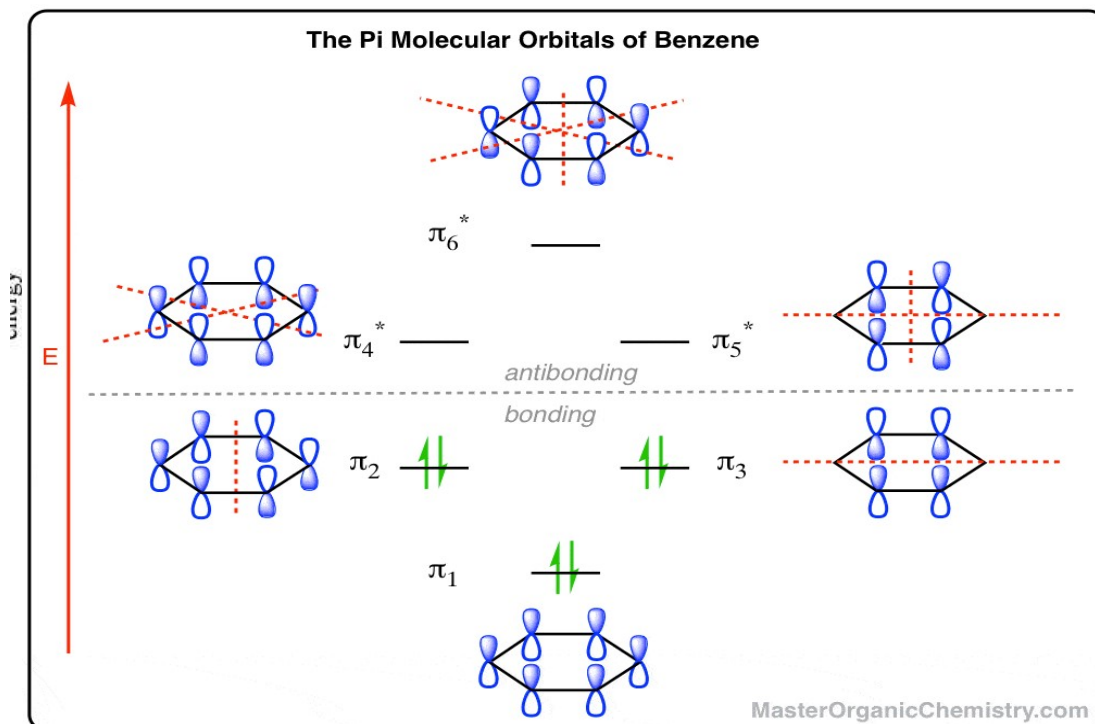

. De-Broglie's equation:

The wavelength of the wave associated with any material particle was calculated by analogy with photon. According to the Planck's quantum theory, If the photon has wave nature and its energy is given by,

$$E = h\nu \dots (1)$$

Where, ν is frequency of the wave and ' h ' is Planck's constant

According to Einstein's law of mass energy equivalence, If the photon is supposed to have particle nature, its energy is given by,

$$E = mc^2 \dots (2)$$

Where ' m ' is the mass of photon, ' c ' is the velocity of light.

From equation 1 and 2 we get,

$$h\nu = mc^2$$

But $v = c/\lambda$

$$hc/\lambda = mc^2 \text{ (or) } \lambda = h/mc$$

The above equation is applicable to material particle if the mass and velocity of photon is replaced by the mass and velocity of material particle.

Thus, for any material particle like electron

$$\lambda = h/mv \text{ (or) } \lambda = h/p$$

Where, p is the momentum of the particle

Heisenberg's Uncertainty Principle

Heisenberg's uncertainty principle states that for particles exhibiting both particle and wave nature, it will not be possible to accurately determine both the position and velocity at the same time. The principle is named after German physicist, Werner Heisenberg who proposed the uncertainty principle in the year 1927. This principle was formulated when Heisenberg was in trying to build an intuitive model of quantum physics. He discovered that there were certain fundamental factors that limited our actions in knowing certain quantities. This principle basically highlights that simultaneous measurement of position and the velocity or momentum of microscopic matter waves will have an error such that the product of the error in measurement of position and momentum is equal or more than an integral multiple of a constant., a particle with a well-defined wavelength will show a definitive or precise velocity. All in all, if we get an accurate reading of one quantity it will only lead to large uncertainty in the measurement of the other.

If Δx is the error in position measurement and Δp is the error in the measurement of momentum, then

$$\Delta X \times \Delta p \geq h/4\pi$$

Since momentum, $p = mv$, Heisenberg's uncertainty principle formula can be alternatively written as-

$$\Delta X \times \Delta p \geq h/4\pi$$

Or

$$\Delta X \times \Delta m \times \Delta v \geq h/4\pi$$

Where, ΔV is the error in the measurement of velocity and assuming mass remaining constant during the experiment,

$$\Delta X \times \Delta V \geq h/4\pi m.$$

Accurate measurement of position or momentum automatically indicates larger uncertainty (error) in the measurement of the other quantity.

Molecular orbital diagrams of Oxygen molecule (O₂) and Nitrogen molecule (N₂).
Explain their magnetic nature and bond order:

Molecular orbital diagrams of Oxygen molecule (O₂)

Oxygen molecule is formed from the combination of two O-atoms ($1s^2, 2s^2, 2p^2, 2p^1, 2p^1$). The outer shell of the O-atom

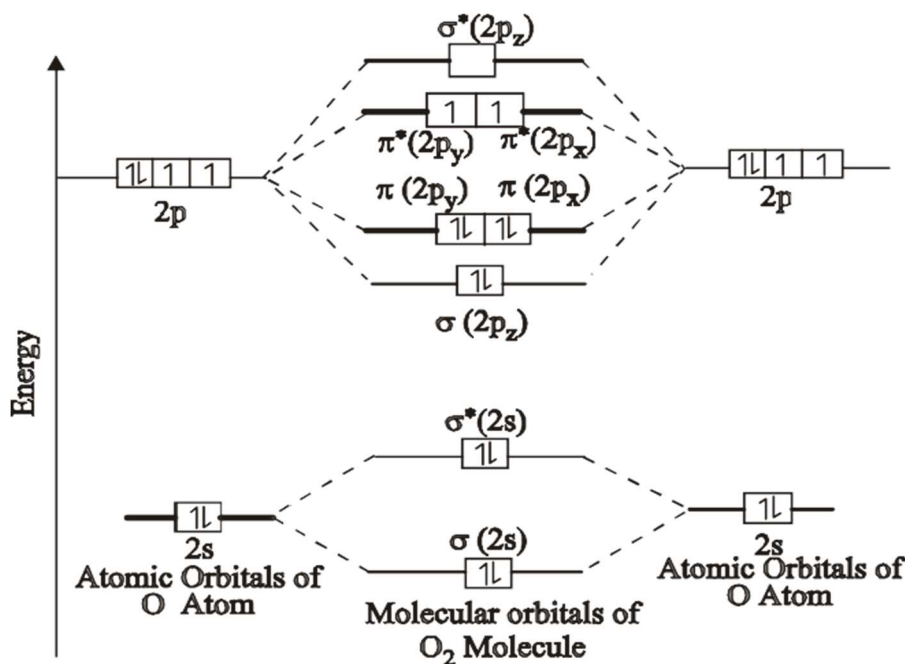

Fig: Molecular orbital diagram of O₂ molecule

The bond order in O₂:

$$\text{Bond order} = \frac{N_b - N_a}{2} = \frac{10 - 6}{2} = \frac{4}{2} = 2$$

where

a = Number of electrons in bonding molecular orbitals.

b = Number of electrons in antibonding molecular orbitals.

Thus, the two oxygen atoms are bonded through **two bonds** (one σ and other π). The molecule is **stable** and exists.

(i) Magnetic properties

According to Hund's rule, the last two electrons in $\pi(2p_y)$ and $\pi(2p_z)$ orbitals remain

unpaired. Therefore the molecule is **paramagnetic** due to the presence of two unpaired electrons.

Eg :- Molecular orbital diagrams of Nitrogen molecule (N₂)

Electronic configuration of N₂ (14 electrons) = $(\sigma 1s)^2(\sigma^* 1s)^2(\sigma 2s)^2(\sigma^* 2s)^2(\pi)^4(2p_z)^2$

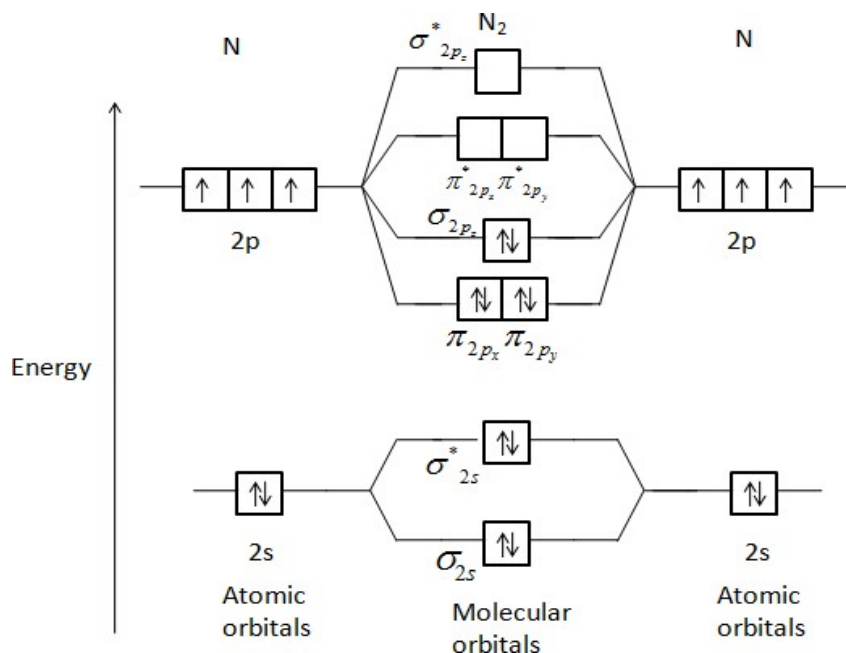

Fig: Molecular orbital diagram of N₂ molecule

The bond order in N₂

N (i) Bond order = $\frac{N_b - N_a}{2} = \frac{10 - 4}{2} = \frac{6}{2} = 3$
 where

a = Number of electrons in bonding molecular orbitals.

b = Number of electrons in antibonding molecular orbitals.

Thus, the two Nitrogen atoms are bonded through **three bonds** (one σ and other π). The molecule is **stable** and **exists**.

(ii) **Magnetic properties**

According to Hund's rule, all the electrons are paired Therefore the molecule is **dia-magnetic** due to the presence of paired electrons.

Energy level diagram of Carbonmonoxide(CO) and (NO). Explain its magneticproperty and bond order.

Carbon monoxide is formed from the combination of one C-atom and one O-atom. The outer shell of the C-atom($2s^2, 2p^2$)contains 4 electrons and O-atom ($2s^2, 2p^4$) contains 6 electrons in the outer shell.

Accordingly there are 10 electrons to be accommodated in the molecular orbitals of CO. The electronic configuration of CO molecule is represented by the equation.

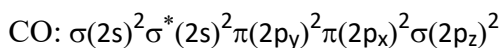
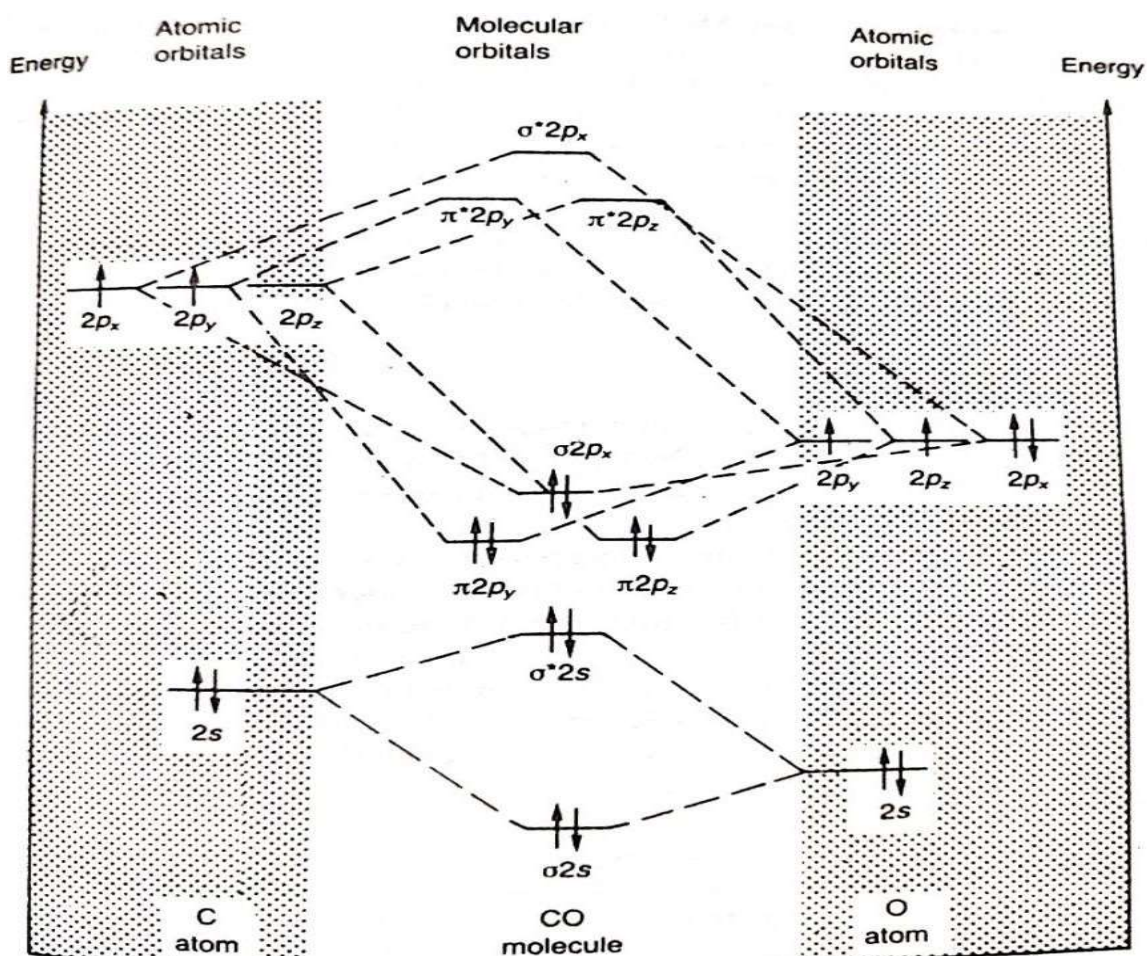

The molecular orbital energy level diagram for CO molecule is shown in fig.

(iii) The bond order in CO

$$\text{Bond order} = \frac{N_b - N_a}{2} = \frac{8 - 2}{2} = \frac{6}{2} = 3$$

Thus, the C-atom and O-atom are bonded through three bonds (one σ and two π).

(iv) Magnetic properties

Since non paired electron is present in CO molecule. It is **diamagnetic**.

Eg:- Molecular energy level diagram of NO;

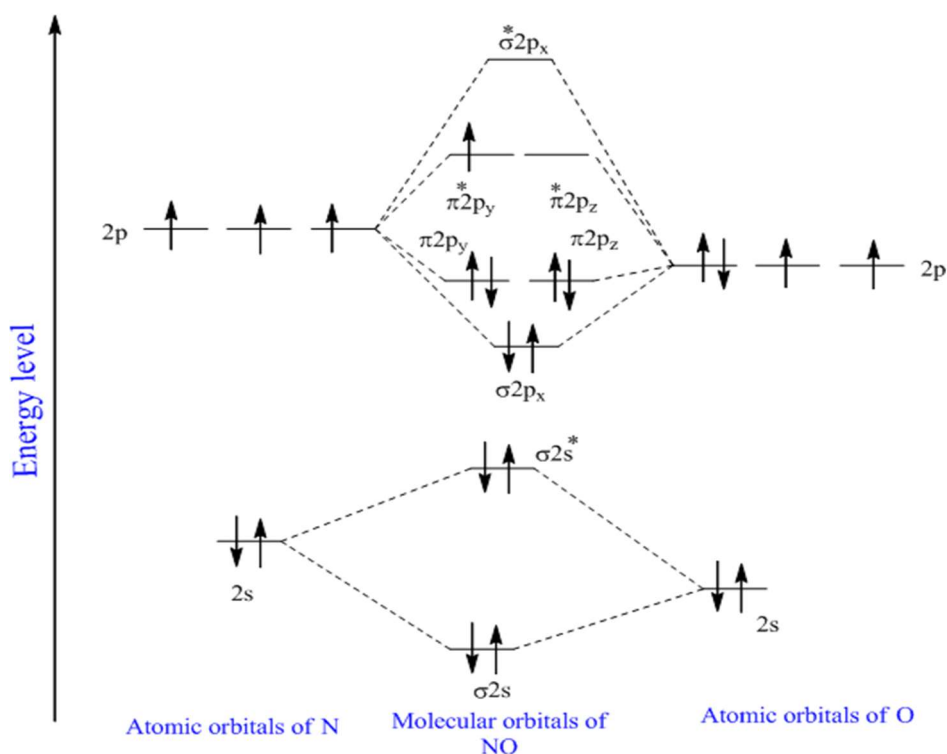

The molecular orbital energy level diagram for NO molecule is shown in fig.

(v) The bond order in NO

$$\text{Bond order} = \frac{N_b - N_a}{2} = \frac{10 - 5}{2} = \frac{5}{2} = 2.5$$

Thus, the N-atom and O-atom are bonded in ionic form.

(vi) Magnetic properties

Since unpaired electron is present in NO molecule. It is **Paraamagnetic**.

Postulates of molecular orbital theory:

The Molecular Orbital Theory (often abbreviated to MOT) is a theory on chemical bonding developed at the beginning of the twentieth century by F. Hund and R. S. Mulliken to describe the structure and properties of different molecules. The valence-bond theory failed to adequately explain how certain molecules contain two or more equivalent bonds whose bond orders lie between that of a single bond and that of a double bond, such as the bonds in resonance-stabilized molecules. This is where the molecular orbital theory proved to be more powerful than the valence-bond theory (since the orbitals described by the MOT reflect the geometries of the molecules to which it is applied).

The key features of the molecular orbital theory are listed below.

- The total number of molecular orbitals formed will always be equal to the total number of atomic orbitals offered by the bonding species.
- There exist different types of molecular orbitals viz; bonding molecular orbitals, anti-bonding molecular orbitals, and non-bonding molecular orbitals. Of these, anti-bonding molecular orbitals will always have higher energy than the parent orbitals whereas bonding molecular orbitals will always have lower energy than the parent orbitals.
- The electrons are filled into molecular orbitals in the increasing order of orbital energy (from the orbital with the lowest energy to the orbital with the highest energy).
- The most effective combinations of atomic orbitals (for the formation of molecular orbitals) occur when the combining atomic orbitals have similar energies.

In simple terms, the molecular orbital theory states that each atom tends to combine together and form molecular orbitals. As a result of such arrangement, electrons are found in various atomic orbitals and they are usually associated with different nuclei. In short, an electron in a molecule can be present anywhere in the molecule.

Molecular orbital theory approximation of the molecular orbitals as linear combinations of atomic orbitals can be illustrated as follows.

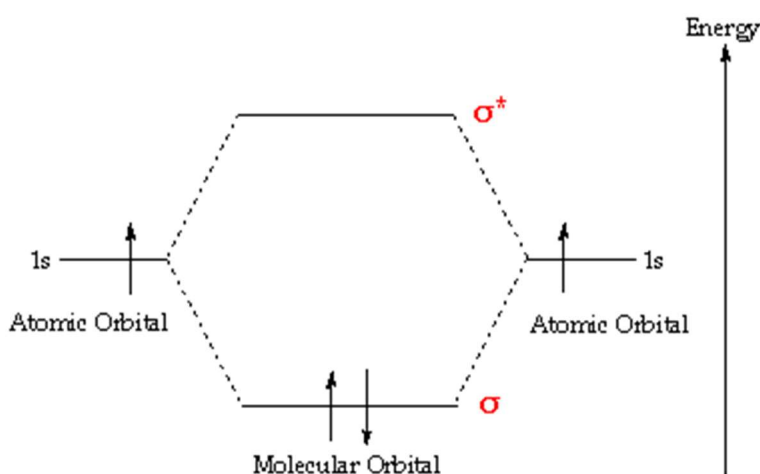

Differences between bonding and anti-bonding:

Bonding molecular orbitals

Antibonding molecular orbitals

- The molecular orbital formed by the constructive overlapping of atomic orbitals is called the bonding molecular orbital.
- In the bonding molecular orbitals, electrons density lies between the nuclei of bonded atom.
- The bonding molecular orbitals represent the shape of molecule.
- The molecular orbital formed by the destructive overlapping of atomic orbitals is called an antibonding molecular orbital.
- In the non bonding molecular orbitals, electrons density lies outside the nuclei of bonded atom.
- The non bonding molecular orbital does not contribute to shape of molecule.

UNIT-II: MODERN ENGINEERING MATERIALS

Lecture notes

Crystal field theory. crystal field splitting in octahedral and tetrahedral Complexes.

The crystal field theory considers that the central metal ion is surrounded by an electrical field caused by the ligands. The ligands may be negatively charged (like F^- , Cl^- , CN^- , etc.) or neutral molecule (like NH_3 , H_2O) but, must donate a pair of electrons to the metal ion. Thus due to the electrons belonging to the central metal ion and their interaction with the ligand electrons, an electrical field is developed. In the case of transition metals, this electrical field changes the energy of d-orbitals.

Grouping of d-orbitals into two sets

From the shape of d-orbitals, it is clear that, the d-orbitals are grouped into two set of orbitals

1. **Eg set of orbitals (dx^2-dy^2 , dz^2)**
2. **t_{2g} set of orbitals (dx_{yz} , dy_{zx} , dz_{xy}).** It is called triply degenerate set.

Salient features of CFT

1. The metal ion and the ligands act as point charges and the interaction between them is purely electrostatic, i.e., the metal-ligand bonds are 100% ionic.
2. A complex is considered as a combination of central metal ion surrounded by ligands.
3. There is no overlap of metal and ligand orbitals.
4. The d-orbitals of the metal atom which were of the same energy, i.e., degenerate and their degeneracy gets destroyed by ligands when a complex is formed.
5. The ligands in a complex are either negatively charged (or) neutral molecules which have dipole such that the negative end is closest to the central ion.
6. The interactions between the electrons of the metal and ligands is purely repulsive. These repulsive forces are responsible for the splitting of the d-orbitals of the metal ion into groups.
7. Different crystal fields will have different effects on the relative energies of the five d-orbitals.

Crystal Field Splitting Of D-Orbital In Octahedral Complexes

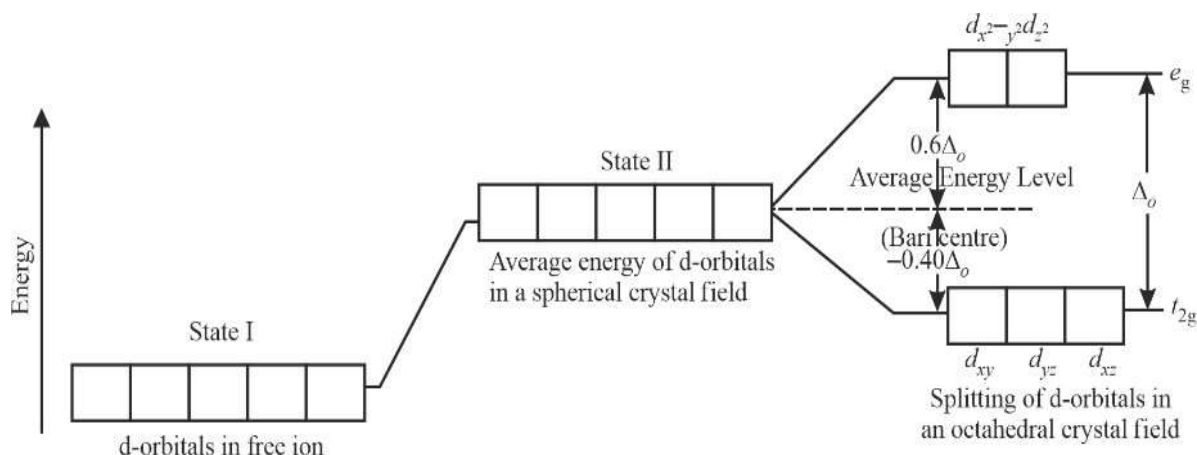

Splitting of d-orbitals in an octahedral crystal field

Fig : Crystal field splitting of d-orbitals in octahedral complexes.

Thus, the five d-orbitals, which are degenerate (equal energy) in the absence of any ligands, split into two sets of degenerate orbitals, t_{2g} and e_g orbitals, as shown in fig.

The difference in energy between these two sets of d-orbitals is called the **crystal field splitting** (Δ_o or $10Dq$), its magnitude depends on the metal and the nature of the ligands.

The gain in energy by preferential filling up of orbitals by electrons is known as **Crystal Field Stabilization Energy (CFSE)**. Greater the amount of CFSE of the complex, greater is its stability. The electrons pair up, since Δ_o is large enough to force them to do so and fill the t_{2g} orbitals.

Example: Crystal field splitting of $[\text{Fe}(\text{CN})_6]^{3-}$

In an octahedral complex of $[\text{Fe}(\text{CN})_6]^{3-}$ the central metal ion, Fe^{3+} , has the electronic configuration of $3d^5$. Since the cyanide ion (CN^-) is a strong field ligand, pairing of electrons takes place in the lower d-orbitals (t_{2g}) and so a **low-spin complex** is formed as shown in the figure.

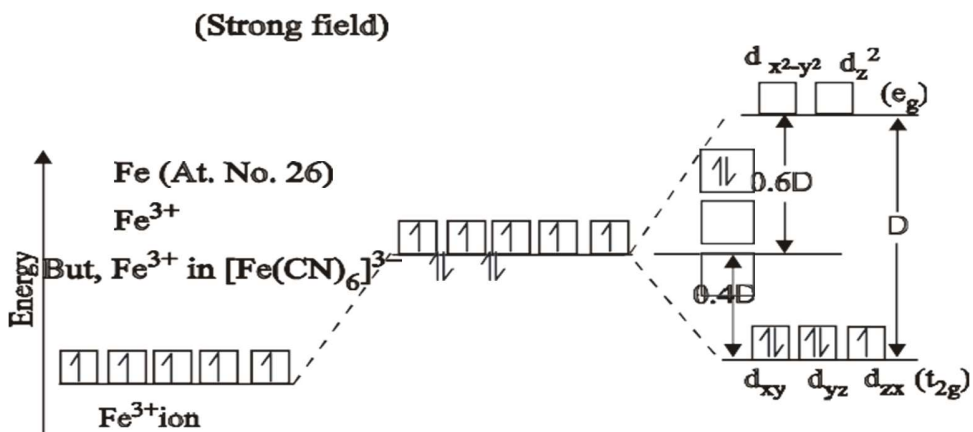

Fig.1.15 Crystal field splitting of [Fe (CN) 6]³⁻ complex

Since the complex has one unpaired electron in the t_{2g} orbital this complex is **paramagnetic**.

Crystal Field Splitting Of D-Orbital In Tetrahedral Complexes

In the tetrahedral complex, the metal ion is not in the centre of cube and the four **alternate corners** of the cube are occupied by four ligands as shown in fig 1.16. The directions of x, y and z axes point to the **centres of the faces** of the cube.

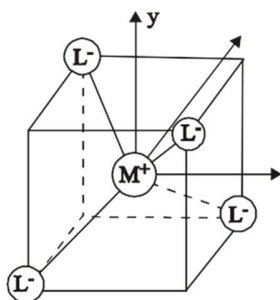

Fig : Arrangement of ligands in tetrahedral complex

We know that the lobes of e_g orbitals point along x, y and z axes (ie., towards the centres of the faces), while the lobes of t_{2g} orbitals point between x, y and z axes (ie., towards the centres of the edges of the cube).

(Weak field)

Since chloride ion (Cl^-) is a weak field ligand, it can't force the electrons to pair up in the lower d-orbitals (e_g) and so **high spin complex** is formed as shown in the fig.1.18.

Magnetic properties

Since the complex has three unpaired electrons in the t_{2g} orbital, this complex is **paramagnetic**.

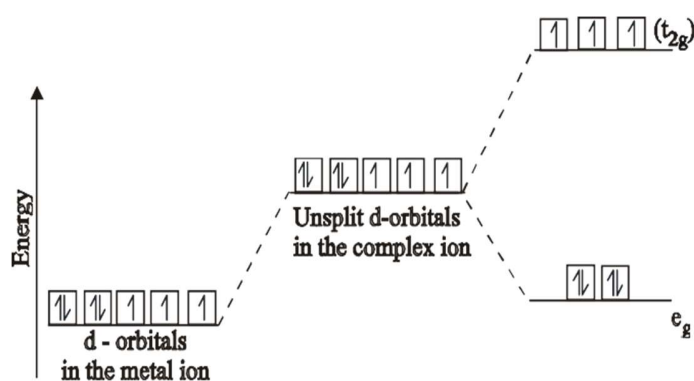

Fig1.18 Crystal field splitting of $[\text{CoCl}_4]^{2-}$ complex

From a knowledge of μ value and the unpaired electrons

- (i) the valence state of the central metal ion in octahedral complex
- (ii) the nature of bonding (i.e., whether the complex is high spin (or) low spin) can be known.

Draw the shapes of various d orbitals and explain why they are splitted in to two groups in an octahedral ligand field.

From the shape of d-orbitals, it is clear that, the d-orbitals are grouped into two set of orbitals.

- (i) E_g set of orbitals (d^2 and $d^2_{z^2-x^2-y^2}$). It is called doubly
- (ii) t_{2g} set of orbitals (d_{xy}, d_{yz}, d_{zx}). It is called triply degenerate set.

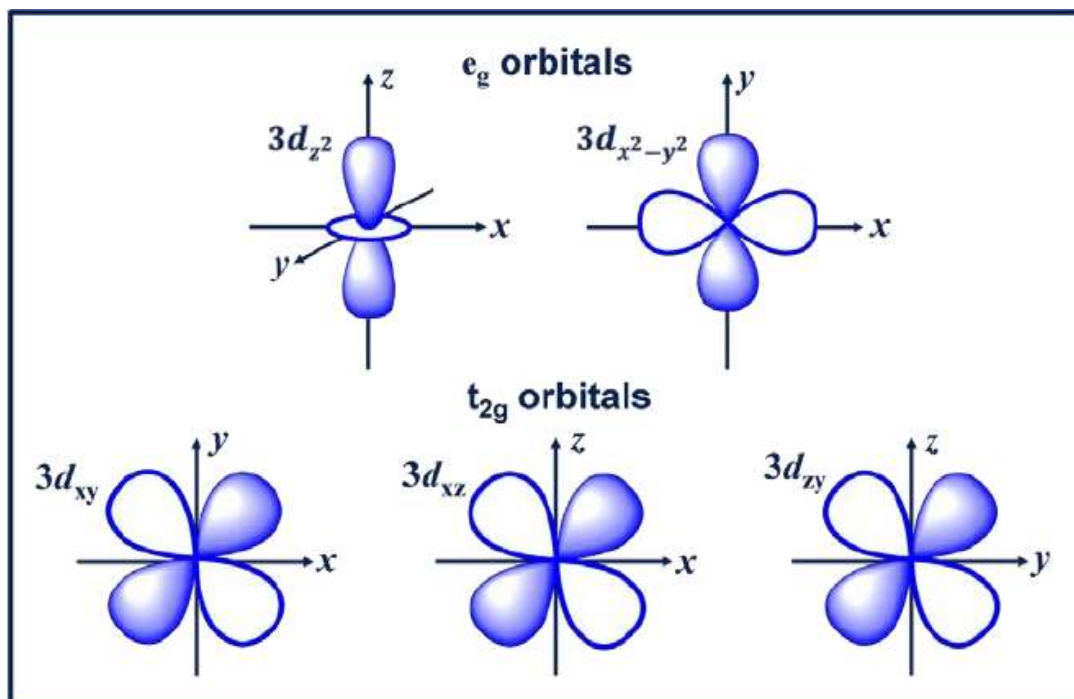

Fig: Grouping of d-orbitals

Explanation

The lobes of d_{xy} , d_{yz} , and d_{xz} orbitals are situated somewhat between the axes, whereas the lobes of $d_{x^2-y^2}$ and d_{z^2} orbitals are more concentrated on the axis. Thus when a ligand approaches the central metal ion along the axis, $d_{x^2-y^2}$ and d_{z^2} orbitals will be more affected and suffer larger repulsion than the d_{xy} , d_{yz} and d_{xz} orbitals, because of the greater interaction of $d_{x^2-y^2}$.

Properties of Coordination Compounds:

The general properties of coordination compounds are.

- The coordination compounds formed by the transition elements are coloured due to the presence of unpaired electrons that absorb light in their electronic transitions. For example, the complexes containing Iron(II) can exhibit green and pale green colours, but the coordination compounds containing iron(III) have a brown or yellowish-brown colour.
- When the coordination centre is a metal, the corresponding coordination complexes have a magnetic nature due to the presence of unpaired electrons.

- Coordination compounds exhibit a variety of chemical reactivity. They can be a part of inner-sphere electron transfer reactions as well as outer-sphere electron transfers.
- Complex compounds with certain ligands have the ability to aid in the transformation of molecules in a catalytic or a stoichiometric manner.

BASIC PRINCIPLE OF SEMICONDUCTORS:

The chemical bond in semiconductors is primarily covalent, which is quite different from metallic bond. When the atoms are brought near to each in the solid, the splitting of the energy levels produces two bands and they do not overlap. The conduction band lies higher in energy and is not occupied with electrons at 0 k. The valence band lies lower in energy and is filled electrons at 0 k. The energy splitting between the top of the valence band and the bottom of the conduction band is called the energy gap (E_g). The valence band of semiconductor is full and the conduction band is empty at 0 k. The energy separating the valence and conduction bands is the intrinsic energy gap, $E_g = (E_c - E_v)$. Figure shows the Energy level difference at different energies.

- a) An Intrinsic semiconductor with an energy gap of E_g , a valence band of E_v and a conduction band of E_c .
- b) Extrinsic semiconductor (Doped) with donor level E_d and acceptor level E_a .

If the semiconductor having impurity (dopant) atoms, energy states can exist in between the conduction band (E_c) and the valence band (E_v). If an atom contains one more valence electron than the semiconductor atom will occupy in the lattice only but not used in bonding. Instead of using in bond formation, this electron would be localized on the impurity atom and have an energy (E_d) just below that of the conduction band (E_c). For example, phosphorus atom doped with silicon type. This type of impurity is known as donor and the semiconductor is referred to as an n-type. In contrast to n-type semiconductor, an impurity atom with one less valence electron than the semiconductor atom will act as a hole (this may be filled with an electron) with an energy level (E_a) just above the valence band. Suitable example under this category is aluminum atom in silicon. This kind of impurity or dopant is called an acceptor or a p-type semiconductor. These dopant atoms dramatically change and improve the semiconductor's conductivity. In the case of InSb crystal, Sb atom act as donor and In atom act as acceptor. Hence, p or n-type semiconductor can be produced.

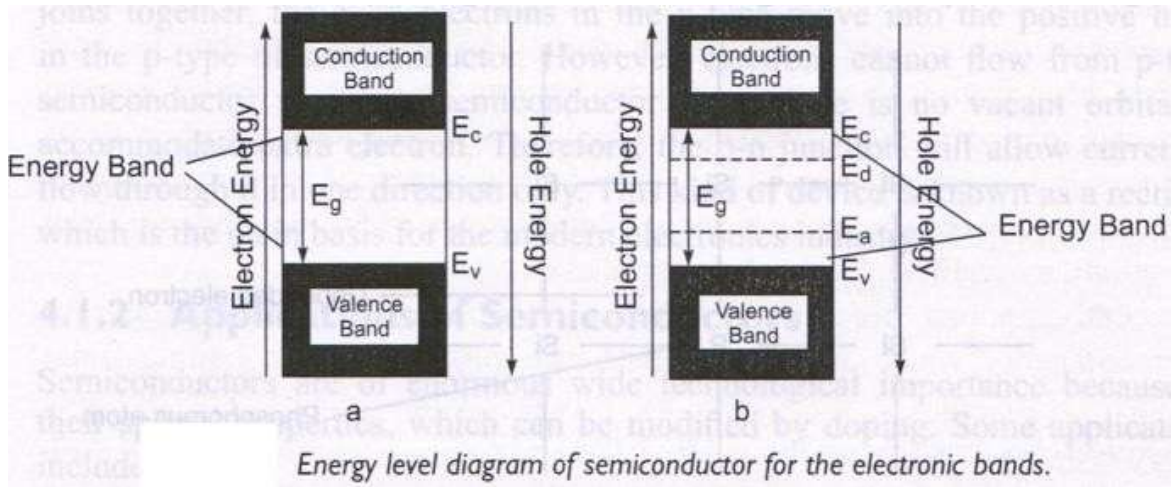

DOPING

Addition of trace amounts of other elements to a semiconductor lead to increase the conductivity of the materials is called doping. There are two kinds of doing techniques to get in n-type or p-type semiconductors. By considering silicon is an example, to illustrate n-type and p-type semiconductors.

n-type Semiconductors: In this type of semiconductors, add trace amounts of phosphorus to silicon. As per electronic configuration, phosphorus has five outer most electrons so there is one left over once the bonds formed with silicon. This extra or nonbonding electron can move freely through the lattice to increase the conductivity of silicon. The extra electron between the P and Si creates a small negative charge in that area hence the name **n-type** (n-stands for negative). The pictorial diagram is shown in figure.

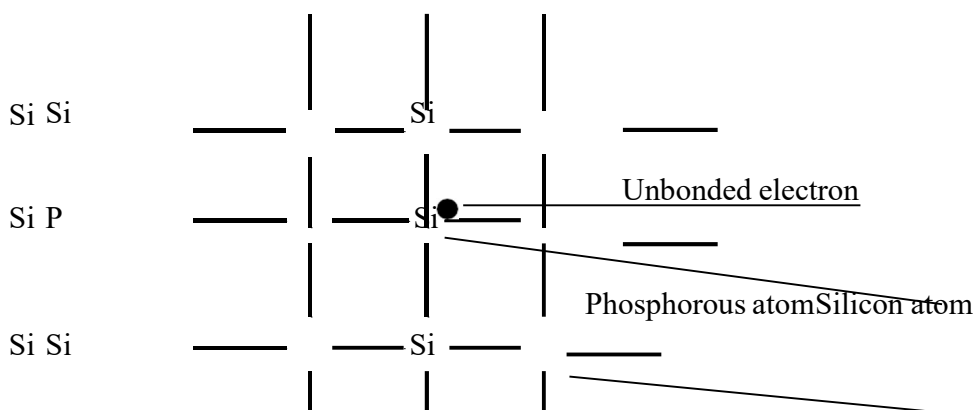

p-type Semiconductors: This type of semiconductors produced with the addition of small amounts of Boron to Silicon. Boron electronic configuration shows, it has three outer electrons

which are insufficient to make four bonds with Silicon. One electron on silicon is left over and is found nonbonding electron. This extra electron can move freely through the crystal lattice to increase the conductivity of the silicon. The lack of an electron between the boron and silicon atoms creates a small positive charge in that area and is often called as positive hole, hence the name of p-type semiconductor. The diagrammatic representation is shown in figure

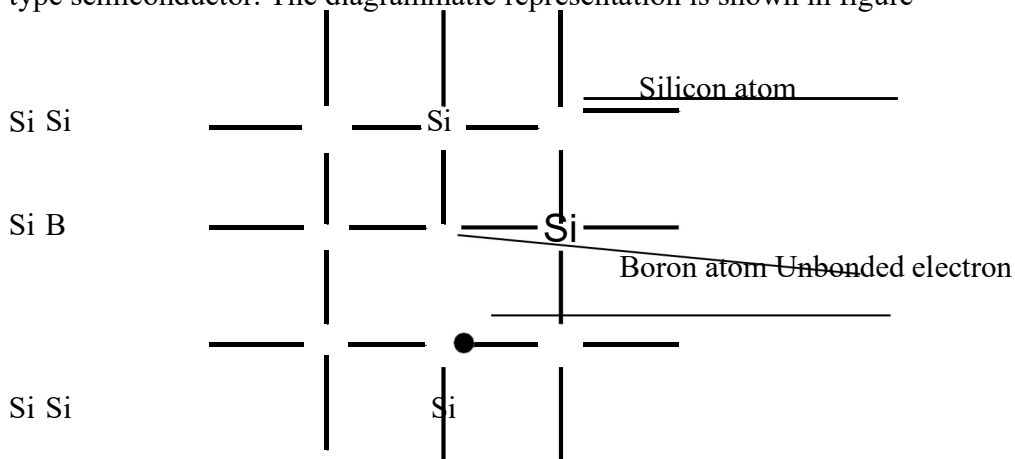

One of the main applications of n-type and p-type semiconductor was making of rectifier. It is noting that if an n-type and p-type semiconductor joins together, the extra electrons in the n-type move into the positive holes in the p-type of semiconductors. However, electrons cannot flow from p-type semiconductor to n-type semiconductor since there is no vacant orbital to accommodate extra electron. Therefore, the p-n junction will allow current to flow through it in one direction only. This kind of device is known as a rectifier, which is the main basis for the modern electronics industry.

APPLICATIONS OF SEMICONDUCTORS

Semiconductors are of enormous wide technological importance because of their special properties, which can be modified by doping. Some applications include:

1. Semiconductors are the foundation for modern electronics which includes radio, computers, and telephones.
2. Semiconductor-based electronics components employed in various applications including transistors, solar cells, light-emitting diodes (LEDs), and digital and analog integrated circuits.

3. The resistivity of semiconductors changes with temperature. On the basis of this, semiconductors enable to be used as thermometers.
4. Semiconductors are used in making of Hall Probes. These are measure magnetic field strengths with a small piece of semiconductor with known properties.
5. IR Sensors/Optoelectronic devices are made using semiconductors. Optoelectronic devices are capable of recognizing or responding to light of different wavelengths. This is called a phenomenon of photoconductivity whereby a semiconductor can greatly increase its electrical conductivity if the radiation energy has resonance with band gap energy can able to promote electrons across the band gap. Various semiconductors are available with different band gaps to suit particular applications.

SUPERCONDUCTORS

Most of the conductors lose all of their electrical resistance when cooled to very low temperatures which is near to absolute zero or $-273^{\circ}\text{Celsius}$. Superconductors are materials that show almost zero electrical resistance at temperatures near 0 Kelvin. The threshold conductor for superconductor to switchover from normal conduction to superconductivity is called the **transition temperature**. Transition temperatures for classic superconductors are in the cryogenic range i.e., near to absolute zero. Hundreds of materials are known to become superconductors at low temperatures. At low temperatures and low pressure, nearly 27 chemical elements, in which all of them metals are considered as superconductors with their normal crystallographic forms. Among these the common known metals are: aluminium, tin, lead, and mercury and less common ones such as rhenium, lanthanum and protactinium. Further, 11 elements which are metals, semimetals and semiconductors are superconductors at low temperatures and high pressures. Examples of such elements are uranium, cerium, silicon, and selenium. Bismuth and five other elements are not superconducting with their normal crystallographic form, can be made superconducting in a highly disordered form, which is stable at extremely low temperatures. Most of the known superconductors are alloys or compounds. **Superconductivity is not exhibited by any of the magnetic material chromium, manganese, iron, cobalt and nickel.**

Recently enough progress have been observed in the developments of superconductors which have zero resistance just above the boiling point of liquid Nitrogen (77 K) which are less costly to achieve. For example $\text{YBa}_2\text{Cu}_3\text{O}_7$ becomes superconducting below 92K. C_{60} (Fullerenes) doped with potassium and Rubidium is exhibits superconducting at these more manageable temperatures. Ideally, a superconductor should be able to operate within the range of ambient temperatures. The critical temperatures for a few common substances are shown here in this table.

Typical critical temperature of some of the materials

Material	Element/Compound/Alloy	Critical Temperature K
Aluminium	Element	1.02
Cadmium	Element	0.56
Lead	Element	7.2
Mercury	Element	4.16
Niobium	Element	8.70
Thorium	Element	1.37
Tin	Element	3.72
Titanium	Element	0.39
Uranium	Element	1.0
Zinc	Element	0.91
Niobium/Tin	Alloy	18.1
Cupric Sulphide	Compound	1.60

APPLICATIONS OF SUPERCONDUCTORS

The following are important applications of superconducting materials:

1. A superconducting material widely used in the construction of electromagnetic materials is an alloy of niobium and titanium. Hence these materials may employ in a wide variety of applications, ranging from electric power transmission to high-speed computing.
2. High-temperature superconductors are many applications in metrology, electromagnetic sensing, and analog and digital circuits.
3. Superconductors are also able to maintain a current with no applied voltage. This property used in superconducting electromagnetic materials found in MRI machines. Experiments have illustrated that currents in superconducting coils can persist for many years without any noticeable degradation. Experiment evidence reveals that current lifetime or superconducting at least 100,000 years.

4. Niobium-titanium (Nb Ti) alloy used in industrially as superconductor wire for superconducting magnets, normally as Nb-Ti fibers in an aluminium or copper matrix.
5. Niobium superconducting alloys, also containing titanium and tin are widely used in the superconducting magnets of MR/NMRI scanners.
6. Niobium-titanium superconducting magnet coils under liquid helium cooled were built to be used in the Alpha Magnetic Spectrometer mission to be flown on the international space station.

DOPING

Addition of trace amounts of other elements to a semiconductor lead to increase the conductivity of the materials is called doping. There are two kinds of doing techniques to get in n-type or p-type semiconductors. By considering silicon is an example, to illustrate n-type and p-type semiconductors.

If the semiconductor having impurity (dopant) atoms, energy states can exist in between the conduction band (E_c) and the valence band (E_v). If an atom contains one more valence electron than the semiconductor atom will occupy in the lattice only but not used in bonding. Instead of using in bond formation, this electron would be localized on the impurity atom and have an energy (E_d) just below that of the conduction band (E_c). For example, phosphorus atom doped with silicon type. This type of impurity is known as donor and the semiconductor is referred to as an n-type. In contrast to n-type semiconductor, an impurity atom with one less valence electron than the semiconductor atom will act as a hole (this may be filled with an electron) with an energy level (E_a) just above the valence band. Suitable example under this category is aluminum atom in silicon. This kind of impurity or dopant is called an acceptor or a p-type semiconductor. These dopant atoms dramatically change and improve the semiconductor's conductivity. In the case of In Sb crystal, Sb atom act as donor and In atom act as acceptor. Hence, p or n-type semiconductor can be produced.

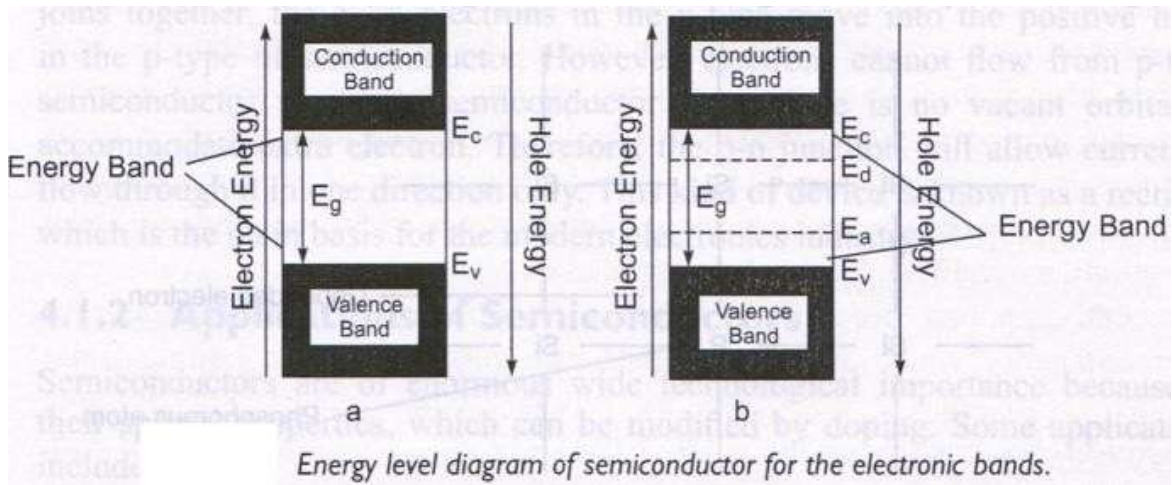

Nanomaterials:

Properties of Nanomaterials.

Properties of Nanomaterials.

The properties of Nanomaterials depends on size crystal structure and surface a characteristics

a) Size

Nano crystals have a large surface area, size of crystal is important for available active surface area.

b) Catalytic Activity

Catalytic Activity of nano particles in the form of colloids and nano clusters have been investigated in a wide variety of reaction in homogeneous phase and heterogeneous phase .

Ex- Rhodium- hydrogenation of olefins.

Palladium –reduction of nitriles and nitro arenes.

c) Electrical properties

Nano materials show electrical properties vary between semiconducting to metallic depending upon the chirality and diameter.

Ex- Nanotubes of MoS₂, WS₂.

d) Mechanical Properties

Nano materials possesses stiffness and strongest fibers known.

e) Optical properties

Nano materials that are provided large surface area exhibit better optical properties.

Ex-Silicon nano wires-Photoluminescence.

f) Semiconductors

Most of the nano materials exhibit semi conductivity propertiesEx-carbon

nanotubes and nano wires.

g) Super conductors

There are some nanomaterialswhich show superconductivity propertyEx-NbSe₂

becomes a super conductor at low temperature.

Insulators.

Characteristics of a Good Insulating Material:

A good insulating material has to possess the following characteristics:

1. Extremely high insulation resistance.
2. High dielectric strength.
3. Low thermal expansion.
4. Non-inflammable when exposed to arcing.
5. Resistant to oils or liquids, gas fumes, acids and alkalies.
6. Should have no deteriorating effect on the material, in contact with it.
7. Good thermal conductivity.
8. High mechanical strength
9. High thermal strength.
10. Should be resistant to thermal and chemical deterioration.
11. Should be resistant to moisture absorption.

Classification of Insulating material and their applications.

Classification of Insulating Materials:

The insulating materials can be classified in the following two ways:

1. Classification according to substances and materials.
2. Classification according to temperature.

1. Classification According to Substances and Materials:

(i) Solids (Inorganic and Organic):

Mica, wood, slate, glass, porcelain, rubber, cotton, silk, rayon, terylene, paper and cellulose materials etc.

(ii) Liquids (Oils and Varnishes):

These are mainly used for pure dielectric purpose to eliminate air or other gases particularly as an insulating and heat transfer medium.

Simple gases-

Gases like air and nitrogen are considered as insulating materials.

Nanomaterials and classification of Nanomaterials:

Material with any external dimension in the nanoscale or having internal structure or surface structure in the nanoscale", with *nanoscale* defined as the "length range approximately from 1 nm to 100 nm"

Classification:

Nanomaterials are classified into three types

one-dimensional nanomaterials (1D)-, materials with one dimension nanoscale. This class includes nanotubes, nanorods, and nanowires.

Two-dimensional nanomaterials (2D),-materials with two dimensions are outside the nanoscale. This class exhibits plate-like shapes and includes graphene, nanofilms, nanolayers, and nanocoatings.

Three-dimensional nanomaterials (3D) are materials that are not confined to the nanoscale in any dimension. This class can contain bulk powders, dispersions of nanoparticles, bundles of nanowires, and nanotubes as well as multi-nanolayers

small molecule asymmetric catalysts, this article focuses primarily on large catalytic host molecules. Non-discrete and structurally poorly defined system such as micelle and dendrimers are not included.

Carbon Nano Tubes.

carbonnanotube (CNT) :

A carbonnanotube (CNT) is one of the most important nanomaterials. Before 1991, only two main allotropes of carbon were known. In 1991, a Japanese physicist, SumioIizima invented CNT (another allotrope of carbon). Let us discuss the carbon nanotubes definition, carbon nanotube is a hollow tube made up of carbon of nanoscale diameter. In short, it is represented asCNTs. Carbon nanotubes are also called buckytube.

Nanotubes are formed by folding or rolling two-dimensional graphite into a cylindrical shapestructure. Nanotubes are hollow from inside. The diameter of the nanotube is around 1-3 nanometers. The length of the carbon nanotube is much higher than its diameter. Nano tube length generally goes to a few micrometers. In short, we can say that carbon nan (CNT) is a folded form of the two-dimensional graphene sheet. CNT (carbon nanotubes) exhibit extraordinary mechanical properties.

Types of Carbon Nanotubes

1. Single-walled Carbon nanotubes
2. Multi-walled Carbon nanotubes

Single-walled Carbon Nanotubes- it is represented as SWCNT. The Single-walled Carbon nanotubes exist in a 1-d structure. Some examples of Single-walled CNT are armchair and zig-zag Single-walled Carbon nanotubes

Properties of Single-walled Carbon Nanotubes are:

- The diameter of Single-walled Carbon nanotubes is 2nm.
- The length of Single-walled Carbon nanotubes is around 2 micrometres.
- They exist in a one-dimensional structure. Therefore, it is also known as a nanowire.
- Electronics can be miniaturized by using a Single-walled Carbon nanotube.
- Their band gap varies from 0-2 electron volts (eV).
- They show conductivity like a semiconductor. Therefore, they exhibit both metallic andsemi conductivity behaviour.

Fullerenes:

Fullerene is one of the allotropic forms of the carbon. The other name of fullerene is buckminsterfullerene. In this allotropic form of carbon, the carbon molecules are arranged in a series and form a cage like structure. This structure of fullerene is hollow in nature.In this allotropic form when the carbon molecules are arranged in a cylindrical form, they form a tube like structure. These tube-like structures are known as [carbon nanotubes](#).

Fullerene Structure

In nature, fullerenes, especially the C₆₀ sphere, are highly symmetrical. Fullerenes have a similar structure to graphite, which is made up of a sheet of connected hexagonal rings, but they have pentagonal (or sometimes heptagonal) rings that prevent the sheet from being planar. Buckyballs and buckytubes are terms used to describe them depending on their shape. Cylindrical fullerenes are referred to as nanotubes.

C₆₀ is the most common fullerene, with no two pentagons sharing an edge. A C₆₀ molecule's average carbon-carbon bond length is 1.44 angstrom.

Properties of Fullerene

Physical Properties of Fullerene

- Fullerene shows variation in behaviour and structure on changing the temperature. At a higher temperature the fullerene is converted into the C₇₀ form.
- Fullerene shows change in structure under different pressures.
- The ionization enthalpy of fullerene is 7.61 electron volts.
- The electron affinity of fullerene is 2.6 to 2.8 electrons volts.

Chemical Properties of Fullerene

- Fullerene (C₆₀) resembles an [electrophile](#) in the chemical reactions.
- Fullerene can act as an electron acceptor group. It can easily accept three electrons or more. Therefore, it can behave as an oxidizing agent.
- Fullerenes are doped with the alkali or alkaline earth metals, so that it can exhibit superconductivity properties.
- Ferromagnetism is a property of fullerene.
- Carbon molecules abound in fullerene. As a result, it's very soluble in organic solvents.

Types of Fullerene

1. Buckminsterfullerene
2. Endohedral Fullerene
3. Herbal fullerenes
4. Buckyball Clusters
5. Nanotubes
6. Megatubes
7. Linked bucky ball and chain Dimers
8. Herbal fullerenes

Some of the Forms of Fullerenes are Discussed Below:

Buckyball Clusters

These forms of fullerenes are the smallest member of the fullerene group. Its structural formula is C₂₀.

These fullerenes are unsaturated versions of dodecahedra.

Nanotubes

These forms of fullerene are hollow tubes of very small dimensions, having single or multiple walls.

These types of fullerenes play an important role in the electronics industry.

Megatubes

These are larger in diameter than the nanotubes. These types of fullerenes are prepared with walls of different thickness. It is potentially used for the transport of a variety of molecules of different sizes.

Linked Ball and Chain Dimer

In this form of fullerene, two buckyballs are linked by a carbon chain.

Buckminsterfullerene

Buckminsterfullerene is the most common form of the fullerene. It exists in C₆₀ form.

Graphene:

Graphene is a one-atom-thick layer of carbon atoms arranged in a hexagonal lattice. It is the building-block of Graphite (which is used, among other things, in pencil tips), but graphene is a remarkable substance on its own - with a multitude of astonishing properties which repeatedly earn it the title of wonder material.

Graphene's properties

Graphene is the thinnest material known to man at one atom thick, and also incredibly strong - about 200 times stronger than steel. On top of that, graphene is an excellent conductor of heat and electricity and has interesting light absorption abilities. It is truly a material that could change the world, with unlimited potential for integration in almost any industry

Potential applications

Graphene is an extremely diverse material, and can be combined with other elements (including gases and metals) to produce different materials with various superior properties. Researchers all over the world continue to constantly investigate and patent graphene to learn its various properties and possible applications, which include:

- batteries
- transistors
- computer chips
- energy generation
- supercapacitors
- DNA sequencing
- water filters
- antennas
- touchscreens (for LCD or OLED displays)
- solar cells
- Spintronics-related products

Supercapacitor:

A **supercapacitor (SC)**, also called an **ultracapacitor**, is a high-capacity capacitor with a capacitance value much higher than other capacitors, but with lower voltage limits, that bridges the gap between electrolytic capacitors and rechargeable batteries. It typically stores 10 to 100 times more energy per unit volume or mass than electrolytic capacitors, can accept and deliver charge much faster than batteries, and tolerates many more charge and discharge cycles than rechargeable batteries.^[2]

Supercapacitors are used in applications requiring many rapid charge/discharge cycles, rather than long-term compact energy storage — in automobiles, buses, trains, cranes and elevators, where they are used for regenerative braking, short-term energy storage, or burst-mode power delivery.^[3] Smaller units are used as power backup for static random-access memory (SRAM).

Unlike ordinary capacitors, supercapacitors do not use the conventional solid dielectric, but rather, they

use electrostatic double-layer capacitance and electrochemical pseudocapacitance,^[4] both of which contribute to the total capacitance of the capacitor, with a few differences:

- **Electrostatic double-layer capacitors (EDLCs)** use carbon electrodes or derivatives with much higher electrostatic double-layer capacitance than electrochemical pseudocapacitance, achieving separation of charge in a Helmholtz double layer at the interface between the surface of a conductive electrode and an electrolyte. The separation of charge is of the order of a few ångströms (0.3–0.8 nm), much smaller than in a conventional capacitor.
- **Electrochemical pseudocapacitors** use metal oxide or conducting polymer electrodes with a high amount of electrochemical pseudocapacitance additional to the double-layer capacitance. Pseudocapacitance is achieved by Faradaic electron charge-transfer with redox reactions, intercalation or electrosorption.
- Hybrid capacitors, such as the lithium-ion capacitor, use electrodes with differing characteristics: one exhibiting mostly electrostatic capacitance and the other mostly electrochemical capacitance. The electrolyte forms an ionic conductive connection between the two electrodes which distinguishes them from conventional electrolytic capacitors where a dielectric layer always exists, and the so-called electrolyte, e.g., MnO₂ or conducting polymer, is in fact part of the second electrode (the cathode, or more correctly the positive electrode). Supercapacitors are polarized by design with asymmetric electrodes, or, for symmetric electrodes, by a potential applied during manufacturing.

Application of Supercapacitors:

Due to unique storage capability of supercapacitors, it has been widely used in various applications like electric drives, UPS, traction, electric vehicles, SSD's, LED flashlights etc. Let us discuss few of them.

Supercapacitors are used in the following:

1. Electric cars
2. Wind turbines
3. Photographic flash
4. Flywheel in machines
5. MP3 players
6. Regenerative braking in the automotive industry
7. Static memories (SRAM)
8. Industrial electrical motors

UNIT-III: Electrochemistry and applications

Lecture notes

Electrochemistry

“The branch of physical chemistry that deals with the inter-conversions of chemical energy and electrical energy is known as Electrochemistry.”

Conductors:-

A substance which allows electric current or heat to pass through is called conductor.eg:-

Metals, Aq. Solution of Salts, Acids & Bases.

Electric conductors are of two types.

i) **Metallic conductors:-** The substance which conducts electricity by transfer of electrons without dissociation of it. eg:- Metals, M_(S) -----→ M_(aq)ⁿ⁺ + n e⁻

ii) **Electrolytic conductor (Electrolytes):-** When an electric current is passed through a substance (electrolyte), it decomposes into ions. (Undergoes chemical changes)

eg:- Acids, Bases, Salts, etc.

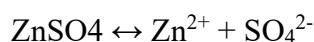

-Electrolyte is a substance which conducts electricity by chemical decomposition in solution or fused

state. ||

Theory of Electrolytic dissociation:-

Electrolytes when dissolved in solvent dissociates into ions of one positive and other negative charge.

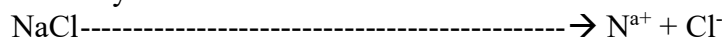

- ii) When electric current is passed through the electrolytic solution (electrolyte dissolved in solvent), the positive ions moves towards cathode called cations and negative ions moves towards anode called anions.

Degree of ionisation:- The ratio of dissociated ions to the un-dissociated molecules is called degree of ionisation.

$$\alpha = \frac{\text{No. of ions}}{\text{No. of un - dissociated molecules}}$$

- iii) The properties of ions depend on the properties of electrolytes.

Electrochemical cells:-

Electrochemical cell constitutes two electrodes and an electrolyte due to whichelectric current is produced as a result of chemical reactions and vice versa.

Electrochemical cell is used to i) convert chemical energy into electrical energy

ii) convert electrical energy into chemical energy

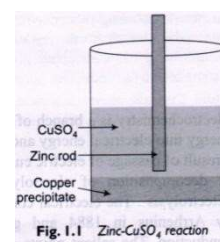

“Thus an electrochemical cell is a device in which redox reaction (oxidation and reduction) takes place which is utilised to get electrical energy.” This is also known as voltaic cell or galvanic cell.

Redox reaction: Simultaneous oxidation and reduction, this produces electricity and so called electrochemical changes.

Eg: Respiration in human, Photosynthesis in plants, combustion of petroleum, Leaching of Stains.

Oxidation: Addition of O₂ (or) Removal of H₂ (or) Removal of electrons.

Reduction: Removal of O₂ (or) Addition of H₂ (or) Addition of electrons.

To explain consider an electrode (Zn) dissolved in electrolytic solution (CuSO₄). The following reactionstake place.

Oxidation Half Reaction (OHR)

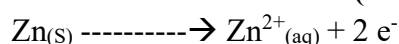

The overall reaction is as follows:

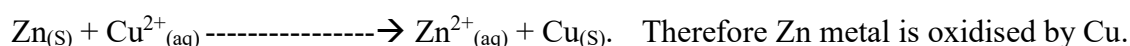

Reduction Half Reaction (RHR)

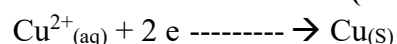

Electrode potential:-

The tendency of metal atoms to go into solution is called electrode potential.

eg:- M (metal) immersed in solution of its own ions (M^{n+}), the following changes takes place

- i) M^{n+} ions collide each other with M leads to no change.
- ii) M^{n+} ions collide with M and gains electrons.
- iii) M lose electrons and forms M^{n+} .

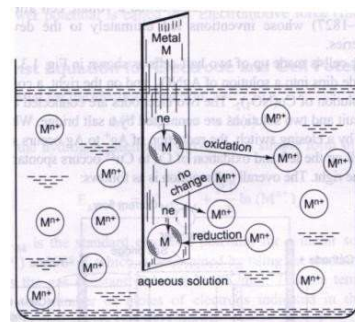

The electrode develops a small negative charge potential with respect to the solution.

Characteristics:

- i) If the tendency of M to oxidise into M^{n+} ions is high—no. of M^{n+} ions will be more.
- ii) If the tendency of M^{n+} ions to reduce into M is high—no. of M^{n+} ions will be less.

Note: Cu^{2+} reduces easily while $Zn(s)$ oxidises.

Galvanic cell:

It is made up of two half cells.

Ag(electrode)/ $AgNO_3$

||

Cu(electrode)/ $Cu(NO_3)_2$

These two electrodes are connected externally by circuit and internally by salt bridge through solution.

The redox reactions of Ag^+ to Ag and Cu to Cu^{2+} occur spontaneously in two half cells.

The overall cell reaction are as follows:

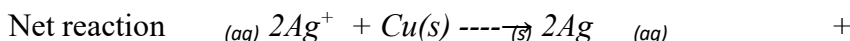
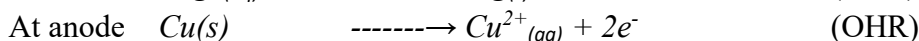
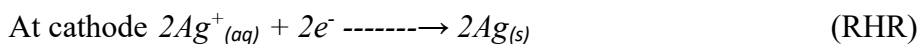

Cu^{2+}

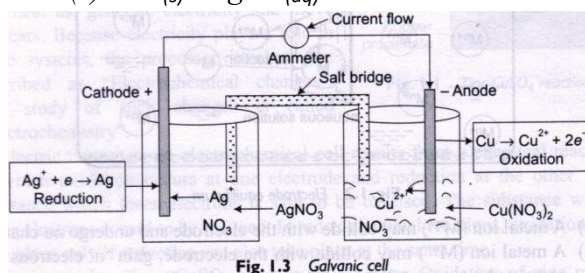

Fig. 1.3 Galvanic cell

Copper on oxidation gives e^- s, which travels through outer circuit (external) and transferred to Ag^+ ions – due to it is reduced to $Ag_{(s)}$. The no. of e^- s released from one electrode is equal to no. of e^- s abstracted by other ions (another half side).

Note: The e^- s flows from anode to cathode, but electricity flows from cathode to anode.

EMF (Electro Motive Force):-

It is defined as potential difference between two electrodes which allows the current flow from one electrode to another. The current flows from higher potential to lower potential.

Measurement of EMF:- (Poggendorf's compensation method)

Voltmeter is used for the EMF measurement and it can be measured by connecting two electrodes to the two terminals of voltmeter. This method is inaccurate due to two reasons.

- i) Some current drawn from the cell by voltmeter, which causes alteration of chemical equilibrium.
- ii) While current flows, part of EMF is used to overcome internal resistance.

So to measure EMF accurately without disturbing chemical equilibrium and to avoid internal resistance, Poggendorf's compensation method is widely used.

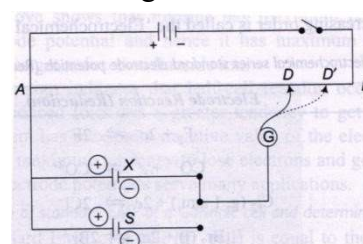

In this technique, the EMF to be measured is balanced by equal and opposite EMF from another cell or battery and there is no net flow current in the circuit.

- The total assembly is known as Potentiometer.
- It consists of a uniform wire 'AB' of high resistance and battery 'C' is attached to the side wire AB through a Rheostat 'R'.
- The cell 'X', whose EMF to be measured is included in another circuit by connecting to the end A of the wire through a press key (K₁), Galvanometer (G) and a jockey (sliding contact D).
- The first circuit is completed by introducing key (K₁).
- The jockey is slid along the wire till point D is reached and the galvanometer shows null deflection, the position D is noted.
- The second circuit is then completed through the standard cell (S) of known EMF by introducing key (K₂).
- The jockey is again moved along the wire 'AB' till the point 'E' is reached (when no deflection is observed) and it is noted.

Then $E_X \propto \text{length AD}$

$E_S \propto \text{length AE}$

AE

Or $E_X/E_S = \text{length AD} / \text{length AE}$

$E_X = \text{length AD} / \text{length AE} \times E_S$

Therefore AD, AE & E_S are known

Note: AB is calibrated.

Nernst equation: - Electrode potential (cell potential) Consider an electrode reaction,



The Nernst equation for the above reaction is given as follows:

$$E_M = E_M^{\circ} + \frac{RT}{nf} \ln [M^{n+}]$$

Where E_M = Electrode potential of given metal ion

E_M° = Standard electrode potential

potential

R = Gas constant, 8314 J/K/mol / 2Kcal/T =

Temperature

n = no. of moles of electrons f =

Faraday (f = 96500 C/mol)

Nernst equation for cell potential

Consider Daniel cell and the electrodes and ions are denoted as follows:

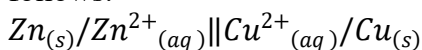

OHR

RHR

The electrode potential for RHR's written as

$$E_{Cu^{2+}/Cu} = E_{Cu^{2+}/Cu}^{\circ} + \frac{RT}{2f} \times \ln [Cu^{2+}_{(aq)}]$$

The electrode potential for OHR's written as

$$E_{Zn^{2+}/Zn} = E_{Zn^{2+}/Zn}^{\circ} + \frac{RT}{2f} \times \ln [Zn^{2+}_{(aq)}]$$

Total cell potential = RHR - OHR

$$E_{cell} = \{E_{Cu^{2+}/Cu}^{\circ} + \frac{RT}{2f} \times \ln [Cu^{2+}_{(aq)}]\} - \{E_{Zn^{2+}/Zn}^{\circ} + \frac{RT}{2f} \times \ln [Zn^{2+}_{(aq)}]\}$$

$$= (E_{Cu^{2+}/Cu}^{\circ} - E_{Zn^{2+}/Zn}^{\circ}) + \frac{RT}{2f} \times \ln [Cu^{2+}_{(aq)}] - \frac{RT}{2f} \times \ln [Zn^{2+}_{(aq)}]$$

$$= (E_{Cu^{2+}/Cu}^{\circ} - E_{Zn^{2+}/Zn}^{\circ}) + \frac{RT}{2f} \times \ln \frac{[Cu^{2+}_{(aq)}]}{[Zn^{2+}_{(aq)}]}$$

$$= E_{cell}^{\circ} + \frac{RT}{2f} \times \ln \frac{[Cu^{2+}_{(aq)}]}{[Zn^{2+}_{(aq)}]}$$

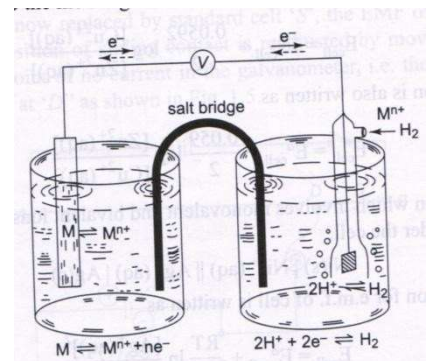

substituting the values of R, T and F we get

$$= E_{\text{cell}}^0 + 0.0592/2 \ln [\text{Cu}^{2+}_{(\text{aq})}] / [\text{Zn}^{2+}_{(\text{aq})}]$$

After converting natural logarithm into log, we get

$$= E^{\circ}_{\text{cell}} + 0.0592/2 \log [\text{Cu}^{2+}_{(\text{aq})}] / [\text{Zn}^{2+}_{(\text{aq})}]$$

$$= E^{\circ}_{\text{cell}} - 0.0592/2 \log [\text{Zn}^{2+}_{(\text{aq})}] / [\text{Cu}^{2+}_{(\text{aq})}]$$

eg: consider another following cell and whose cell reaction is written as follows



Cell potential is written as

$$E_{\text{cell}} = E^{\circ}_{\text{cell}} + 0.0592/2 \log [\text{Ag}^{2+}_{(\text{aq})}]^2 / [\text{Ni}^{2+}_{(\text{aq})}]$$

In general it is written as $aA + bB \rightarrow cC + dD$

$$E = \frac{2.303}{T} \log \frac{(C)^c (D)^d}{(A)^a (B)^b}$$

Standard Electrode

Potential:-

-The tendency of an electrode to loss or gain e^- s when it is in contact with its own solution (eg:- Zn/ZnSO₄) is called electrode potential. ||

-The tendency of an electrode to loss or gain e^- s when it is in contact with its own solution (eg:- Zn/ZnSO₄) in standard conditions i.e., 25° C, 1 atm. pressure and 1M conc. Of solute is called electrode potential or Standard Reduction Potential (SRP). ||

Daniel cell comprises of two half cells i.e., OHR and RHR. So, one gets oxidised and gets reduced.

The Standard Electrode Potential is obtained as follows:

$E^{\circ}_{\text{cell}} = [\text{Standard Reduction Potential (SRP)}] - [\text{Standard Reduction Potential (SRP)}]$ of the substance reduced of the substance oxidised

E°_{R} - Right

R

E°_{L} - Left

The Standard Electrode Potential of different electrodes is given in table. The values of Standard Reduction Potentials are arranged in decreasing order known as -Electrochemical series. ||

Eq.

The positive ion values of the electrodes are tendency to accept e^- s (reduced). The negative ion values of the electrodes are tendency to donate e^- s (oxidised).

Calculations:- EMF – Galvanic.

i) E°_{Cell} is given by $E^{\circ}_{\text{Cell}} =$

$$E^{\circ}_{\text{R}} - E^{\circ}_{\text{L}}$$

ii) Notation of cell.

For right electrode Ion/Electrode {eg:- Cu²⁺/Cu} For left

electrode Electrode / Ion {eg:- Zn/ Zn²⁺} i.e., Cu²⁺/Cu ||

Zn/ Zn²⁺ (|| is salt bridge)

Salt bridge:

iii) Complete cell reaction is the sum of two half cell

Prediction of feasibility of reaction

i) If the net EMF of the cell (i.e., from left and right) is positive (+), then the reaction is spontaneous i.e., reaction takes place.

eg:- Zn/ Zn²⁺; Cu²⁺/Cu

$$E^{\circ}_{\text{Cell}} = E^{\circ}_{\text{R}} - E^{\circ}_{\text{L}} \{E^{\circ}(\text{Cu}^{2+}/\text{Cu}) - E^{\circ}(\text{Zn}/\text{Zn}^{2+})\}$$

$$= 0.34 - (-0.76)$$

$$= 0.34 + 0.76$$

$$= +1.10\text{V}$$

ii) If the net EMF of the cell (i.e., from left and right) is negative (-), then the reaction is non-spontaneous i.e., reaction does not take place.

eg:- Fe²⁺/ Fe; Ni/Ni²⁺

$$E^{\circ}_{\text{Cell}} = E^{\circ}_{\text{R}} - E^{\circ}_{\text{L}} \{E^{\circ}(\text{Fe}^{2+}/\text{Fe}) - E^{\circ}(\text{Ni}/\text{Ni}^{2+})\}$$

$$= -0.44 - (-0.25) = -0.19 \text{ V}$$

So from the net EMF, we are able to say whether reaction is spontaneous or not. Thus oxidising agent (with higher reduction potential) will oxidise any reducing agent (with lower reduction potential). Similarly reducing agent will reduce any oxidising agent.

Proble

ms:-

Batterie

s:

A battery is one or more electrochemical cells in which stored chemical energy can be converted into electrical energy.

Types of electrochemical cells Galvanic, Electrolytic, Fuel Flow, Voltaic cells

etc. Battery depends on composition, current drain and temperature.

So battery is one which converts chemical energy to electrical energy i.e., e⁻ flows from donor (e⁻ rich) to acceptor (e⁻ deficient) through external circuit. This happens due to the difference in **voltage** called **cell voltage**.

Classification:-

Batteries are broadly classified into the following types

Primary batteries or cells:-

In these batteries the cell reactions are in directional i.e., chemical energy can be converted into electrical energy and cannot be reversed. These batteries once used have to be discarded or disposed.

Eg:: Dry cells, Hg cells, etc

Secondary batteries or cells:-

These are also called as storage cells or accumulators. In these batteries the cell reactions are reversible i.e., chemical energy can be converted into electrical energy and vice versa. When we pass electricity in opposite direction, it is stored in the form of chemical energy.

Eg:: Pb – H₂SO₄ storage cell (Lead

Acid) Ni – Cd storage cell (NICAD)

Lithium batteries

Hg batteries

Two more types of batteries are (i) Reverse batteries

(ii) Flow batteries or Fuel cells

Secondary batteries – some examples

a) **Lead accumulator or Lead acid storage cells:-** A storage cell acts as voltaic and electrolytic cell.

Voltaic cell – chemical to electrical – discharging

Electrolytic cell – electrical to chemical – charging Lead Acid storage cell consists of 3 – 6 cells joined in series. The electrodes are

Anode – Pb
Cathode – PbO₂

Electrolytic solution – H₂SO₄ – (H⁺ + SO₄²⁻ ions)

Discharging:- Here the chemical energy which is stored is converted into electrical energy.

The electrode reactions are

At Anode

Pb is dissolved into Pb²⁺ ions, which reacts with SO₄²⁻ ions to form PbSO₄ ppt.

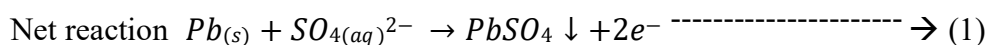
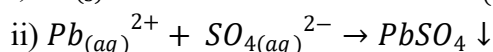
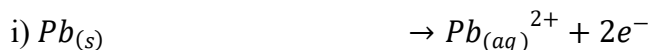

At cathode

PbO_2 is converted into Pb^{2+} ions which react with SO_4^{2-} ion to form PbSO_4 ppt.

Note:: PbO_2 (Pb^{4+}) reduced to (Pb^{2+}) PbSO_4

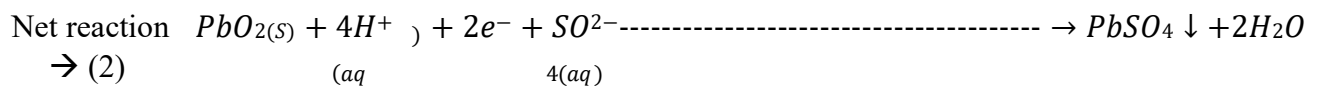
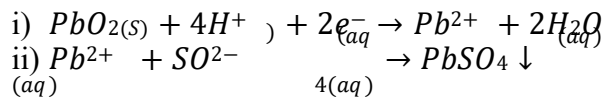

The net reaction of discharging process is given from eq. (1) & (2)

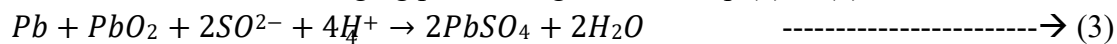

Recharging or charging:-

Cell stops working after the cell is dead. Now electrical energy is supplied which will be stored in the form of chemical energy. This is the reverse of the discharging process. This is done by applying high voltage.

The electrode reactions are:

At Anode:

The formed PbSO₄ precipitate reacts with e⁻ and forms dissociates into Pb_(s) and SO₄²⁻ ions.

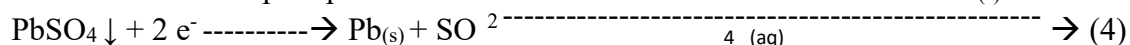

At Cathode:

PbSO₄ reacts with H₂O to form PbO₂ & SO₄²⁻ ions

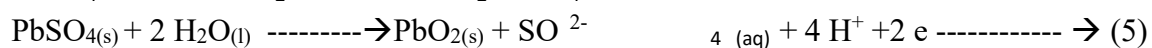

The net reaction of recharging process is given from eq. (4) & (5)

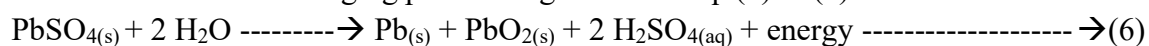

The overall net reaction of discharging and charging process is

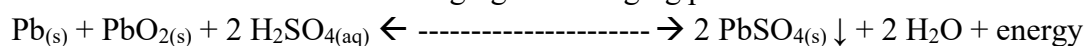

Applications:

- Pb-H₂SO₄ storage cells are used in current supply for electrical vehicles in railways, mines, telephone exchanges, labs, hospitals, automobiles etc., in automobiles 6 cell in series are used.

Fig.

b) **Nickel-Cadmium cell:** (Nicaid battery)

- This has high energy density due to which it is easily discharged and charged.
- It produces a volt of 1.4V.

The electrodes are

Anode – Cd

Cathode – NiO(OH) paste

Electrolytic solution – H₂O

Discharging: The electrode reactions are

At Anode:

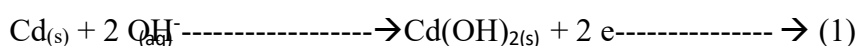

At

Cathode:

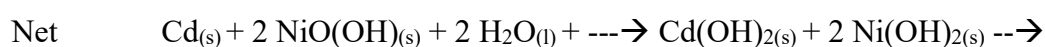
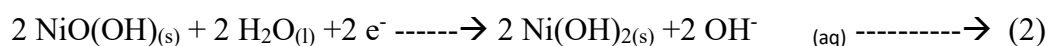

Cell reaction

Note: The formed products Ni(OH)₂ & Ni(OH)₂ are *adhered* to the electrode surfaces.

Charging:

While charging, the above electrode reactions are reversed. Since the products are adhered to the electrode surfaces.

Applications:

- Nicad batteries are used in portable power tools (flash units).
- It is also used in CD players, electronic cars, calculators, transistors etc.

c) **Lithium batteries:**

From the electrochemical series, it is observed that Li has most negative Standard Reduction potential (-3.05). Characteristics of Li:

- Lot of appeal of anode material
 - Light metal -corresponding lithium cells is also light weight. Lithium batteries are of two types:

i) **Primary batteries:-**

It is one of the most common Lithium primary cell, it is known as battery.

Li-MnO₂

The electrodes are

Anode – Li

Cathode – Heat treated MnO₂

Electrolytic solution – Propylene carbonate, dimethoxy ethane in LiClO₄

The electrode reactions are

At Anode:

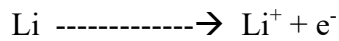

At

Cathode:

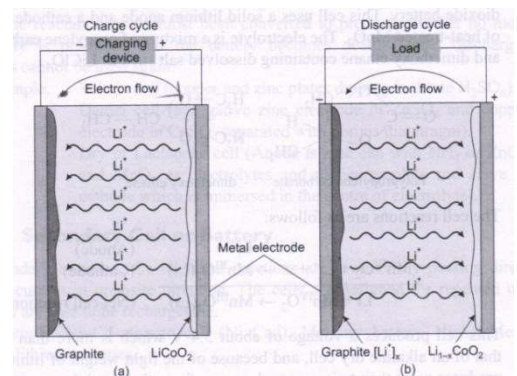
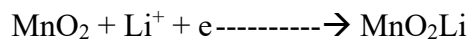

Net cell reaction $\text{Li} + \text{MnO}_2 \rightarrow \text{MnO}_2\text{Li}$

[Mn (IV) reduced to Mn (III)]

Applications:

- Produces a voltage of about 3.4V (double the alkaline dry cell).
- It is used in things require high current drains or photo flash.

ii) **Rechargeable batteries:**

- These cells contain Li^+ ions instead of metallic Li.
- Instead of oxidation and reduction, Li^+ ions are transported from one electrode to other through electrolytic solution.
- This is compensated by transport of e^- s in the external circuit.
- Li^+ ions are able to slip between the two layers of atoms in certain crystals such as graphite (C_6) and LiCoO_2 .

Charging:

- When the cell is constructed, it is uncharged state with no Li^+ ions between the layers.
- An external voltage forces e^- s through external circuit and causes Li^+ ions to travel from the LiCoO_2 electrode to C_6 (graphite) electrode (but e^- s moves from C_6 (graphite) electrode to LiCoO_2 electrode).
Say for eg. x Li^+ ions are transported from LiCoO_2 electrode to C_6 (graphite) electrode.

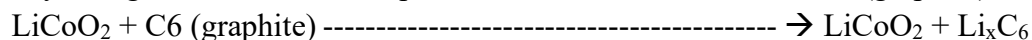

Discharging:

- When the cell is fully charged, it is ready to discharge continuously to give electrical power.
- During discharging Li^+ ions move back through the electrolyte from C_6 (graphite) electrode to LiCoO_2 electrode (but e^- s moves from LiCoO_2 electrode to C_6 (graphite) electrode).

Say for eg. y Li^+ ions are transferred from C_6 (graphite) electrode to LiCoO_2 electrode.

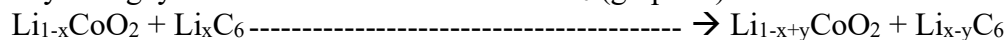

Thus charging and discharging cycle consists of movement of Li^+ ions from LiCoO_2 to C_6 and e^- flows in reverse to maintain balance in the external circuit.

Zinc Air battery:

1. Zinc-air batteries can be used to replace now discontinued 1.35 V mercury batteries (although with a significantly shorter operating life), which in the 1970s through 1980s were commonly used in photo cameras.
2. During discharge, a mass of zinc particles forms a porous anode, which is saturated with an electrolyte. Oxygen from the air reacts at the cathode and forms hydroxyl ions which migrate into the zinc paste and form zincate, releasing electrons to travel to the cathode. The zincate decays into zinc oxide and water returns to the electrolyte. The water and hydroxyl from the anode are recycled at the cathode, so the water is not consumed. The reactions produce a theoretical 1.65 volts, but this is reduced to 1.35-1.4 V in available cells.

3. **The chemical equations for the zinc-air cell are:**

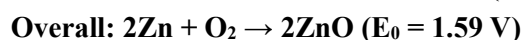
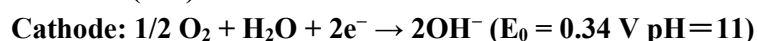
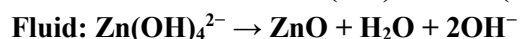

Zinc-air batteries cannot be used in a sealed battery holder since some air must come in; the oxygen in 1 liter of air is required for every ampere-hour of capacity used.

Applications:

- Their applications vary from very small button cells for hearing aids, larger batteries used in film cameras that previously used mercury batteries, to very large batteries used for electric vehicle propulsion.

Fuel Cells:-

In comparison with galvanic cell, which produces electrical energy for limited period due to depletion of reactants – fuel cells are electrochemical cells which produce energy as long as reactants are supplied. This makes fuel cells an attractive source of power.

Chemical energy -----> Electricity (No combustion of gas & O₂)

Fuel + O₂ -----> Oxidation product + Electricity

Two of fuel cells are discussed below:

i) H₂-O₂ Fuel cell:-

- Simplest and successful
- Consists of electrolyte (Con. Soln. of KOH) in the centre compartment, which is in contact with two electrodes that contain Pt catalyst to facilitate reactions.
- H₂ & O₂ under pressure circulated, so as to come in contact with electrodes

The electrode reactions are:

At cathode 2 H_{2(g)} + 4 OH⁻ -----> 4 H₂O_(l) + 4 e⁻ (RHR)

At anode O_{2(g)} + 2 H₂O_(l) + 4 e⁻ -----> 4 OH⁻_(aq) (OHR)

Net reaction 2 H_{2(g)} + O_{2(g)} -----> 2 H₂O_(l)

EMF, E^o = 1.23 V.

But in practice the EMF, E^o = 0.8 to 1.0 V. Generally large numbers are connected in series to make battery.

Advantages:-

- Attractive alternate to gasoline powered engines
- Pollution free & only by-product is H₂O.
- Thermodynamically efficient – (efficiency) (gasoline & diesel engines – 25-30% efficiency.)

Disadvantages:-

- Energy cost of H₂ fuel generation is high.
- Problem in storage & distribution of H₂ (highly inflammable).
- Availability of alternate fuels.

Applications:-

- H₂-O₂ fuel cells are used as auxiliary energy source in space vehicles, submarines or military vehicles.
- As the by-product is H₂O, used as fresh water for astronauts.
- For 15 days, weight required is 250 kg.

ii) CH₃OH-O₂ fuel cell:-

- CH₃OH-O₂ is an important fuel cell.
- Oxidation of CH₃OH, takes place on catalyst (Pt) to form CO₂.
- Water consumed at anode and produced at cathode.
- H⁺ are transferred across the proton exchange membrane.
- H⁺ reacts with O₂ to form H₂O.
- e⁻ s are transported through an external circuit from anode to cathode.
- CH₃OH & H₂O are absorbed on catalyst (Pt) to form CO₂ with loss of H⁺.

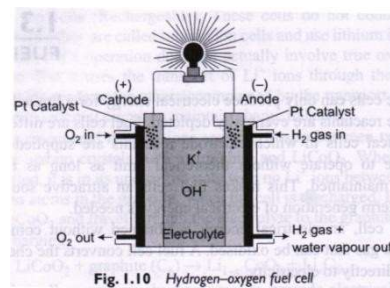

Fig. 1.10 Hydrogen-oxygen fuel cell

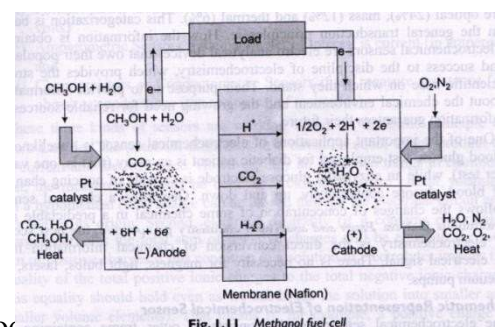
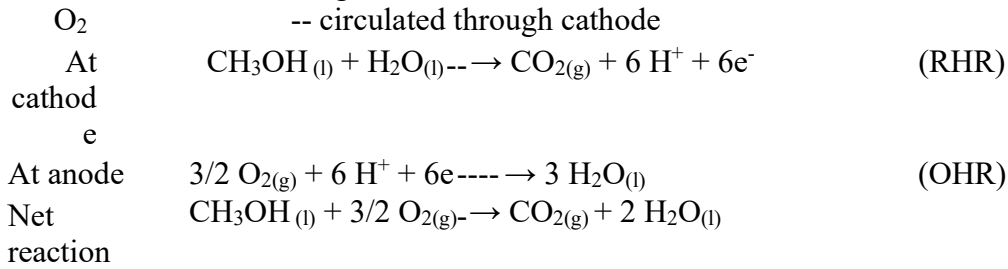

Fig. 1.11 Methanol fuel cell

CH₃OH & H₂O – circulated through anode



From the above cell reactions it is observed that...

- CO₂ is formed by the addition of H₂O.
- 6 H⁺ reacts with 6 e⁻ s.
- One mole of CH₃OH reduces 3/2 O₂ to 3 H₂O (part of this is introduced at fuel compartment again).
- For 6 e⁻ transfer, standard cell voltage 1.21V is maintained.
- Energy density produced is 6 KWH / kg methanol.

Advantages:-

- Storage is easier, no high pressure or low temperature is required (-97.0° C to 64.7° C exists as liquid).
- The energy density of the cell is comparatively higher than H₂-O₂ cell.

Electrochemical sensors:

-Sensor is a device, which provides information regarding sample continuously in the form of analytical assay and gives information in the discrete steps.||

There are different types of sensors:

- i) Electrochemical sensors 58%
- ii) Optical sensors 24%
- iii) Mass sensors 12%
- iv) Thermal.....06%

- Electrochemical sensors are the largest group of sensors.
- In the Electrochemical sensors, the electro analytical devices which provide strong scientific base, chemical environment and growing need for reliable sources of information guarantees their future.
- The important application of electrochemical sensor is assay of blood glucose.
- Enzymatic glucose electrode is capable sensing the blood glucose level continuously. (Concentration changes continuously).
- It is clear that electrochemistry scope is to convert chemical information into electrical signal. No need of magnets (MRI, CT scans), light bulbs (endoscopy), vacuum pumps, etc.

Electrochemical sensors- Schematic representation.

- It consists of outer frame with electrolytic gel and three electrodes.
- It has permeable membrane the top.
- The electrodes should have: -Large surface area
-long life
-highly sensitive

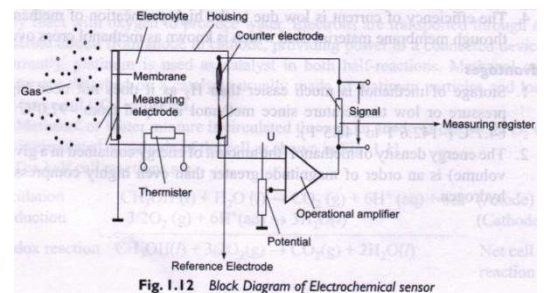

Fig. 1.12 Block Diagram of Electrochemical sensor

- Each cell consists of special filter electrodes & electrolytes with high specificity.
 - Even small amount of electrolyte is enough for large signal and gives immediate response.

Fig.

Classification of Electrochemical sensors:

Based on electrical parameter, these are divided into three

types. They are:

- i) Potentiometric sensors – Parameter – potential (V)
- ii) Amperometric/Voltametric sensors – Parameter – current (A)
- iii) Conductometric sensors or Chemiresistors – Parameter – Resistance (R) or (C)

- These three above sensors works based on ‘Ohms law’ principle.
- The pd (potential difference) in a circuit is equal to product of current & resistance

$$V = i \times R$$
- For all the three sensors, measurement is done with closed electrical circuit i.e., test charge can be passed through the electrical circuit and return to its origin.
- All the three sensors maintains electrical neutrality i.e., sum of positive charges are equal to sum of negative charges (this electrical neutrality is maintained as we divide solutions into smaller & smaller even).
- The chemical specificity (recognition) comes from the Ion Selective Electrodes (ISE’s) and that is connected to amplifier.

Potentiometric sensors:

- Ion Selective Electrodes (ISE’s) are used in Potentiometric sensors.
- ISE’s depends on the concentration of ionic species in the test solution used for electro analysis.
- In ISE’s, the recognition of H^+ ions is done by glass electrode sensing element. This is coupled with reference electrode.
- Now sensor results come from the pd between these two electrodes.
- Glass electrode is the mother of all ISE’s, which is highly sensitive (selective) to H^+ ions and requires high input impedance.
- Glass electrode has high resistance, due to glass membrane and it is the oldest of all electrochemical sensors.

- Glass electrode was introduced by Arnold

Beckmann. Working Principle:

- The working principle is similar to glass electrode & common to all ISE’s.
- The glass electrode is represented as follows
Ag, AgCl / 1M HCl / H^+ (test solution)
- Potential of glass electrode depends on the conc. of H^+ ions.
- As a result of difference in conc. Of H^+ ions on two sides of membrane potential difference is developed.

Ion Selective Electrode (ISE):

- ISE has a membrane which is sensitive to a particular chemical species.
- ISE respond to certain specific ions present in a mixture while ignoring others and develop potential.
- The potential developed is a measure of concentration of species of interest
- Glass electrode on its surface develops a thin gel like layer of H^+ ions (hydrated). So, partition is developed.

The Nernst eq. is given by

The potential = standard electrode potential + correction term for the deviation from the unit concentration of the reactant and product of the electrode.

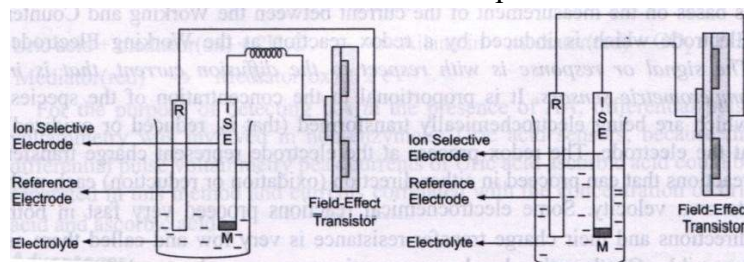

Basic requirements of potentiometric sensors:

- ✓ It requires a stable & reproducible reference.
- ✓ Electrode has a well known & stable equilibrium electrode potential.
- ✓ It is used as reference point against which the potential of other electrodes can be measured. But few commonly used electrodes have potential independent of electrolyte used.
Eg: Ag-Cl electrode, calomel electrode (0.244v). / H₂ electrode (0.0v).
- ✓ Exactly 50% of the information from the measurement comes from the reference electrode.

Glucose Potentiometric sensors—(Estimation of glucose)

- Glucose is an electrically neutral molecule. C₆H₁₂O₆ cannot be divided into ions.
- So, without ions signals are not obtained.
- Hence glucose has to be converted into ions, which are selectively detected.

Oxidation of glucose

: Glucose is oxidised to gluconic acid with liberation of H⁺ ions & e⁻s. D-Glucose + O₂ + H₂O -----→ D-Gluconic acid + H₂O (2H⁺ + O₂ + 2e⁻)

- When Glucose Dehydrogenase (GDH) is used, the reactions are
D-Glucose + GDH_(Oxidised) -----→ δ-Glucolactone + GDH_(Reduced)

Note: Glucose content in blood and urine sample are different. Because after the threshold level only in blood, then goes into the urine.

Amperometric sensors: (Voltametric sensors)

Principle : This is a second kind in which it works based on the measurement of current between the working & counter electrode, which is initiated by Redox reaction at working electrode.

- The signal or response depends on the diffusion of current.
- But, the Diffusion of current \propto Conc. of species at the electrodes.
- The redox process at the electrode represent charge transfer reactions that can proceed in either direction (oxidation and reduction) with its own rate of reaction.
- Electrochemical reactions are of following types:

1. **Reversible:**

- Very fast in both directions
- Charge transfer resistance is low
- Charge transfer capacity is high

2. **Irreversible:**

- Very slow in rate of reaction
- Charge transfer resistance is high
- Charge transfer capacity is low
- Rate of electrode reactions depends on applied potential.
- At high negative potential: reduction is faster & charge transfer resistance is low.
- At high positive potential: oxidation is faster & charge transfer resistance is low.
- Micro electrodes give best measurements, which are smaller than 20 μ m, because size of electrodes plays a key role in amperometric sensors.

➤ Principle of operation: Glucose sensitive electrode (biocatalyst-glucose electrode).

Uses of Amperometric sensors:

- ✓ Oxygen sensors (or) Clark electrode is used in estimation of DO in water
- ✓ These are used in gas analysis in food & beverage industry.
- ✓ Used in detection of hazardous materials like explosive gases.

Estimation of Uric Acid (UA):

- Uric acid is a major nitrogenous compound in urine.

- During the metabolism, purines are converted into uric acid in urine.
- Biological determination of uric acid comes from the electrochemical interference such as Ascorbic acid (AA), which has similar oxidation potential. This creates major problem in the determination of UA.
- UA is present at high conc. in biological system.
- Estimation of UA is done by two methods.

1. **Enzymatic Method:** (two Process)

A) Uric acid is converted into Allatonin with the release of CO₂ by uricase enzyme. Uric acid + O₂ + H₂O -----> Allatonin + H₂O₂ + CO₂

B) Uric acid is converted into Allatonin by e- transfer mediators.

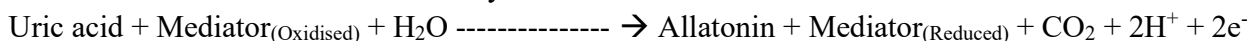

2. **Non-enzymatic method:**

Differential pulse voltammeter is used to detect uric acid in the presence of AA. Peak currents of UA & AA could be separated in this method and current correlated with conc. of both.

Advantages of Electrochemical sensors:

- ✓ When the analyte is optically inactive, in such condition electrochemical sensors are used.
- ✓ Electrochemical sensors are used in the analysis of more inorganic ions.
- ✓ Electrochemically inactive ions are also determined with the help of polymer modified electrodes.
- ✓ Oxygen and toxic gases like (N₂O_y), (S_xO_y), (C_xO_y) & H₂S.
- ✓ Environmental pollutants are monitored.
- ✓ To estimate the conc. of ions in blood, urine and other biological samples
- ✓ To check the conc. levels of fertilizers, pesticides, drugs and pharmaceuticals, etc.

UNIT-IV: Polymers Chemistry

Lecture notes

INTRODUCTION:

- Matter is composed of many small units called molecules, which are in different sizes and shapes and associated with atoms. Polymers are giants or macro molecules which play a vital role in our daily life and provide the basic needs of our life (food, clothing and shelter).
- The word polymer was derived from Greek word 'poly' = 'many' and 'mers' = 'parts /units'.

Polymer: It is defined as a high molecular weight compound (macro molecule) made by linking together a large number of small molecules called **monomers**.

Ex: PVC, Polyethylene, Starch, Poly styrene, Proteins, DNA etc

Monomer: The basic repeating units present in a polymer are called monomer.

Ex: Vinyl chloride is a monomer of PVC.

Ethylene is a monomer of poly ethylene.

Glucose is a monomer of starch.

Styrene is a monomer of polystyrene.

Amino acids are the monomers of proteins.

Nucleotides are the monomers of Nucleic acids.

2) **Nomenclature:** polymers are given names based on two properties

1. Type of monomers present
2. Type of atoms present in back bone chain

(i) Type of monomers:

a) Homo polymer: If a polymer consists of identical monomers, then that polymers are called homo polymers. They may be linear, branched (or) Cross – linked.

Ex: PVC, Polythene, Teflon etc.....

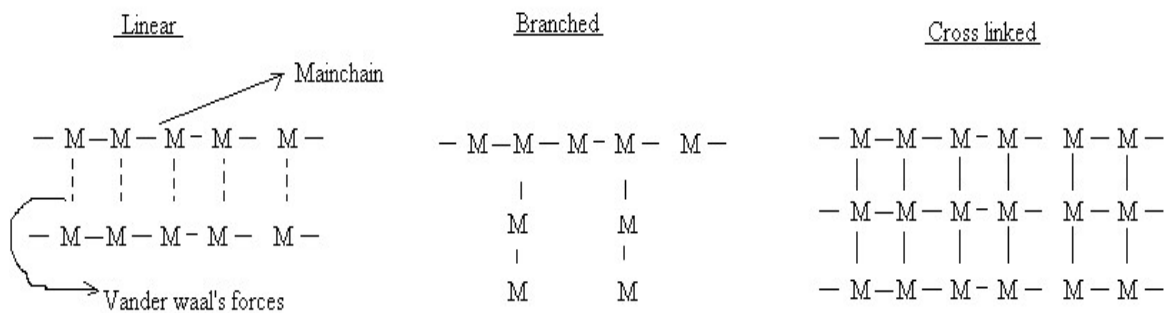

b) Hetero or Co-polymers: If a polymer is composed of different types of monomers, then it is called Hetero / co – polymers. They may be generally **linear (or) Branched**.

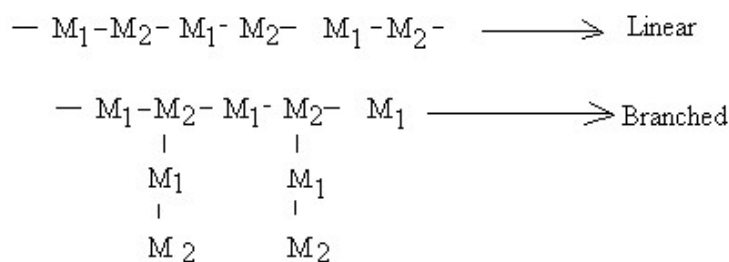

(ii) Type of atoms present in back bone chain:

a) Homo chain polymer: If the main chain is made up of same species of atoms is called homo chain polymer.



b) Hetero chain polymer: If main chain is composed of different atoms is said to be Hetero chain polymer

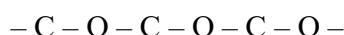

e) Graft co-polymers: These polymers are branched structures in which the monomer units on the branches and back bone differ.

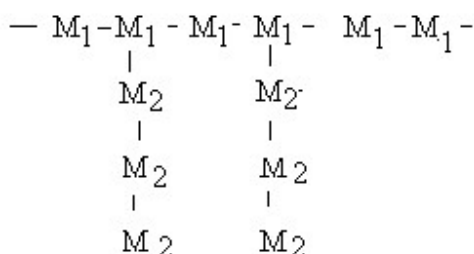

3) Tacticity: The orientation of functional groups in polymer is called as configuration. The difference in configuration of polymers because of the difference in arrangement of functional groups around main chain is called as Tacticity. Based on tacticity, polymers are of three types.

a) Isotactic: If all the functional groups are arranged on the same side of the chain, the polymer is called Isotactic polymer.

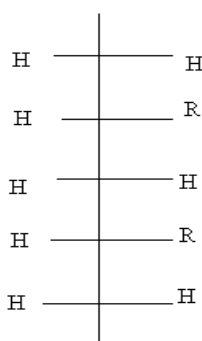

b) Atactic: If all the functional are arranged randomly around the main chain, the polymer is called Atactic polymer.

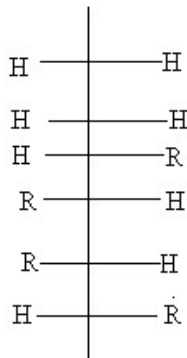

c) Syndiotactic: If all the functional groups are arranged alternately with respect to the main chain, the polymer is called syndiotactic polymer.

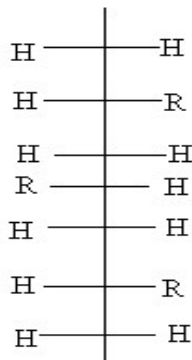

Polymerization:

1) Addition Polymerization:

- This polymerization takes place between monomers that are bifunctional and contains double bonds in its structure.
- This can be defined as binding of several bifunctional monomers to form polymers without elimination of by products by addition reactions.
- This polymerization results in the formation of linear polymers.
- The produced polymer has same chemical composition as that of monomers.
- The molecular weight of polymer is an integral multiple of the monomer.

Examples:

1. Formation of PVC:

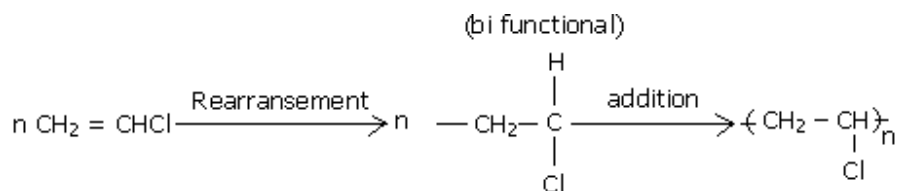

2. Polymerization of ethylene:

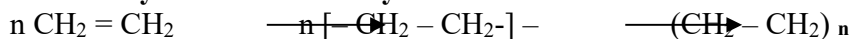

Plastics:

- An organic substance with high molecular weight, which can be moulded in to any desired form when subjected to heat (or) pressure in the presence of catalyst is called as plastic.
- The term plastic must be differentiated from resins.
- Resins are basic binding materials, which form a major part of the plastic and which actually undergo polymerization and condensation reactions during their preparations
- However, the term resin and plastic are considered as synonyms.

Advantages:

Now a days, plastics play an important role in daily life because of their certain unique properties.

- Light in weight
- Transparent
- Low maintenance cost
- Chemically inert
- Corrosion resistance
- Insect resistance
- Easy transportability
- Easy workability
- Impermeable to water
- High resistance to abrasion

Disadvantages:

- Low heat resistance, so combustible
- High softness
- Poor ductility
- Major pollutant not degraded by soil

Uses:

- For Making many house hold articles
- For making furniture
- For making electric goods

Types of Plastics: Plastics are classified in to two types

- Thermo plastics
- Thermo setting plastics.

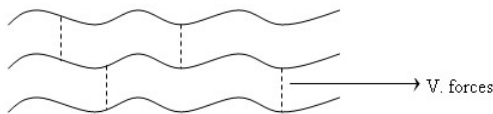
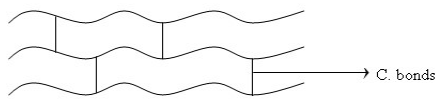
THERMOPLASTICS	THERMO SETTING PLASTICS
<ul style="list-style-type: none"> • They are formed by addition reactions. (some times formed by condensation r/n) • They become softened on heating & hardened on cooling • They are soft, weak and less – brittle. • Adjacent polymer chains are held together by weak Vanderwaal’s forces  <ul style="list-style-type: none"> • They have either linear (or) branched structures • The chemical nature is not altered during heating & cooling. • They can be remoulded, reshaped & reused so they can be reclaimed from waste. • Low molecular weight thermoplastics are soluble in suitable organic solvents <p>Ex: PE, PVS, PS, Nylon Teflon etc...</p>	<ul style="list-style-type: none"> • Formed by condensation reactions. • They become soft on initial heating and hard on cooling. On reheating they become more hard. • They are hard, strong and more – brittle. • Adjacent polymer chains are held together by strong covalent bonds.  <ul style="list-style-type: none"> • Due to strong bonds, they exhibit cross-linked 3D-structure. • Chemical changes takes place during moulding process. • They cannot be remoulded and reused so they cannot be reclaimed from the waste. • Due to strong bonds and cross links, they are not soluble in almost all organic solvents. <p>Ex: Bakelite, amino resins, poly ester resins, poly orethones epoxy resins etc.....</p>

Important plastics: Polythene, PVC, Polystyrene, Teflon, Nylon, Bakelite

1. Poly Vinyl Chloride (PVC):

Preparation: Vinyl chloride is used as monomer for the manufacture of polyvinyl chloride. Vinyl chloride is prepared by reacting acetylene with hydrogen chloride at 100-150⁰C in the presence of metal salt catalyst.

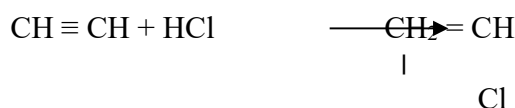

PVC is prepared by heating a water- emulsion of vinyl chloride in presence of Benzoyl Peroxide in a autoclave under pressure.

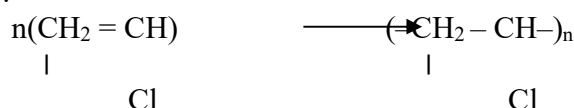

Properties:

- PVC is colorless and odorless Powder.
- It is non-inflammable and chemically inert.
- It is soluble in chlorinated hydrocarbons like ethyl chloride, etc. and ketones.

- It has high resistance to light, inorganic acids, alkalis, and atmospheric oxygen.

Uses:

- Plasticized PVC is used for making table cloths, rain coats, coatings for electric wire and cables, toilet articles, radio, T.V components, pipes, coupling valves, etc.
- Un-plasticized PVC or rigid PVC is used for making refrigerator components, cycle and motor cycle mudguards, tubes, pipes, etc.

BAKELITE: (Phenol formaldehyde resin / phenolic resin / phenoplasts)

- Bakelite is a important thermosetting resin named after the scientist Bakeland, who synthesized this resin in they year 1909.
- It is prepared by the step polymerization of phenol with formaldehyde in presence of an acid (or) Alkali as a catalyst.
- This polymerization takes place in three steps:

Step I: Phenol can condense with formaldehyde to produce O – hydroxy methyl phenol and P – hydroxy methyl phenol

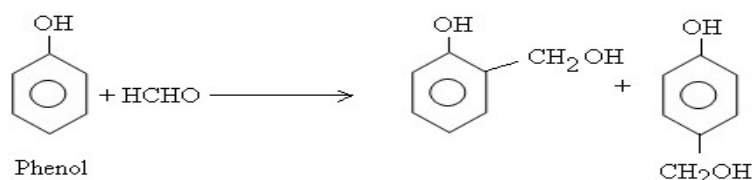

Step II: condensation takes place between O – hydroxy methyl phenol and phenol to give linear polymer called Novalac

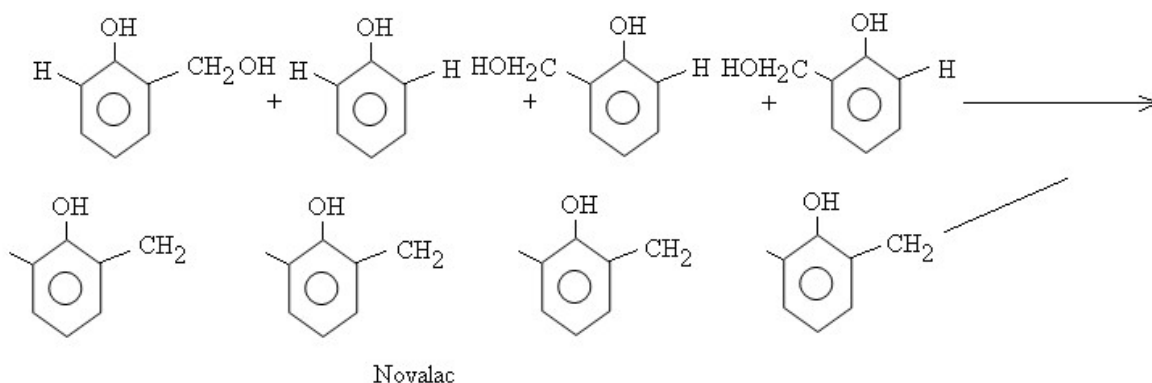

Step III: During molding, Hexa methylene tetraamine ((CH₂)₆ N₄) is added, it produces formaldehyde and ammonia. Formaldehyde converts the soluble and fusible Novalac in to a hard infusible and insoluble solid of cross – linked structure called Bakelite, whereas NH₃ neutralizes the acid.

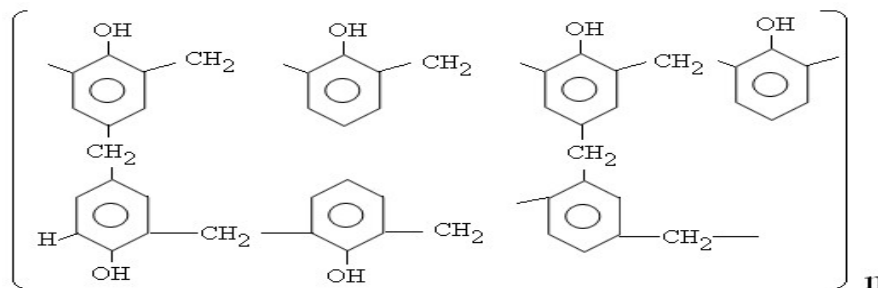

Properties:

- * Bakelites are rigid, hard, scratch resistant, infusible, water resistant, solid substance.
- * Resistant to acids, salts and most organic solvents but attacked by alkali due to the presence of hydroxyl groups.
- * Good electrical insulator

Applications:

- * For making electric insulator parts like switches, plugs, holders, switch boards, heater etc.....
- * For making moulded article like telephone parts, cabinets for radio and T.V.
- * Used in paints and varnishes
- * as adhesives for grinding and wheels.
- * In the product of ion exchange resin
- * For making bearings used in propeller shops, for paper industry and Rolling mills.

RUBBER (ELASTOMERS):

- The polymers which possess the property of elasticity are called as rubber.
- Rubbers are high polymers, which have elastic properties in excess of 300%.
- The molecular weight of raw rubber is about 1,00,000 to 1,50,000 Daltons.
- Most of the Indian production comes from kerala state.

Natural rubber: It is a high polymer of polyisoprene, which are arranged in Cis – Configuration (functional groups are arranged on the same side).

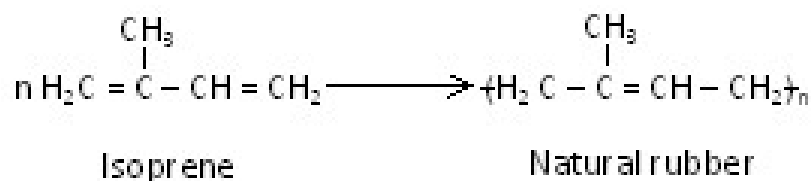

Natural rubber is mainly produced from the milk of the rubber tree “*Havea brasiliensis*”. Small quantities of natural rubber is also produced from the milk of a shrub known as “guayule”.

Processing of natural rubber:

- The milk of rubber tree is called latex.
- It is a colloidal emulsion consists a 25 – 45% of rubber and the reminder are protein and resinous materials
- The Latex was collected by cutting the bark of rubber trees.
- There after the Latex is diluted with water and filtered to eliminate dirt present in it. The Latex then coagulates by the addition of acetic acid (or) formic acid.
- The coagulated rubber is called as crude rubber. It is then made (or) rolled out in to sheets.
- The rubber sheets are dried under sunlight or mild heat and then subjected to further processing of rubber.

a) Crepe rubber: To the crude rubber, a small amount of sodium bi-sulphite is added to bleach the colour and passed into rollers which produce one mm or more thickness sheets which are dried in air about 40 to 50°C. The dried thin sheet of rubber are known as crepe rubber.

b) Smoked rubber: The crepe rubber sheets are placed inside smoke rooms maintaining a temperature 40 to 50°C for 4 days. The dried rubber sheets are called smoked rubber, which are sent to rubber factories for further processing.

Milk of rubber latex

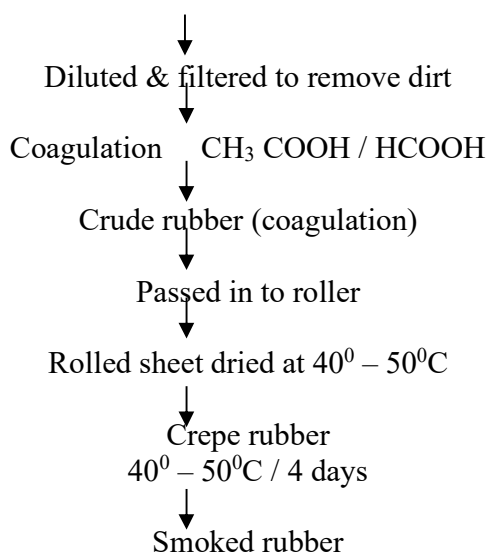

Draw backs of crude rubber (or) raw rubber: Crude rubber has following drawbacks.

1. Soft at high temperature and brittle at low temp.
2. It shows large water capacity
3. Shows little durability
4. Shows high elasticity
5. Attacks easily by oxidizing agents
6. Swells in organic solvents
7. Possess tackiness
8. Show low tensile strength.

The draw backs can be crude are rectified by the process of vulcanization.

Vulcanization:

- This was discovered by “Charles Good year” in 1839.
- The process of addition of sulphur at 110-140⁰C to natural rubber to improve its properties is called as “Vulcanization”.
- The added sulphur combines at the double bonds of rubber chains and cross – links of the linear polymer chains, resulting in a three dimensional network structure.
- Thus the rubber loses plastic state and acquires elastic state.
- The stiffness of vulcanized rubber depends on the amount of the sulphur added.
- A flexible tyre rubber contains about 3 – 5% if sulphur whereas hard rubber contains 32% of sulphur.

Applications / Uses:

1. It is mainly used for manufacture of tyres.
2. It is also used for floor tiles, shoe soles, gaskets, wire and cable insulations, Tank linings etc.....

2. Buna – N / Nitrile rubber: / GR – A rubber:

It is formed by copolymerization of 1, 3 but a – diene an Acrylo Nitrile.

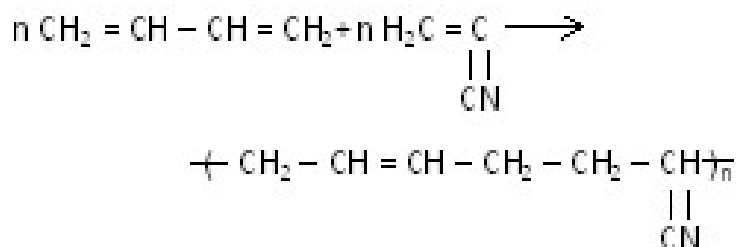

Properties:

- It can be vulcanized in same way as natural rubber.
- It has good oil resistance, heat resistance and abrasion resistance
- It is attacked by alkalis, due to presence of cynogroups.

Uses: making air craft components, conveyor belts, tank linings, gaskets, hoses, printing rollers, automobile parts etc.

3. Silicone rubber:

Preparation: It is formed by the polymerization of dihydroxy dimethyl silicon, which is formed by dichlorodi methyl silicon. This step requires water molecules and HCL elimination takes place.

Dihydroxy dimethyl silicon forms an unstable silicon rubber by dehydration which yields silicon rubber in the presence of peroxide and in organic fillers like TiO_2 , SiO_2 etc. by the polymerization.

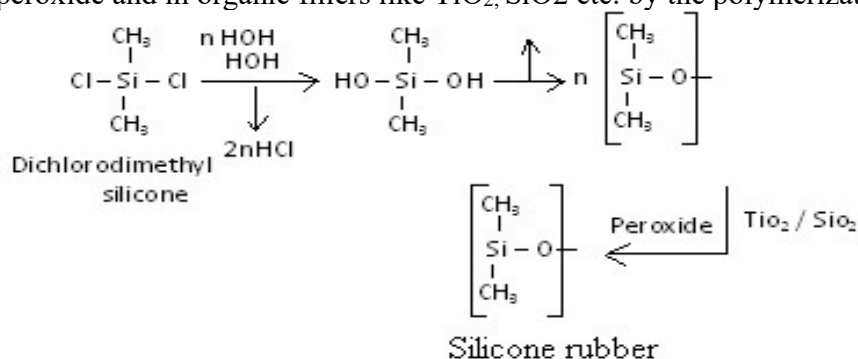

Properties:

- It has good resistant to Oils, dilute acids, alkalis and sunlight.
- It retains rubber properties at elevated temperatures.
- It is also resistant to air and ozone at high temperature.

Uses:

- It is mainly used in making lubricants, paints etc
- For making artificial heart valves, transfusion tubings, for special boots to be used at low temperature.

Nylon (Polyamide):-

The aliphatic amides are known as 'NYLON' which are synthetic fibre forming materials. These components contain -CO-NH- linkage. They are usually obtained from condensation of dibasic acids and diamines. Commercially Nylon-6,6 , Nylon-6 , Nylon- 11 are important.

(a) Nylon-6,6

Preparation
hexamethylenediamine.

It is obtained by the polymerization of adipic acid with

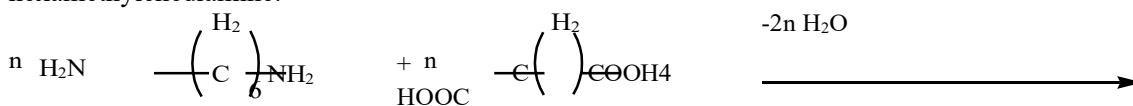

Hexamethylene diamine

Adipic Acid

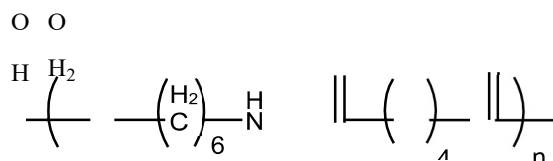

Properties:-

1. They are translucent, whitish, horny, high melting points (160–264⁰C) polymers.
2. They possess high temperature stability and good abrasion–resistance.
3. They are insoluble in common organic solvents like methylated spirit, benzene and acetone.
4. They are soluble in phenol and formic acid.

Uses:-

1. Nylon–6,6 is primarily used for fibres in making socks under–garments, dress, carpets, etc.
2. They are also used for making filaments for ropes, bristles for tooth–brushes and films, tyre –cords etc.,.
3. Nylon bearings and gears work quietly without any lubrication.

Carbon Fibers:

Carbon fibers or carbon fibres are fibers about 5–10 micrometres in diameter and composed mostly of carbon atoms. Carbon fibers have several advantages including high stiffness, high tensile strength, low weight, high chemical resistance, high temperature tolerance and low thermal expansion. These properties have made carbon fiber very popular in aerospace, civil engineering, military, and motorsports, along with other competition sports. However, they are relatively expensive when compared with similar fibers, such as glass fibers or plastic fibers.

Classification and types

Based on modulus, strength, and final heat treatment temperature, carbon fibers can be classified into the following categories:

Based on carbon fiber properties, carbon fibers can be grouped into:

- Ultra-high-modulus, type UHM (modulus >450Gpa)
- High-modulus, type HM (modulus between 350-450Gpa)
- Intermediate-modulus, type IM (modulus between 200-350Gpa)
- Low modulus and high-tensile, type HT (modulus < 100Gpa, tensile strength > 3.0Gpa)
- Super high-tensile, type SHT (tensile strength > 4.5Gpa)

Based on precursor fiber materials, carbon fibers are classified into:

- PAN-based carbon fibers
- Pitch-based carbon fibers
- Mesophase pitch-based carbon fibers
- Isotropic pitch-based carbon fibers
- Rayon-based carbon fibers

- Gas-phase-grown carbon fibers

Based on final heat treatment temperature, carbon fibers are classified into:

- Type-I, high-heat-treatment carbon fibers (HTT), where final heat treatment temperature should be above 2000°C and can be associated with high-modulus type fiber.
- Type-II, intermediate-heat-treatment carbon fibers (IHT), where final heat treatment temperature should be around or above 1500°C and can be associated with high-strength type fiber.
- Type-III, low-heat-treatment carbon fibers, where final heat treatment temperatures not greater than 1000°C. These are low modulus and low strength materials.

Manufacturing Process

Carbon fibers from polyacrylonitrile (PAN):

Raw Materials

The raw material used to make carbon fiber is called the precursor. About 90% of the carbon fibers produced are made from polyacrylonitrile. The remaining 10% are made from rayon or petroleum pitch. All of these materials are organic polymers, characterized by long strings of molecules bound together by carbon atoms. The exact composition of each precursor varies from one company to another and is generally considered a trade secret. During the manufacturing process, a variety of gases and liquids are used. Some of these materials are designed to react with the fiber to achieve a specific effect. Other materials are designed not to react or to prevent certain reactions with the fiber. As with the precursors, the exact compositions of many of these process materials are considered trade secrets.

The Manufacturing Process PAN

Figure 1

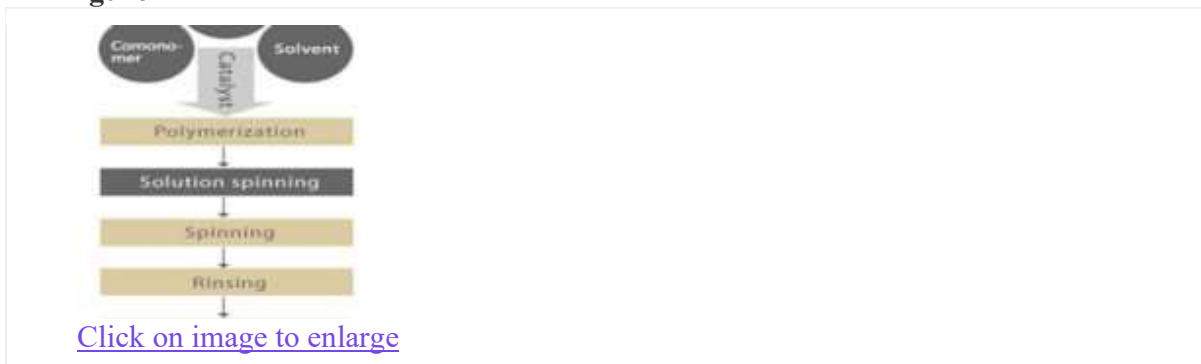

Spinning

- Acrylonitrile plastic powder is mixed with another plastic, like methyl acrylate or methyl methacrylate, and is reacted with a catalyst in a conventional suspension or solution polymerization process to form a polyacrylonitrile plastic.
- The plastic is then spun into fibers using one of several different methods. In some methods, the plastic is mixed with certain chemicals and pumped through tiny jets into a chemical bath or quench chamber where the plastic coagulates and solidifies into fibers. This is similar to the process used to form polyacrylic textile fibers. In other methods, the plastic mixture is heated and pumped through tiny jets into a chamber where the solvents evaporate, leaving a solid fiber. The spinning step is important because the internal atomic structure of the fiber is formed during this process.
- The fibers are then washed and stretched to the desired fiber diameter. The stretching helps align the molecules within the fiber and provide the basis for the formation of the tightly bonded carbon crystals after carbonization.

Stabilizing

Before the fibers are carbonized, they need to be chemically altered to convert their linear atomic bonding to a more thermally stable ladder bonding. This is accomplished by heating the fibers in air to about 390-590° F (200-300° C) for 30-120 minutes. This causes the fibers to pick up oxygen molecules from the air and rearrange their atomic bonding pattern. The stabilizing chemical reactions are complex and involve several steps, some of which occur simultaneously. They also generate their own heat, which must be controlled to avoid overheating the fibers. Commercially, the stabilization process uses a variety of equipment and techniques. In some processes, the fibers are drawn through a series of heated chambers. In others, the fibers pass over hot rollers and through beds of loose materials held in suspension by a flow of hot air. Some processes use heated air mixed with certain gases that chemically accelerate the stabilization.

Carbonizing

Once the fibers are stabilized, they are heated to a temperature of about 1,830-5,500° F (1,000-3,000° C) for several minutes in a furnace filled with a gas mixture that does not contain oxygen. The lack of oxygen prevents the fibers from burning in the very high temperatures. The gas pressure inside the furnace is kept higher than the outside air pressure and the points where the fibers enter and exit the furnace are sealed to keep oxygen from entering. As the fibers are heated, they begin to lose their non-carbon atoms, plus a few carbon atoms, in the form of various gases including water vapor, ammonia, carbon monoxide, carbon dioxide, hydrogen, nitrogen, and others. As the non-carbon atoms are expelled, the remaining carbon atoms form tightly bonded carbon crystals that are aligned more or less parallel to the long axis of the fiber. In some processes, two furnaces operating at two different temperatures are used to better control the rate of heating during carbonization.

Figure 2

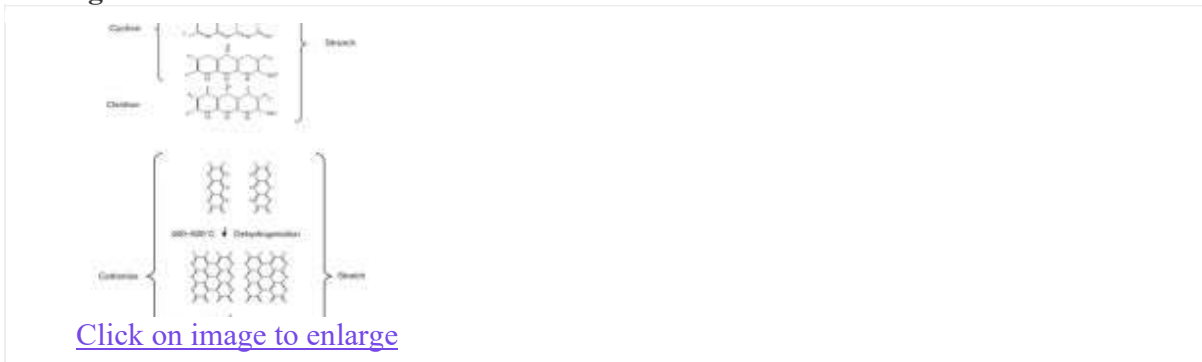

Treating the surface

After carbonizing, the fibers have a surface that does not bond well with the epoxies and other materials used in composite materials. To give the fibers better bonding properties, their surface is slightly oxidized. The addition of oxygen atoms to the surface provides better chemical bonding properties and also etches and roughens the surface for better mechanical bonding properties. Oxidation can be achieved by immersing the fibers in various gases such as air, carbon dioxide, or ozone; or in various liquids such as sodium hypochlorite or nitric acid. The fibers can also be coated electrolytically by making the fibers the positive terminal in a bath filled with various electrically conductive materials. The surface treatment process must be carefully controlled to avoid forming tiny surface defects, such as pits, which could cause fiber failure.

Sizing

- After the surface treatment, the fibers are coated to protect them from damage during winding or weaving. This process is called sizing. Coating materials are chosen to be compatible with the adhesive used to form composite materials. Typical coating materials include epoxy, polyester, nylon, urethane, and others.
- 8 The coated fibers are wound onto cylinders called bobbins. The bobbins are loaded into a spinning machine and the fibers are twisted into yarns of various sizes.

Properties

Carbon Fiber has High Strength to Weight Ratio (also known as specific strength)

Strength of a material is the force per unit area at failure, divided by its density. Any material that is strong AND light has a favourable Strength/weight ratio. Materials such as Aluminium, titanium, magnesium, Carbon and glass fiber, high strength steel alloys all have good strength to weight ratios.

Carbon Fiber is very Rigid

Rigidity or stiffness of a material is measured by its Young Modulus and measures how much a material deflects under stress. Carbon fiber reinforced plastic is over 4 times stiffer than Glass reinforced plastic, almost 20 times more than pine, 2.5 times greater than aluminium.

Carbon fiber is Corrosion Resistant and Chemically Stable

Although carbon fiber themselves do not deteriorate, Epoxy is sensitive to sunlight and needs to be protected. Other matrices (whatever the carbon fiber is imbedded in) might also be reactive.

Carbon fiber is Electrically Conductive

This feature can be useful and be a nuisance. In Boat building It has to be taken into account just as Aluminium conductivity comes into play. Carbon fiber conductivity can facilitate Galvanic Corrosion in fittings. Careful installation can reduce this problem.

Fatigue Resistance is good

Resistance to Fatigue in Carbon Fiber Composites is good. However when carbon fiber fails it usually fails catastrophically without much to announce its imminent break. Damage in tensile fatigue is seen as reduction in stiffness with larger numbers of stress cycles, (unless the temperature is high) Test have shown that failure is unlikely to be a problem when cyclic stresses coincide with the fiber orientation. Carbon fiber is superior to E glass in fatigue and static strength as well as stiffness.

Carbon Fiber has good Tensile Strength

Tensile strength or ultimate strength, is the maximum stress that a material can withstand while being stretched or pulled before necking, or failing. Necking is when the sample cross-section starts to significantly contract. If you take a strip of plastic bag, it will stretch and at one point will start getting narrow. This is necking. It is measured in Force per Unit area. Brittle materials such as carbon fiber does not always fail at the same stress level because of internal flaws. They fail at small strains.

Testing involves taking a sample with a fixed cross-section area, and then pulling it gradually increasing the force until the sample changes shape or breaks. Fibers, such as carbon fibers, being only 2/10,000th of an inch in diameter, are made into composites of appropriate shapes in order to test.

Fire Resistance/Non Flamable

Depending upon the manufacturing process and the precursor material, carbon fiber can be quite soft and can be made into or more often integreted into protective clothing for firefighting. Nickel coated fiber

is an example. Because carbon fiber is also chemically very inert, it can be used where there is fire combined with corrosive agents. Carbon Fiber Fire Blanket excuse the typos.

Thermal Conductivity of Carbon Fiber

Thermal conductivity is the quantity of heat transmitted through a unit thickness, in a direction normal to a surface of unit area, because of a unit temperature gradient, under steady conditions. In other words its a measure of how easily heat flows through a material.

Because there are many variations on the theme of carbon fiber it is not possible to pinpoint exactly the thermal conductivity. Special types of Carbon Fiber have been specifically designed for high or low thermal conductivity. There are also efforts to Enhance this feature.

Low Coefficient of Thermal Expansion

This is a measure of how much a material expands and contracts when the temperature goes up or down. Units are in Inch / inch degree F, as in other tables, the units are not so important as the comparison. In a high enough mast differences in Coefficients of thermal expansion of various materials can slightly modify the rig tensions. Low Coefficient of Thermal expansion makes carbon fiber suitable for applications where small movements can be critical. Telescope and other optical machinery is one such application.

Non Poisonous, Biologically Inert, X-Ray Permeable

These qualities make Carbon fiber useful in Medical applications. Prosthesis use, implants and tendon repair, x-ray accessories surgical instruments, are all in development. Although not poisonous, the carbon fibers can be quite irritating and long term unprotected exposure needs to be limited. The matrix either epoxy or polyester, can however be toxic and proper care needs to be exercised.

Carbon Fiber is Relatively Expensive

Although it offers exceptional advantages of Strength, Rigidity and Weight reduction, cost is a deterrent. Unless the weight advantage is exceptionally important, such as in aeronautics applications or racing, it often is not worth the extra cost. The low maintenance requirement of carbon fiber is a further advantage.

It is difficult to quantify cool and fashionable. Carbon fiber has an aura and reputation which makes consumers willing to pay more for the cachet of having it. You might need less of it compared to fiberglass and this might be a saving.

Carbon Fibers are brittle

The layers in the fibers are formed by strong covalent bonds. The sheet-like aggregations readily allow the propagation of cracks. When the fibers bend they fails at very low strain.

Applications

Characteristics and Applications of Carbon Fibers

1. Physical strength, specific toughness, light weight	Aerospace, road and marine transport, sporting goods
2. High dimensional stability, low coefficient of thermal expansion, and low abrasion	Missiles, aircraft brakes, aerospace antenna and support structure, large telescopes, optical benches, waveguides

	for stable high-frequency (GHz) precision measurement frames
3. Good vibration damping, strength, and toughness	Audio equipment, loudspeakers for Hi-fi equipment, pickup arms, robot arms
4. Electrical conductivity	Automobile hoods, novel tooling, casings and bases for electronic equipments, EMI and RF shielding, brushes
5. Biological inertness and x-ray permeability	Medical applications in prostheses, surgery and x-ray equipment, implants, tendon/ligament repair
6. Fatigue resistance, self-lubrication, high damping	Textile machinery, general engineering
7. Chemical inertness, high corrosion resistance	Chemical industry; nuclear field; valves, seals, and pump components in process plants
8. Electromagnetic properties	Large generator retaining rings, radiological equipment

Conducting Polymer:-

Polymers are poor conductors of electricity and generally used as electrical insulators and dielectric materials. However, there are polymers with improved electrical conductivity prepared by the addition of some additives such as conducting metals like copper and silver or other materials.

‘An organic polymer with highly delocalised Pi-electron system, having electrical conductance on par with metallic conductor is called a conducting polymer.’

For example: Polyacetylene, Polythiophene, Polyphenylene, Polyaniline.

Chemical structure:-

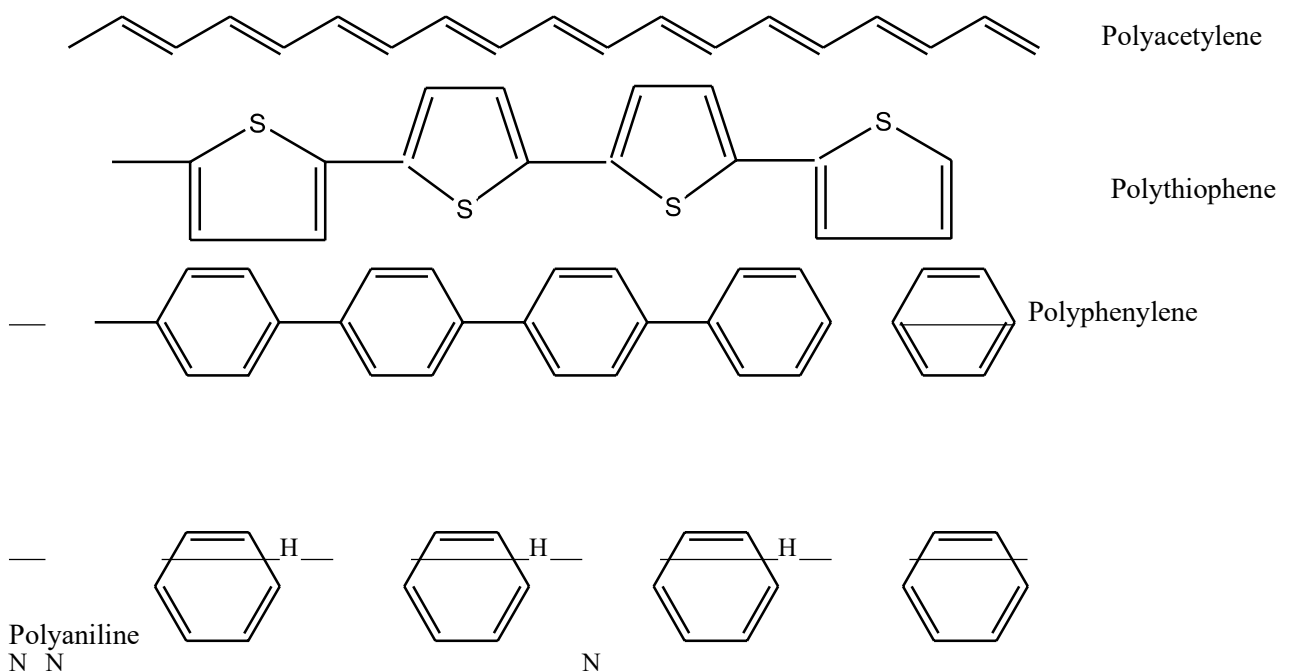

Classification:-

- i. Pi-electrons conducting polymers: The polymer whose backbone is made up of molecules that contain conjugated Pi-electrons which extend the entire polymer and made it conducting.
- ii. Conducting element filled polymer: Polymer filled with conducting elements such as carbon black, metallic fibres, metal oxides, etc. In this, the polymer acts as a binder to hold the conducting elements together in the solid entity.
- iii. Doped conducting polymer: It is obtained by exposing a polymer to a charge transfer agent in either gas phase or in solution.
- iv. Blended conducting polymer: It is obtained by blending a conventional polymer with a conducting polymer either by physical or chemical change.
- v. Inorganic or Coordination conducting polymer: It is a charge transfer complex containing polymer obtained by combining a metal atom with a polydentate ligand.

Synthesis:-

The conducting polymers like polyacetate and polyaniline can be synthesised by doping, in which charged species are introduced in organic polymers having Pi-electron backbone.

- i. **p-doping:** In this process, an intrinsically conducting polymer or conjugated Pi- electron conducting polymer is treating with Lewis acid. There by, oxidation takes place and creates positively charged sites on polymer backbone, which are current, carries for conduction. Some of the general P-dopant used are I₂, Br₂, AsF₃. etc.

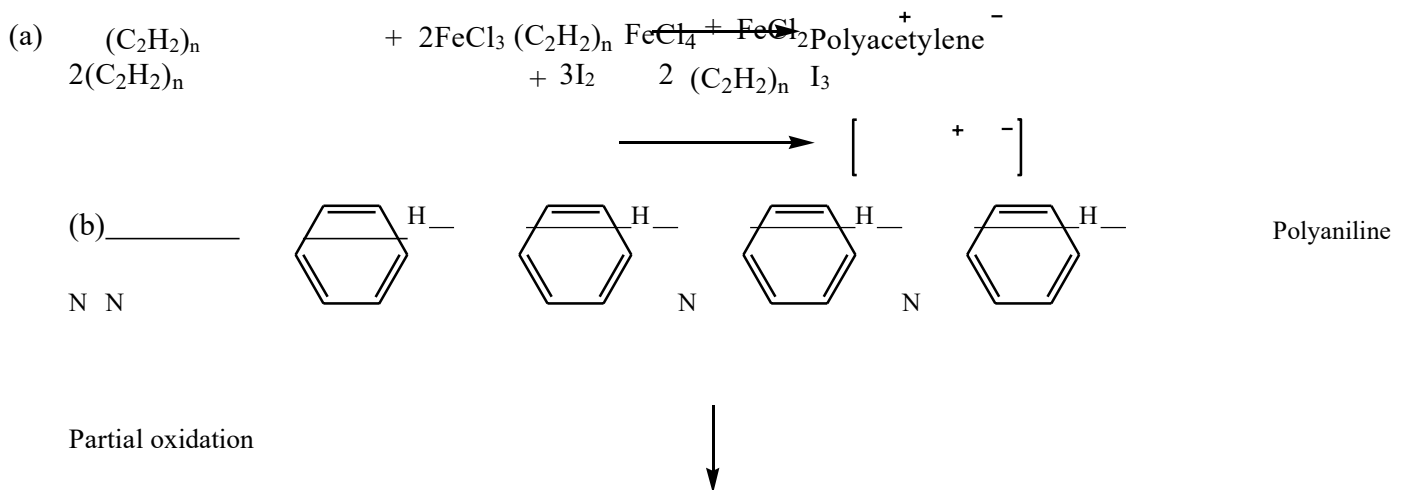

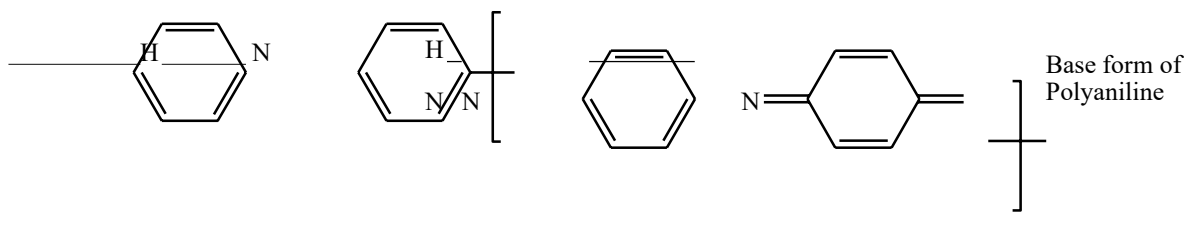

dil. HCl (Lewis acid) oxidation

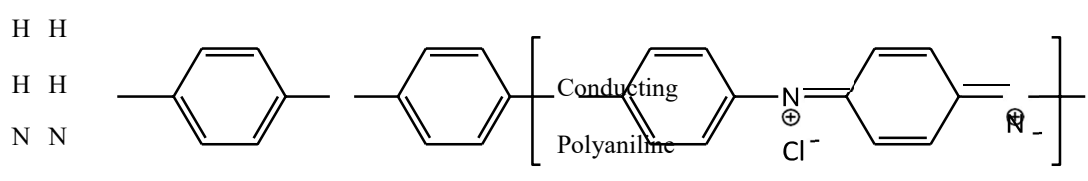

ii. n-doping: In this process, conjugated Pi-electrons are treated with Lewis base. There by, reduction takes place and creates negatively charged sites on polymer backbone, which are responsible for the conduction. Some of the general n-dopant used are Li, Na, Ca and tetrabutyl ammonium.

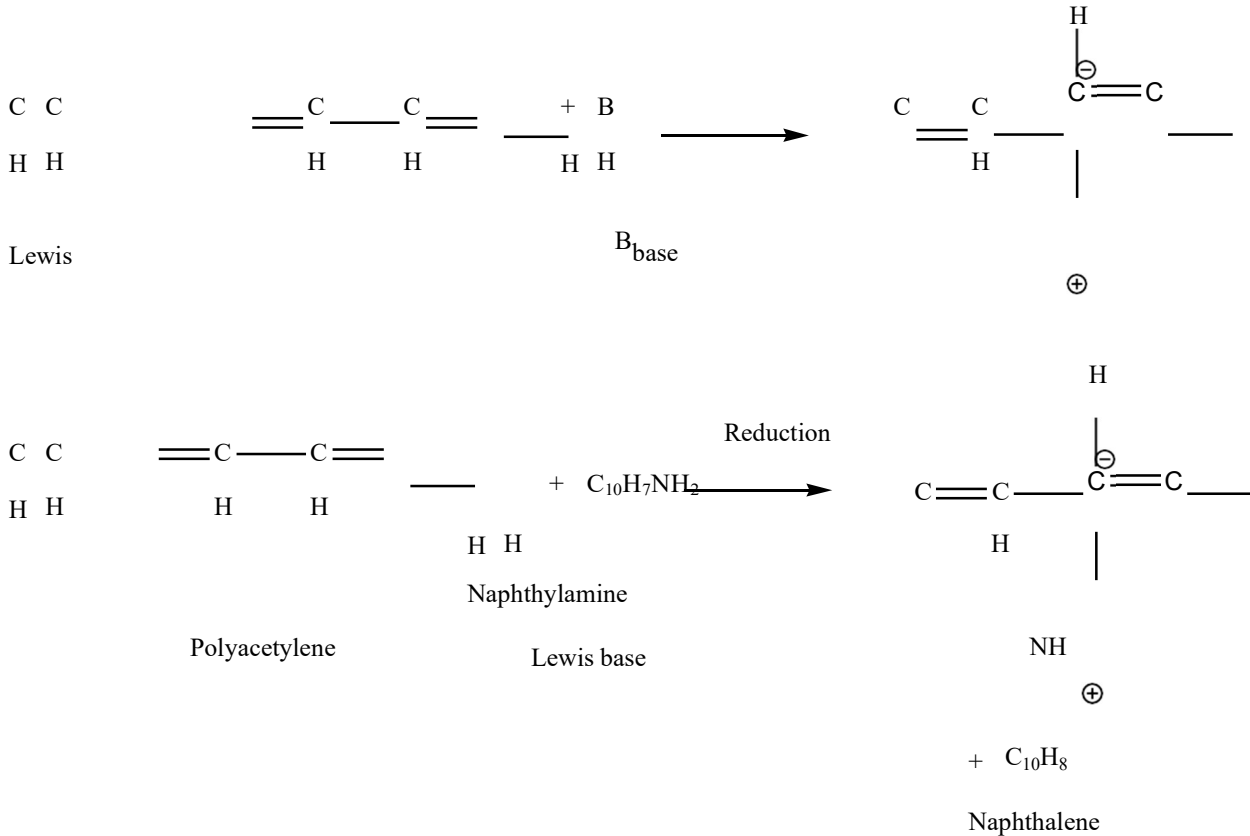

Application:-

Some of the important applications of conducting polymers are:

- i. In solar cells.
- ii. In photovoltaic devices.
- iii. In non-linear optical materials.
- iv. In telecommunication systems.
- v. As electrode material for commercial rechargeable batteries.
- vi. In antistatic coatings for clothing.
- vii. As film membranes for gas separations.
- viii. In wiring in aircrafts and aerospace components.
- ix. In fuel cells as the electro catalytic materials.

UNIT-IV: Advanced Engineering Materials Composites

Lecture notes

UNIT-V: INSTRUMENTAL METHODS AND APPLICATIONS

Lecture notes

Beer-Lambert's Law.

The Beer-Lambert law (or Beer's law) is the linear relationship between absorbance and concentration of an absorbing species. The general Beer-Lambert law is usually written as:

$A = a(\lambda) * b * c$ where A is the measured absorbance, $a(\lambda)$ is a wavelength-dependent absorption coefficient, b is the path length, and c is the analyze concentration. When working in concentration units of molarities, the Beer-Lambert law is written as:

$$A = \epsilon * b * c$$

where ϵ is the wavelength-dependent molar absorption coefficient with units of $M^{-1} \text{ cm}^{-1}$.

Derivation

When an object is exposed to radiation, some of the incident radiation is absorbed, some are scattered, and some are transmitted. As a result of absorption, the intensity of the substance that transmits light, i.e, the Intensity of transmitted light. The absorption part of the incident light depends on the thickness of the absorption medium. Lambert derived a quantitative relationship between the decrease in the intensity of monochromatic light passing through a homogeneous medium of thickness dx and the light intensity I . This law is known as Lambert's Law and can be given as. The decrease in light intensity due to the thickness of the absorbing medium at any point is directly proportional to the light intensity.

$$- dI / dx \propto I \quad \text{--- (1)}$$

Where dI is the slight decrease in light intensity when passing a small distance dx , and I is the intensity of monochromatic light just before entering the medium.

$$-dI / dx = aI \quad \text{--- (2)}$$

Where $-dI/dx$ is the rate of decrease in strength with thickness dx , and a is called the absorption coefficient.

By the integral of Eq. (2) after dislocation,

$$-\ln I = ax + C \quad \text{--- (3)}$$

Where C is the constant of integration. At $x = 0$, $I = I_0$. Therefore, $C = -\ln I_0$. Substituting this into equation (3) yields:

$$\ln I / I_0 = -ax \quad \text{--- (4)}$$

Equation (4) can also be written as,

$$I = I_0 e^{-ax} \quad \text{--- (5)}$$

Equation (5) can also be written as,

$$\log I / I_0 = -a / 2.303 x \quad \text{--- (6) or,}$$

$$\log I / I_0 = -a' x \quad \text{--- (7)}$$

Where a' ($= a / 2.303$) is the extinction coefficient and $-\ln I / I_0$ is the absorbance of the medium.

Absorbance is represented by A .

Absorbance is a dimensionless quantity that depends on the optical path length, the concentration of the absorbing substance, and the wavelength of the light.

Lambert-Beer's law shows that when light passes through a solution of a certain thickness, the rate at which incident light is absorbed depends not only on the intensity I of the light but also on the concentration c of the solution. Extended by Beer. This is known as Lambert-Beer's Law.

$$-dI / dx = a c I \quad \text{--- (8)}$$

$$\text{Combining the two laws } -dI / dx = b \times I \times c \quad \text{--- (9)}$$

When expressed, b is called the molar absorption coefficient.

As with Lambert's Law, equation (9) can be transformed as follows:

$$\log I / I_0 = -b / 2.303 \times c \times x \quad \text{---} \quad (10)$$

$$\log I / I_0 = -\epsilon \times c \times x \quad \text{---} \quad (11)$$

Here, ϵ ($= a / 2.303$) is called the molar extinction coefficient and is expressed in L/mol/cm.

Molar extinction coefficient: It measures the probability of electronic transitions. The higher the molar extinction coefficient, the higher the likelihood of electronic transitions. Molar extinction coefficient ϵ depends on the type of solute to be absorbed and the wavelength of the incident light used. Equation 11 is known as Beer-Lambert's Law.

Limitation of Beer-Lambert's law

1. Applicable only for dilute solutions.
2. Monochromatic radiation must be used.
3. The solute should not dissociate or associate in solution.
4. Not applicable to suspensions.
5. Solution should not contain impurities.

Principle, working and applications of Thin layer chromatography.

Thin Layer Chromatography is a technique used to isolate non-volatile mixtures. The experiment is conducted on a sheet of aluminium foil, plastic, or glass which is coated with a thin layer of adsorbent material. The material usually used is aluminium oxide, cellulose, or silica gel.

On completion of the separation, each component appears as spots separated vertically. Each spot has a retention factor (R_f) expressed as:

$$R_f = \text{dist. travelled by sample} / \text{dist. travelled by solvent}$$

The factors affecting retardation factor are the solvent system, amount of material spotted, adsorbent and temperature. TLC is one of the fastest, least expensive, simplest and easiest chromatography technique.

Thin Layer Chromatography Principle

Like other chromatographic techniques, thin-layer chromatography (TLC) depends on the

separation principle. The separation relies on the relative affinity of compounds towards both the phases. The compounds in the mobile phase move over the surface of the stationary phase. The movement occurs in such a way that the compounds which have a higher affinity to the stationary phase move slowly while the other compounds travel fast. Therefore, the separation of the mixture is attained. On completion of the separation process, the individual components from the mixture appear as spots at respective levels on the plates. Their character and nature are identified by suitable detection techniques.

Thin Layer Chromatography Diagram

THIN LAYER CHROMATOGRAPHY

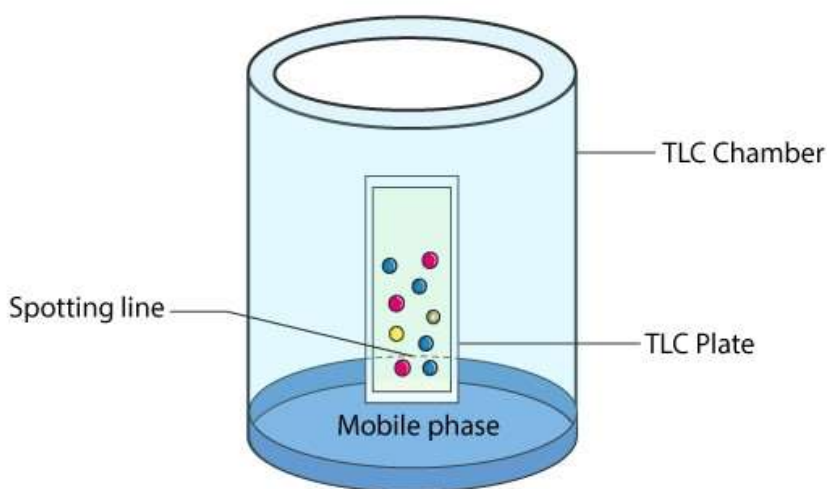

Diagram of Thin Layer Chromatography

Thin Layer Chromatography Procedure

Before starting with the Thin Layer Chromatography Experiment, let us understand the different components required to conduct the procedure along with the phases involved.

1. Thin Layer Chromatography Plates – ready-made plates are used which are chemically inert and stable. The stationary phase is applied on its surface in the form of a thin layer. The stationary phase on the plate has a fine particle size and also has a uniform thickness.
2. Thin Layer Chromatography Chamber – Chamber is used to develop plates. It is responsible to keep a steady environment inside which will help in developing spots. Also, it prevents the solvent evaporation and keeps the entire process dust-free.
3. Thin Layer Chromatography Mobile phase – Mobile phase is the one that moves and consists of a solvent mixture or a solvent. This phase should be particulate-free. The higher the quality of

purity the development of spots is better.

4. Thin Layer Chromatography Filter Paper – It has to be placed inside the chamber. It is moistened in the mobile phase.

Thin Layer Chromatography Experiment

- The stationary phase that is applied to the plate is made to dry and stabilize.
- To apply sample spots, thin marks are made at the bottom of the plate with the help of a pencil.
- Apply sample solutions to the marked spots.
- Pour the mobile phase into the TLC chamber and to maintain equal humidity, place a moistened filter paper in the mobile phase.
- Place the plate in the TLC chamber and close it with a lid. It is kept in such a way that the sample faces the mobile phase.
- Immerse the plate for development. Remember to keep the sample spots well above the level of the mobile phase. Do not immerse it in the solvent.
- Wait till the development of spots. Once the spots are developed, take out the plate and dry them. The sample spots can be observed under a UV light chamber.

Thin Layer Chromatography Applications

- The qualitative testing of various medicines such as sedatives, local anaesthetics, anticonvulsant tranquilisers, analgesics, antihistamines, steroids, hypnotics is done by TLC.
- TLC is extremely useful in biochemical analysis such as separation or isolation of biochemical metabolites from its blood plasma, urine, body fluids, serum, etc.
- Thin layer chromatography can be used to identify natural products like essential oils or volatile oil, fixed oil, glycosides, waxes, alkaloids, etc.
- It is widely used in separating multicomponent pharmaceutical formulations.
- It is used for the purification of samples and direct comparison is done between the sample and the authentic sample.
- It is used in the food industry, to separate and identify colours, sweetening agent, and preservatives
- It is used in the cosmetic industry.
- It is used to study if a reaction is complete.

Disadvantages Of Thin Layer Chromatography:

1. Thin Layer Chromatography plates do not have longer stationary phase.
2. When compared to other chromatographic techniques the length of separation is limited.
3. The results generated from TLC are difficult to reproduce.
4. Since TLC operates as an open system, some factors such as humidity and temperature can affect the final outcome of the chromatogram.
5. The detection limit is high and therefore if you want a lower detection limit, you cannot use TLC.
6. It is only a qualitative analysis technique and not quantitative.

Principle and instrumentation of IR spectroscopy:

There are two types of fundamental vibrations in a molecule.

1) Stretching vibration

In this vibration, the bonds are lengthened and compressed. But the bond angle remains unchanged. There are two kinds of stretching vibrations:

i) Symmetric stretching

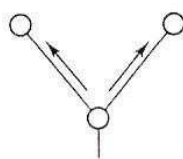

ii) Asymmetric stretching

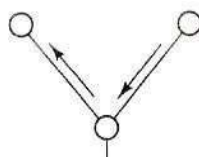

2) Bending or deformation vibrations

In this vibration, the bond angle increases and decreases but the bond length does not change. Bending vibrations are of two kinds.

i) In plane bending vibrations: Here all the atoms are in the same plane during vibration.

ii) Out of plane bending vibration: Here the atoms go out of plane during vibration.

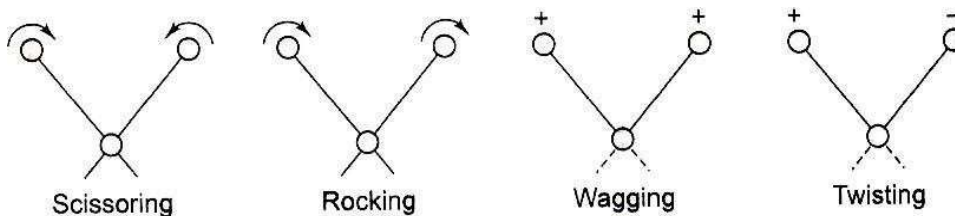

Inplane bending

Outofplanebending

Number of modes of vibrations

i) A linear molecule has $(3n-5)$ fundamental vibrational modes . n =number of atoms in a molecule.

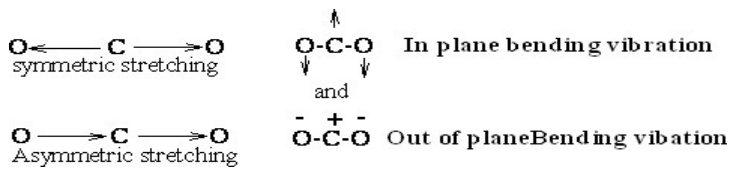

(e.g.) CO₂ is a linear molecule.

It can exhibit $3 \times 3 - 5 = 4$ vibrations. They are shown above.

ii) A non-linear molecule has $(3n-6)$ fundamental vibrational modes. n=number of atoms in the molecule.

(e.g.) Water (H₂O) is a non-linear molecule. It has $(3n-6) = 3 \times 3 - 6 = 3$ vibrational modes. They are shown below.

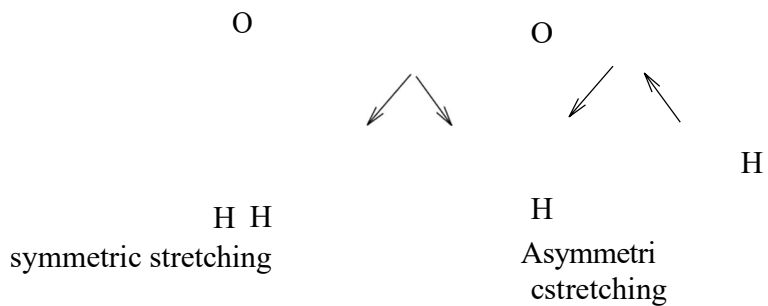

Instrumentation of IR Spectrometer

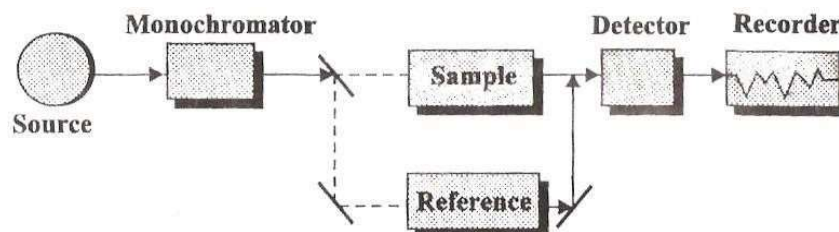

Block diagram of double beam IR spectrophotometer.

Components

I) Radiation Source

Nichrome wire and Nernst glower are the main sources of IR radiation. Nernst glower is filament made of oxides of Zr, Th and Ce held together using a binder.

i) Monochromator

It permits only radiation of desired wavelength to pass through and absorbs other wave lengths.

ii) Cell

The cell holding the sample solutions should be transparent to IR radiation.

NaCl cells are used.

iii) Detector

The IR radiation falling on the detector is converted into an electric signal.

Some detectors are:

- i) Thermocouple
- ii) Pyroelectric detectors

iv) Recorder

The electrical signal from the detector is recorded as percent transmittance against wavelength.

Working

The radiation from the source is split into two beams of equal intensity. One beam passes through the sample and the other through the reference.

When the sample absorbs, the two emerging beams will have different intensities. This produces an oscillating signal to be measured by the detector.

The signal from the detector gets amplified and goes to the recorder which gives a printout or display.

Principle & instrumentation of UV-visible spectroscopy with neat diagram.

Principle

UV-Visible spectroscopy involves transition of valence electrons of molecules or ions from the ground electronic state E_0 to a higher electronic state E_1 . The ultraviolet region is 100 to 400 nm.

The visible region is 400 to 800 nm. The amount of energy required for the transition is,

$$\Delta E = h\nu = E_1 - E_0$$

Type of transitions involved in organic molecules

There are three types of electrons in organic molecules - σ bonded electrons, π bonded electrons and non-bonded electrons (n). All the three types of electrons are present in formaldehyde:

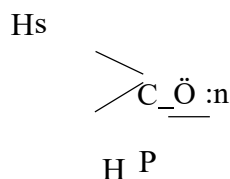

The types of transitions and their order of energies are:

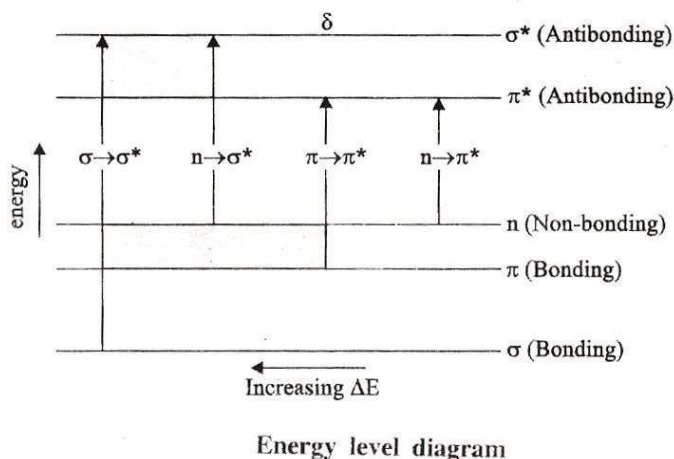

1. n → π* transitions

These are shown by unsaturated molecules with heteroatoms like N, O, S and halogen. They are due to the excitation of an electron from non-bonding lone pair (n) to an empty anti-bonding π* orbital.

Example:

Acetaldehyde and acetone

n → π* transition occurs at 270 to 300 nm. An electron from the non-bonding orbital of oxygen atom is excited to a π* orbital.

2. π → π* transitions

These are shown by molecules with π electrons. (e.g.) olefins, aromatic compounds. They are due to the excitation of an electron from π bonding orbital to anti-bonding π* orbital.

Example:

Ethylene $\text{CH}_2=\text{CH}_2$

A π → π* transition occurs at 200 nm.

3. n → σ* transitions

These are shown by saturated compounds containing a lone pair of electrons. They are due to the excitation of an electron from non-bonding orbital (n) to a σ* anti-bonding orbital.

Example:

Trimethylamine $(\text{CH}_3)_3\text{N}$:

$n \rightarrow s^*$ transition occurs at 227 nm. An electron from the non-bonding orbital of 'N' atom is excited to a s^* orbital.

3. $\sigma \rightarrow \sigma^*$ transitions

These are shown by all saturated compounds. They are due to the excitation of an electron from bonding orbital to σ^* anti-bonding orbital.

Example: CH_4

$\sigma \rightarrow \sigma^*$ transition occurs at 122 nm. $\sigma \rightarrow \sigma^*$ are high energy transitions.

They are weak, and usually not observed.