

MANUFACTURING TECHNOLOGY LAB MANUAL



Department of Mechanical Engineering

**VEMU INSTITUTE OF
TECHNOLOGY::P.KOTHAKOTA**
NEAR PAKALA, CHITTOOR-517112
**(APPROVED BY AICTE, NEW DELHI & AFFILIATED
TO JNTUA, ANANTAPURAMU)**

MANUFACTURING TECHNOLOGY LAB MANUAL



Name: _____

H.T.No: _____

Year/Semester: _____

Department of Mechanical Engineering

**VEMU INSTITUTE OF
TECHNOLOGY::P.KOTHAKOTA**

NEAR PAKALA, CHITTOOR-517112

**(APPROVED BY AICTE, NEW DELHI & AFFILIATED
TO JNTUA, ANANTAPURAMU)**

**JAWAHARLAL NEHRU TECHNOLOGICAL UNIVERSITY
ANANTAPUR**

20A03403P MANUFACTURING TECHNOLOGY LAB

1. Demonstration of construction & operations of general purpose machines:

Lathe, Drilling machine, Milling machine, Shaper, Planning machine, Slotting machine, Cylindrical Grinder, Surface grinder and Tool & cutter grinder.

2. Job on Step turning and taper turning on lathe machine

3. Job on Thread cutting and knurling on -lathe machine.

4. Job on Drilling and Tapping

5. Job on Shaping and Planning

6. Job on Slotting

7. Job on Milling (groove cutting/ gear cutting)

8. Job on Cylindrical and Surface Grinding

9. Job on Grinding of Tool angles

Department of Mechanical Engineering

VEMU INSTITUTE OF TECHNOLOGY:P.KOTHAKOTA

Vision of the Department:

To become a Centre of excellence in the field of Mechanical Engineering by producing professional graduates with technical knowledge, research, consultancy and entrepreneurial skills along with leadership qualities, ethics and lifelong learning to cater the needs of the society.

Mission of the Department:

- ✓ To impart quality education and training to nurture globally competitive mechanical engineers by state-of-the art laboratories and core instructions through eminent faculty members.
- ✓ To establish linkages with Premiere industries and research organizations to bring excellence in technical problem solving skills, research and consultancy services.
- ✓ To empower the graduates globally competent with creative thinking, leadership skills, lifelong learning, spirit of entrepreneurship, social and ethical values by offering value based education.

Course Outcomes

After completion of the course, students will be able to:

CO numbers	CO	POs	BTL
1	Evaluate step turning, knurling, taper turning on a lathe machine.	1,2,3,8,9	5
2	Evaluate the drilling and boring operations.	1,2,3,8,9	5
3	Evaluate gear cutting and groove cutting on milling machine.	1,2,3,8,9	5
4	Analyze planning, shaping, and slotting operations.	1,2,3,8,9	4
5	Analyze cylindrical and surface grinding operations.	1,2,3,8,9	4

CONTENTS**MANUFACTURING TECHNOLOGY LAB**

Sl. No.	Name of the Experiment	Page No.
1	DEMONSTRATION OF CONSTRUCTION AND OPERATIONS OF GENERAL PURPOSE MACHINES	1- 9
2	STEP TURNING ON LATHE	10-11
3	TAPER TURNING ON LATHE	12-13
4	THREAD CUTTING AND KNURLING ON LATHE	14-15
5	DRILLING AND TAPPING	16-17
6	JOB ON SHAPER	18-19
7	JOB ON SLOTTER	20
8	JOB ON MILLING	21-22
9	TAPER TURNING AND KNURLING ON LATHE	23-24
10	DRILLING AND BORING ON LATHE	25-26
11	JOB ON GRINDING OF TOOL ANGLES	27-29

INSTRUCTIONS TO STUDENTS

DO'S

1. Learn objective & significance of the practical.
2. Keep silence in the lab.
3. Always perform the experiment or work precisely as directed by teacher
4. Don't forget to bring calculator, graph sheet and other accessories when you come to lab.
5. Before performing practical's read instrument manual carefully.
6. Count all accessories before receiving equipments in lab.
7. Before performing practical's read instrument manual carefully.

DONT'S

1. Don't use mobile phones during lab hours.
2. Don't try to repair any faulty instrument.
3. Don't run machine without permission.

SCHEME OF EVALUATION

S. No	Experiment	Date	Marks Awarded				Total 30(M)
			Record (10M)	Observation (10M)	VivaVoice (5M)	Attendance (5M)	
1.	DEMONSTRATION OF CONSTRUCTION AND OPERATIONS OF GENERAL PURPOSE MACHINES						
2.	STEP TURNING ON LATHE						
3.	TAPER TURNING ON LATHE						
4.	THREAD CUTTING AND KNURLING ON LATHE						
5.	DRILLING AND TAPPING						
6.	JOB ON SHAPER						
7.	JOB ON SLOTTER						
8.	JOB ON MILLING						
9.	TAPER TURNING AND KNURLING ON LATHE						
10.	DRILLING AND BORING ON LATHE						
11	JOB ON GRINDING OF TOOL ANGLES						

Signature of Lab In-charge

**DEMONSTRATION OF CONSTRUCTION & OPERATION OF
GENERAL PURPOSE MACHINES**

EXP NO:

DATE :

INTRODUCTION

Various machining purpose used these all type of mechanical machining machines are Lathe machine, Shaper machine, Slotting machine, Planning machine, Drilling machine, Boring machine, Milling machine, Grinding machine, Lapping machine Honing machine and Broaching machine.

These machines are to producing various operations like namely Facing, Chamfering, Step turning, Taper turning, Plain turning, Knurling, Grooving, Thread cutting, Drilling, Tapping, Precision grinding, Cylindrical grinding, Surface grinding, grinding of tool angles etc.

Lathe Machine

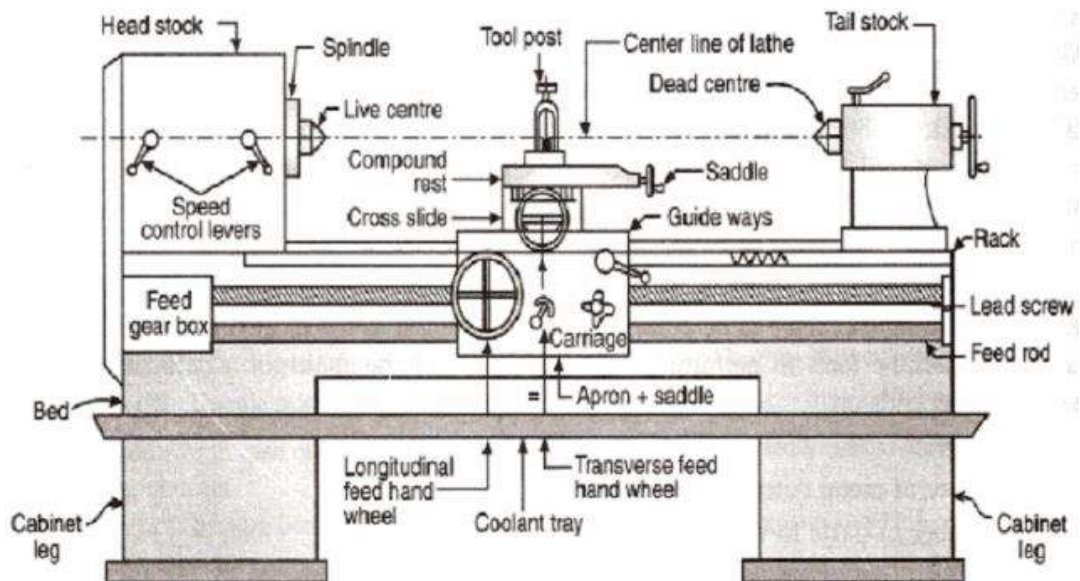

A lathe is a machine tool which rotates the workpiece on its axis to perform various operations such as cutting, sanding, knurling, drilling, or deformation with tools that are applied to the workpiece to create an object which has symmetry about an axis of rotation.

Lathes are used in woodturning, metalworking, metal spinning, and glass working. Lathes can be used to shape pottery, the best-known

design being the potter's wheel. Most suitably equipped metalworking lathes can also be used to produce most solids of revolution, plane surfaces and screw threads or helices. Ornamental lathes can produce three-dimensional solids of incredible complexity. The material can be held in place by either one or two centers, at least one of which can be moved horizontally to accommodate varying material lengths. Other work holding methods include clamping the work about the axis of rotation using a chuck to a faceplate, using clamps or dogs.

Operations on Lathe

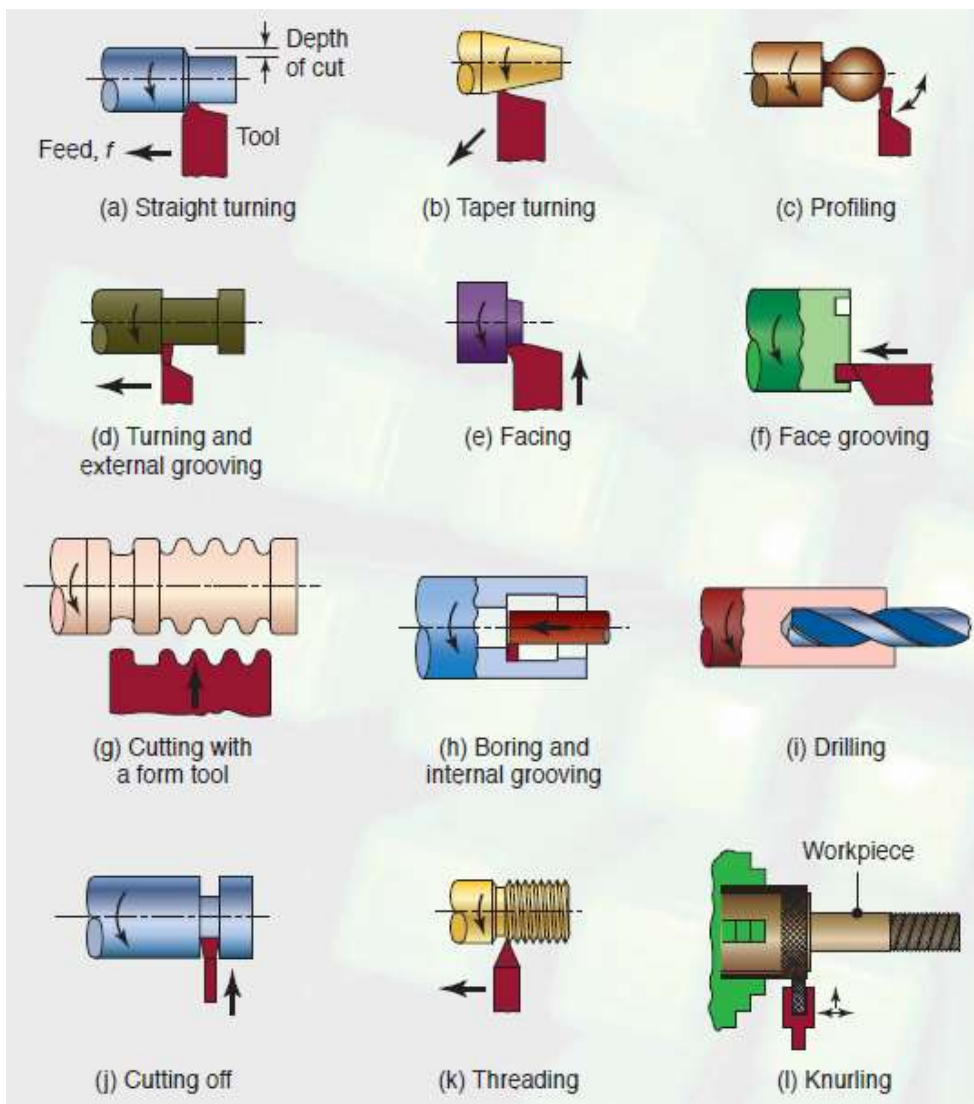

Shaping Machine

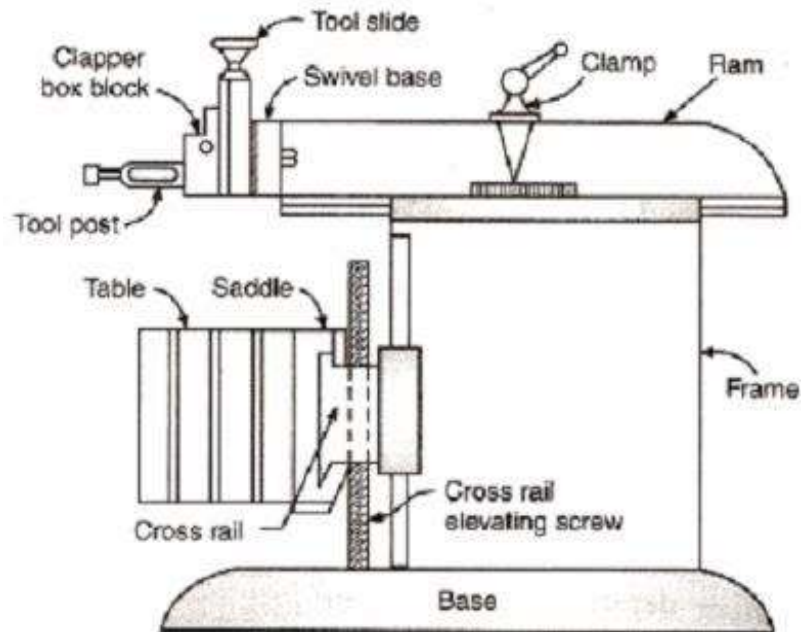

A shaper is a type of machine tool that uses linear relative motion between the work piece and a single- point cutting tool to machine a linear tool path. Its cut is analogous to that of a lathe, except that it is linear instead of helical. (Adding axes of motion can yield helical tool paths, as also done in helical planning.) A shaper is analogous to a planer, but smaller, and with the cutter riding a ram that moves above a stationary work piece, rather than the entire work piece moving beneath the cutter. The ram is moved back and forth typically by a crank inside the column; hydraulically actuated shapers also exist.

A shaper is a type of machine tool that uses linear relative motion between the work piece and a single- point cutting tool to machine a linear tool path. Its cut is analogous to that of a lathe, except that it is linear instead of helical. (Adding axes of motion can yield helical tool paths, as also done in helical planning.) A shaper is analogous to a planer, but smaller, and with the cutter riding a ram that moves above a stationary workpiece, rather than the entire workpiece moving beneath the cutter. The ram is moved back and forth typically by a crank inside the column; hydraulically actuated shapers also exist.

Operations on a Shaper

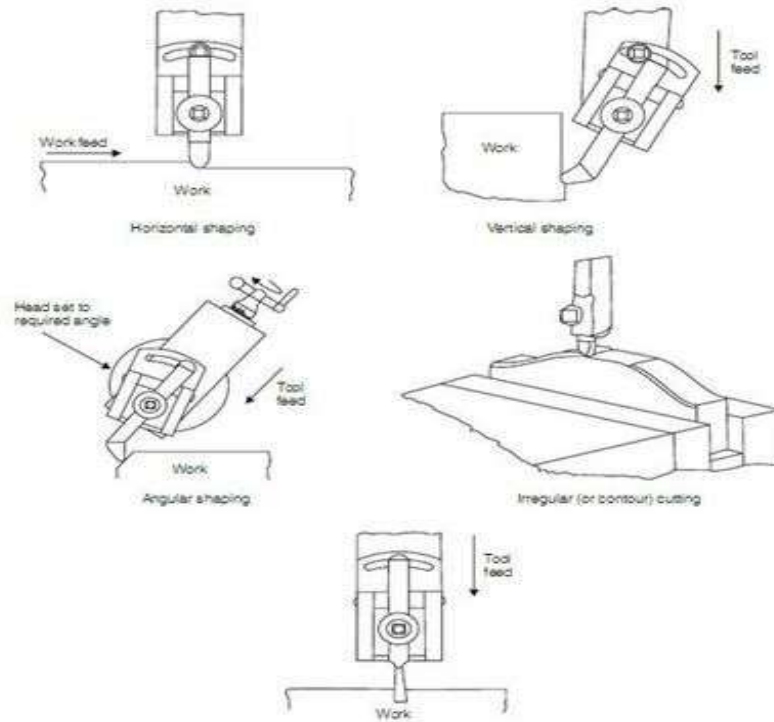

PLANNING MACHINE:

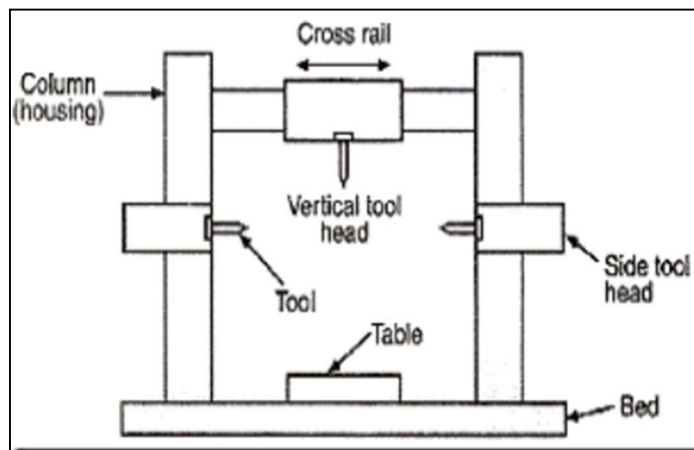

A planer is a type of metalworking machine tool that uses linear relative motion between the workpiece and a single-point cutting tool to machine a linear tool path. Its cut is analogous to that of a lathe, except that it is linear instead of helical. (Adding axes of motion can yield helical tool paths; see "Helical planing" below).

A planer is analogous to a shaper, but larger, and with the entire workpiece moving on a table beneath the cutter, instead of the cutter riding a ram that moves above a stationary workpiece. The table is

moved back and forth on the bed beneath the cutting head either by mechanical means, such as a rack and pinion drive or a leadscrew, or by a hydraulic cylinder.

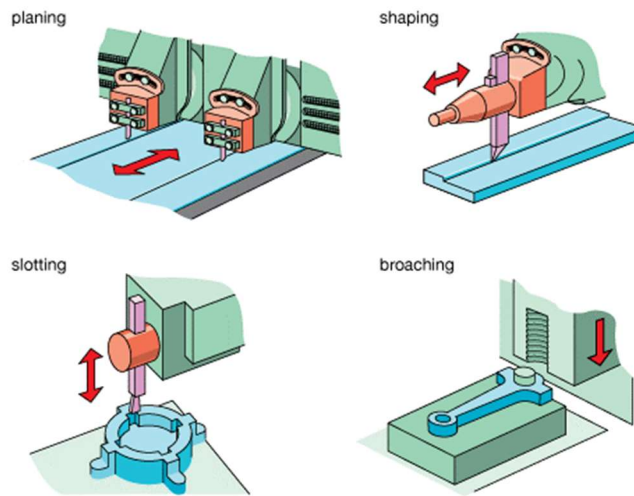

Common Planning Operations

Drilling Machine

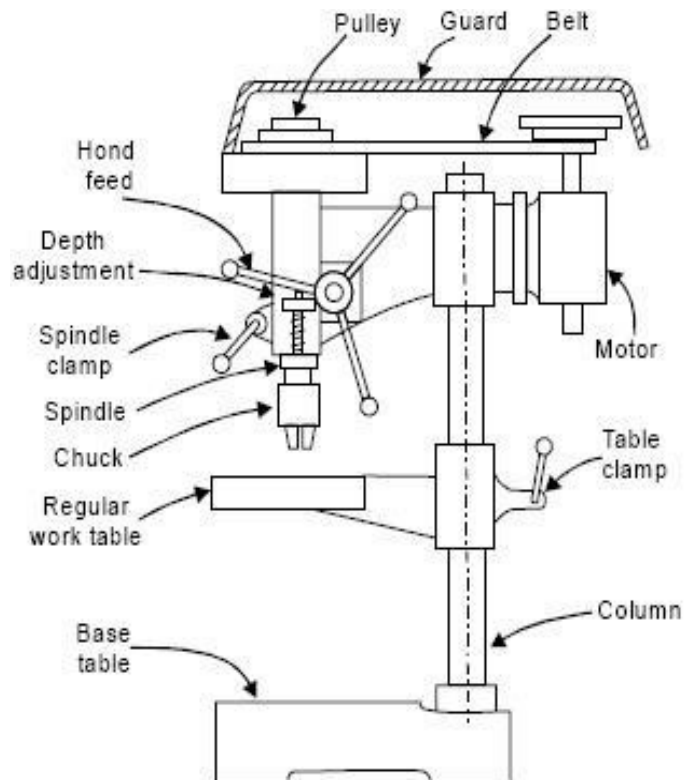

A drill or drill motor is a tool fitted with a cutting tool attachment or driving tool attachment, usually a drill bit or driver bit, used for drilling holes in various materials or fastening various materials together with the use of fasteners. The attachment is gripped by a chuck at one end of the

drill and rotated while pressed against the target material. The tip, and sometimes edges, of the cutting tool does the work of cutting into the target material. This may be slicing off thin shavings (twist drills or auger bits), grinding off small particles (oil drilling), crushing and removing pieces of the workpiece (SDS masonry drill), countersinking, counter boring, or other operations.

Drills are commonly used in woodworking, metalworking, construction and do-it-yourself projects. Specially designed drills are also used in medicine, space missions and other applications.

Operations on Drilling Machine

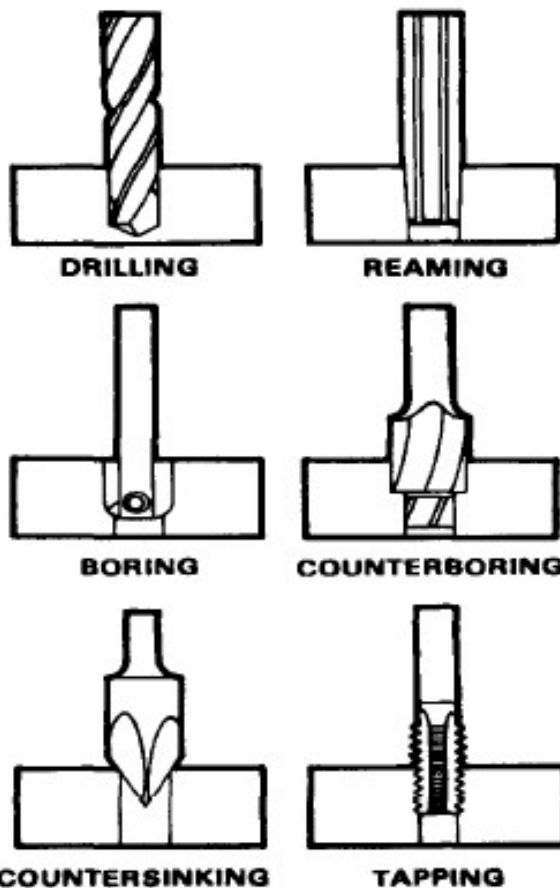

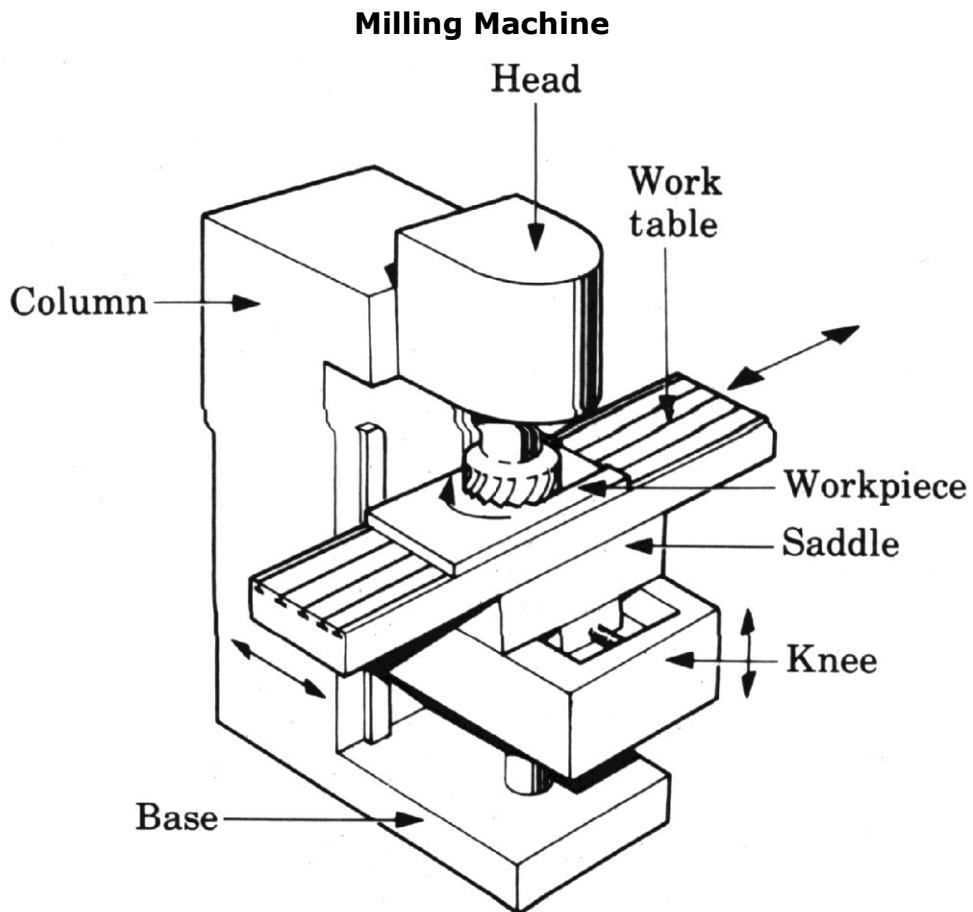

A milling machine (also see synonyms below) is a machine tool used to machine solid materials. Milling machines are often classed in two basic forms, horizontal and vertical, which refers to the orientation of the main spindle. Both types range in size from small, bench-mounted devices to room-sized machines. Unlike a drill press, this holds the workpiece stationary as the drill moves axially to penetrate the material, milling machines also move the workpiece radially against the rotating milling cutter, which cuts on its sides as well as its tip. Workpiece and cutter movement are precisely controlled to less than 0.001 in (0.025 mm), usually by means of precision ground slides and lead screws or analogous technology. Milling machines may be manually operated, mechanically automated, or digitally automated via computer numerical control (CNC).

Milling machines can perform a vast number of operations, from simple (e.g., slot and keyway cutting, planing, drilling) to complex (e.g., contouring, die sinking). Cutting fluid is often pumped to the cutting site to cool and lubricate the cut and to wash away the resulting swarf.

Operations on Milling Machine

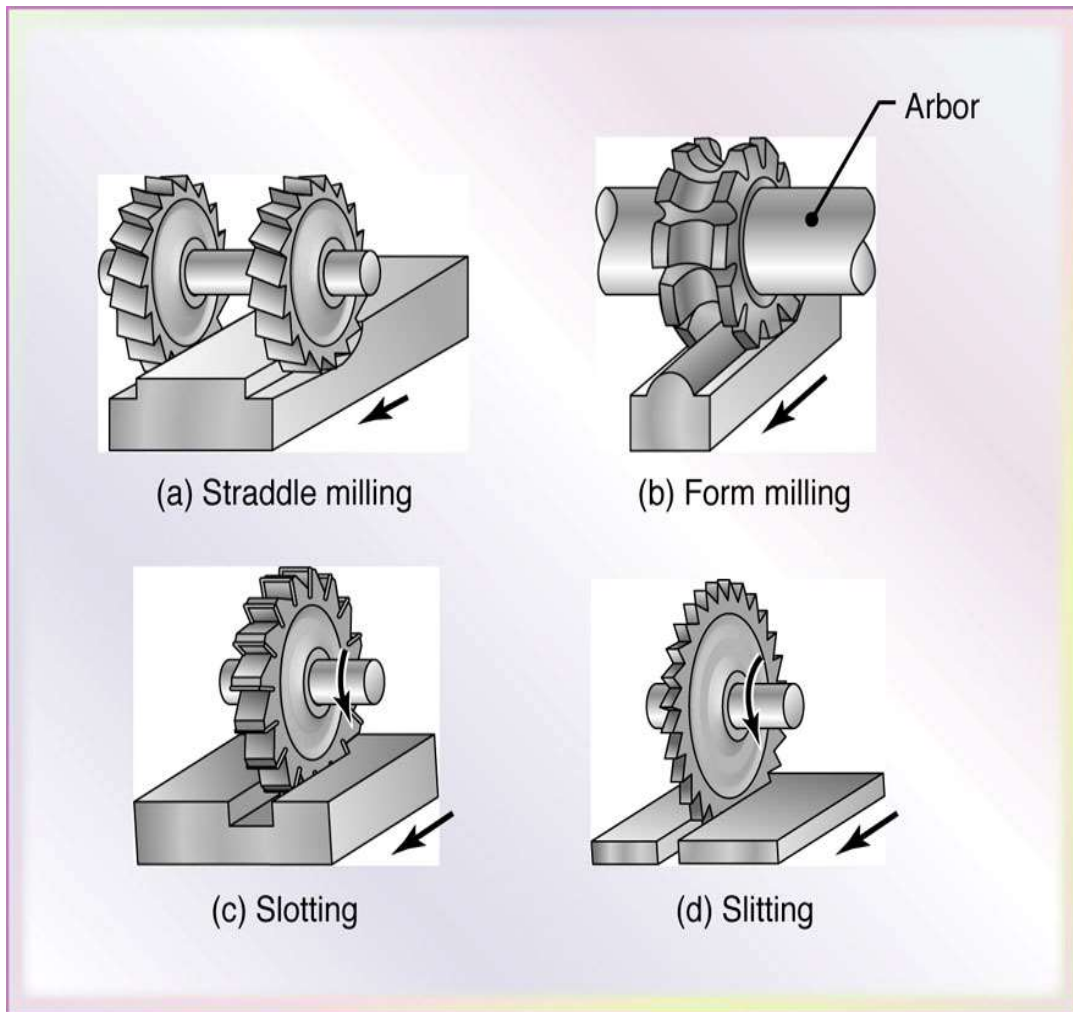

Grinding Machine

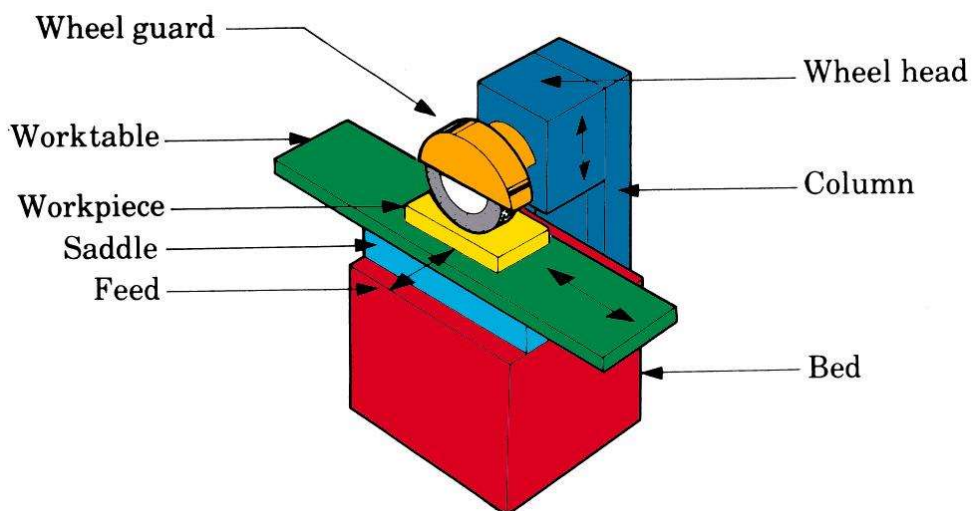

A grinding machine, often shortened to grinder, is a machine tool used for grinding, which is a type of machining using an abrasive wheel

as the cutting tool. Each grain of abrasive on the wheel's surface cuts a small chip from the workpiece via shear deformation.

The grinding machine consists of a power driven grinding wheel spinning at the required speed (which is determined by the wheel's diameter and manufacturer's rating, usually by a formula) and a bed with a fixture to guide and hold the work-piece. The grinding head can be controlled to travel across a fixed work piece or the workpiece can be moved whilst the grind head stays in a fixed position. Very fine control of the grinding head or tables position is possible using a Vernier calibrated hand wheel, or using the features of numerical controls.

STEP TURNING ON LATHE

EXP NO: 1

DATE :

AIM: To perform a step turning operation on the given cylindrical work piece.

APPARATUS:

1. Lathe with standard accessories.
2. Steel rule, Vernier Callipers.
3. Work piece – Mild steel Round rod of 1 inch Dia.

PRINCIPLE:

Turning is a lathe operation in which an external cylindrical surface is produced by the cutting tool. The cutting Tool is first adjusted for the desired depth of cut, using the cross slide. Then as the work piece rotates, the cutting tool is advanced relatively slowly in a direction parallel to the rotational axis of the spindle. The motion is known as the feed. These combined motions cause the work piece by adjusting the feed so that the helical path of the tool tip overlaps and generates a cylindrical surface on the work piece.

TOOLS:

Steel rule, outside calipers, tool holder with key, chuck key, HSS cutting Tool bit.

MATERIAL:

Mild Steel round rod of diameter 25 mm

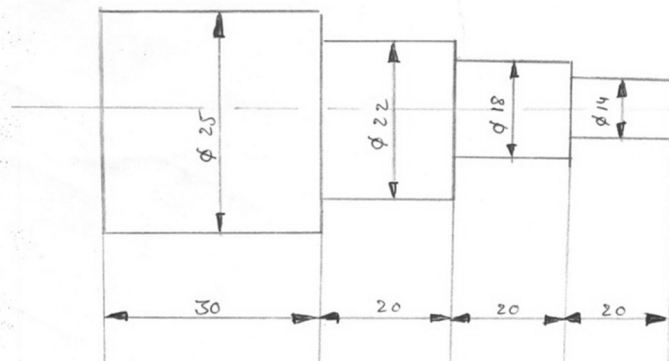

DIMENSIONS OF STEP TURNING

PROCEDURE:

- Initially the given work piece is fitted in the chuck using a chuck key.
- The high speed tool bit is positioned in the tool post and is kept at an angle to the axis of the given work piece.
- After this operation, the diameter of the work piece is to be reduced according to the given dimensions by turning process.
- While doing the work piece one end of the work piece is reduced to the required diameter.
- After turning, chamfering process is performed by turning the tool bit at 45° inclination and by bringing the tool in contact with the edge of the job, this process removes all sharp edges of the component.

PRECAUTIONS:

1. The chuck key must be removed immediately after the use.
2. The power supply switched off before measuring diameter.
3. Before performing facing they must be in same line.

RESULT:

TAPER TURNING ON LATHE

EXP NO: 2

DATE :

AIM: To perform taper turning operation by compound rest swiveling method on the given cylindrical work piece.

APPARATUS:

1. Lathe with standard accessories.
2. Steel rule, Vernier Callipers.
3. Work piece – Mild steel Round rod of 1 inch Dia.

PRINCIPLE:

Cutting Tapers on a lathe is common application. A number of methods are available for cutting tapers on a lathe.

They are:

1. Compound rest Swiveling Method.
2. Using form tools.
3. Tail stock offset method.
4. Taper attachment method.

These methods are used for turning steep and short tapers. There is a circular base graduated in degrees which can be swiveled at any angle from the center line of the lathe centers. The amount of taper in a work piece is usually specified by the ratio of the difference in diameters of the taper to its length. This is termed as conicity and is designated by the letter K.

$$\text{Conicity } K = (D-d) / (2xL)$$

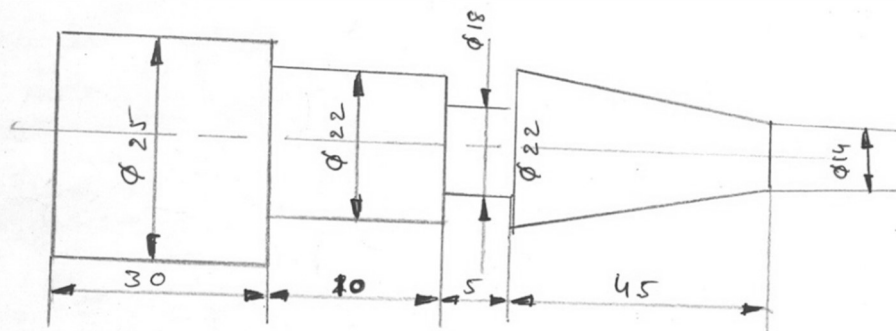

DIMENSIONS OF TAPER TURNING

PROCEDURE:

- The work piece is fixed in the tool post tightly.
- The center of head stock and tail stock is coincided with the centers of head stock and tail stock.
- Facing and plain turning operations are performed to get the required diameter on the work piece.
- The compound rest is set on the required half taper angle and is locked by the cutting rod is adjusted to a fixed position for the best possible to the open hand wheel and cross feed.
- Then the carriage is locked and first cut is made at the end of the cut, the tool is again cross fed is given for the next cut. Cuts are repeated piece is then removed from the chuck and dimensions obtained are noted.

PRECAUTIONS:

1. The work piece should be fixed tight in the jaw.
2. The power supply switched off before measuring diameters.

RESULT:

**RIGHT HAND SCREW THREAD CUTTING AND KNURLING
OPERATION ON LATHE**

EXP NO: 3

DATE :

AIM: To Obtain A Right Hand Screw Threading And Knurling On Workpiece Of Given Dimensions.

APPARATUS:

1. Lathe with standard accessories.
2. Steel rule, Vernier Callipers.
3. Work piece – Mild steel Round rod of 1 inch Dia.

PROCEDURE:

- The given work piece is fixed tightly in the 3 jaw chuck.
- Facing and turning operations are done to make the diameter equal to the major diameter of the screw thread.
- According to the given Pitch, the necessary gearing ratio is calculated. The feed selection lever that unlocks the half-nut lever for use, is set on the carriage apron for cutting metric threads, the included angle for the cutting edge should be ground exactly 60° .
- The thread cutting tool is fixed in the tool post so that the tip of the tool coincides with the axis of the workpiece the lathe spindle speed is reduced by on half, on forth of the speed required for turning by back gear mechanism or quick change levers.
- The half nut lever engaged at the end of the cut, the spirit nut lever disengages the carriage and the tool is withdrawn to its position sufficient depth is given for each cut using the cross slide the process is repeated till the required dimensions are obtained.

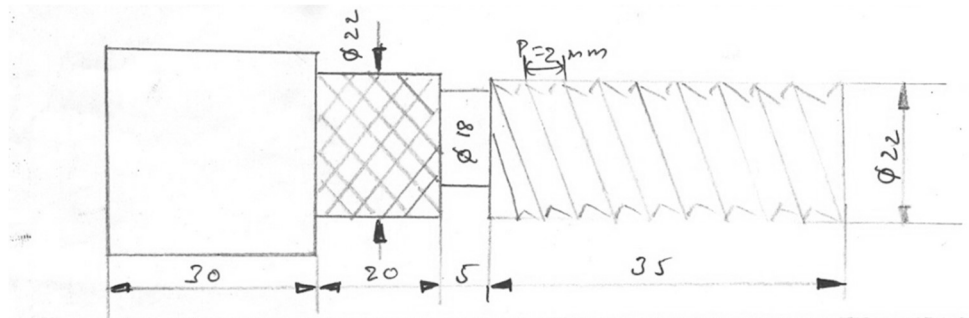

DIMENSIONS OF THREADING AND KNURLING

PRECAUTIONS:

1. For cutting right threads the change gears should be so arranged that the direction of the lead screw is in same direction as that of the rotation of spindle.
2. The work piece should be fixed tight in the jaw.
3. The power supply switched off before measuring diameters.

RESULT:

DRILLING AND TAPPING ON RADIAL DRILLING MACHINE

EXP NO:4

DATE :

AIM: To Perform Drilling And Tapping Operations On The Given M.S Flat Work Piece.

APPARATUS:

1. Drilling Machine with standard accessories
2. Steel rule, Vernier calipers.
3. Work piece – Mild Steel flat of 48 x 48 x 5 mm

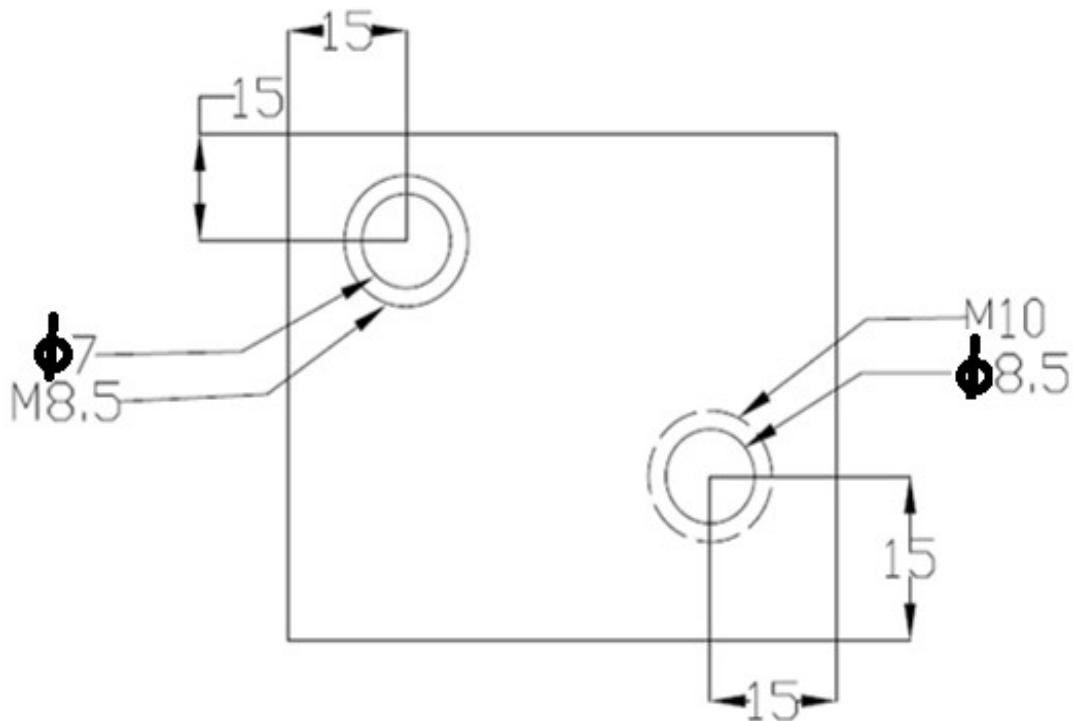

DIMENSIONS OF DRILLING AND TAPPING

PROCEDURE:

1. The given work piece is first filled to get required length, breadth and thickness.
2. wet chalk is applied on four sides and with the scribe lines are drawn to get center hole at required location.
3. The centers are punched with a Punch and hammer.
4. The work piece is fixed firmly in the vice of the Drilling Machine
5. Drill bit is fixed firmly in the chuck and drilling is performed for required depths.
6. The drill bit is removed from the drill chuck and is replaced by a reamer.
7. The reaming operation is performed on the hole which has been previously drilled.
8. The work is removed from the vice for performing tapping operation.
9. The job is fixed firmly in a bench vice.
10. Tap is fixed in the tap handle and pressure is applied on the taps to obtain internal thread.

PRECAUTIONS:

1. While performing tapping operations lubricant should be used to minimize friction.

RESULT:

JOB ON SHAPER

EXP NO: 5

DATE :

AIM: To Make A Square Block On Given Round Rod Work Piece.

APPARATUS:

1. Shaper with standard accessories.
2. Steel rule, Vernier Callipers.
3. Work piece – Aluminium Round rod of 60 mm Dia.

PROCEDURE:

1. Marking the dimensions on the work piece with steel rule and scriber
2. Fix the specimen in the vice of the shaping machine
3. Give the correct depth and feed for the slot is to be made manually.
4. Check the slot with the Vernier calipers precisely.

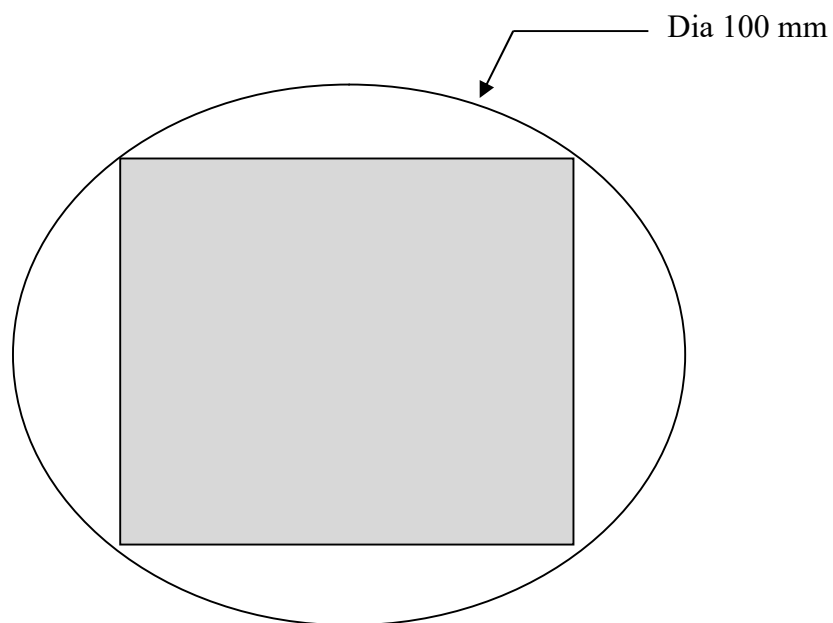

DIMENSIONS OF JOB ON SHAPER

PRECAUTIONS:

1. The shaping machine must be stopped before setting up or removing the work piece.
2. All the chips should be removed from the cutter.

RESULT:

JOB ON SLOTTER

EXP NO: 6

DATE :

AIM: To Make A Slot On The Given Work Piece.

APPARATUS:

1. Slotter with standard accessories.
2. Steel rule, Vernier Callipers.
3. Work piece – Mild steel Washer 1 ½ inch dia.

PROCEDURE:

1. Fix the work piece in the chuck firmly with the bolts.
2. Slotting tool is fixed in the tool holder and centering is to be done.
3. A slot of required depth is made according to dimensions manually.

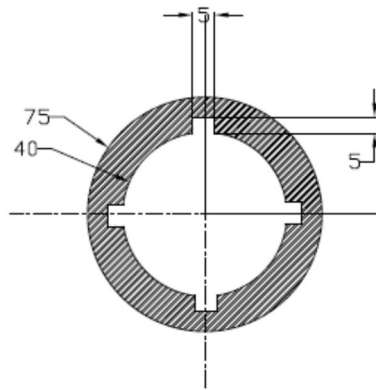

DIMENSIONS OF JOB ON SLOTTER

PRECAUTIONS:

1. Choose proper feed and depth of cut.
2. Feed should be controlled to avoid any damage to the cutting tool.
3. Lock the index table before starting the operation.
4. Care has to be taken so as to maintain the right feed of the material.

RESULT:

JOB ON MILLING MACHINE

EXP NO: 7

DATE :

AIM: To Perform Milling Operation On The Given Specimen As Per The Dimensions.

APPARATUS:

1. Milling Machine with standard accessories.
2. Steel rule, Vernier Callipers.
3. Work piece – Mild Steel flat of 48 x 48 x 5 mm

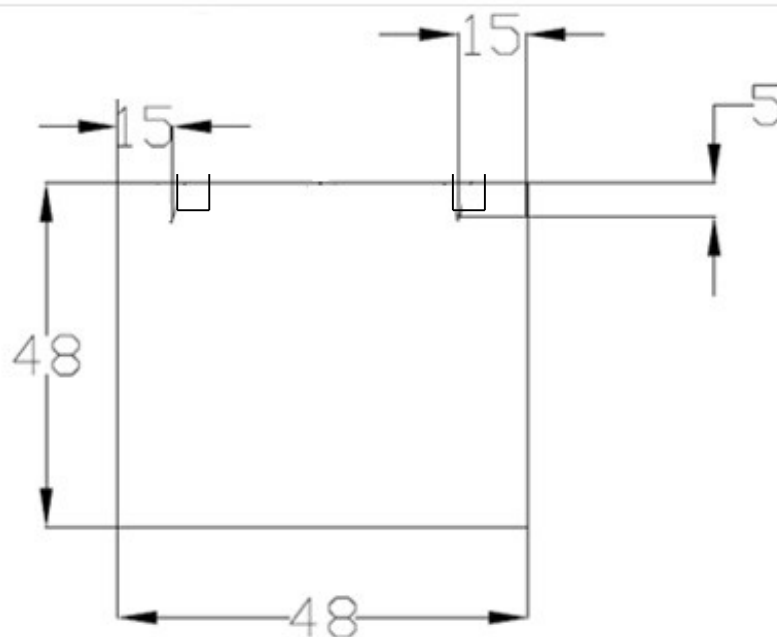

DIMENSIONS OF MILLING JOB

PROCEDURE:

1. File the workpiece as per the dimensions to get required length, breadth and thickness.
2. Wet chalk is applied on four sides of the work piece and mark the dimensions on the given work piece with the help of steel rule and scriber.
3. The given flat is fixed in the vice provided on the machine table such a, one end of it is projected outside the jaws of the vice.
4. A milling cutter is mounted on the horizontal milling machine spindle one end of the flat is milled, to the required depth by raising the table.
5. The burrs if any along the edges are removed with the help of the file.

PRECAUTIONS:

1. The milling machine must be stopped before setting up or removing a work piece, cutter or other accessory.
2. Never stop the feeding of job when the cutting operation is going on, otherwise the tool will cut deeper at the point where feed is stopped.
3. All the chips should be removed from the cutter. A wiping cloth should be placed on the cutter to protect the hands. The cutter should be rotated in the clockwise direction only for right handed tools.
4. Tool must be mounted as close to the machine spindle as possible.

RESULT:

TAPER TURNING AND KNURLING ON LATHE

EXP NO:8

DATE :

Aim: To perform Taper turning operation by Compound Rest Swiveling method on the given cylindrical work piece and knurling operation on the specified outer diameter on the given work piece.

Apparatus:

1. Lathe with standard accessories.
2. Steel rule, Vernier Callipers.
3. Work piece – Mild steel Round rod of 1 inch Dia.

Principle:

Cutting Tapers on a lathe is common application. A number of methods are available for cutting tapers on a lathe.

They are:

1. Compound rest Swiveling Method.
2. Using form tools.
3. Tail stock offset method.
4. Taper attachment method.

These methods are used for turning steep and short tapers. There is a circular base graduated in degrees which can be swiveled at any angle from the center line of the lathe centers. The amount of taper in a work piece is usually specified by the ratio of the difference in diameters of the taper to its length. This is termed as conicity and is designated by the letter K.

$$\text{Conicity } K = (D-d) / (2xL)$$

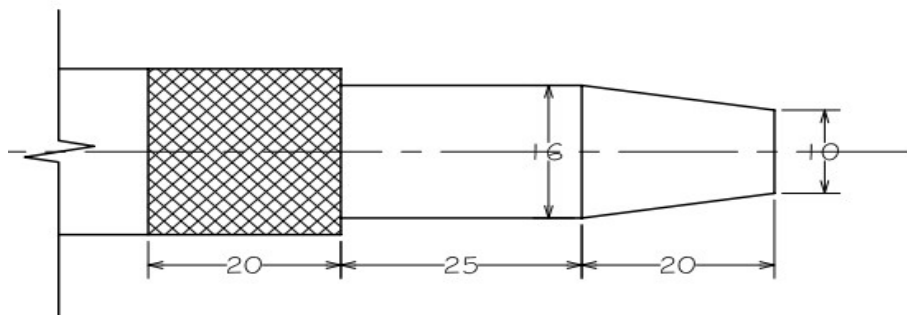

DIMENSIONS OF TAPER TURNING

Procedure:

- The work piece is fixed in the tool post tightly.
- The center of head stock and tail stock is coincided with the centers of head stock and tail stock.
- Facing and plain turning operations are performed to get the required diameter on the work piece.
- The compound rest is set on the required half taper angle and is locked by the cutting rod is adjusted to a fixed position for the best possible to the open hand wheel and cross feed.
- Then the carriage is locked and first cut is made at the end of the cut, the tool is again cross fed is given for the next cut. Cuts are repeated piece is then removed from the chuck and dimensions obtained are noted.
- Finally the knurling operation is performed on the specified outer diameter with the aid of a knurling tool.

Precautions:

1. The work piece should be fixed tight in the jaw.
2. The power supply switched off before measuring diameters.

Result:

DRILLING AND BORING ON LATHE

EXP NO: 9

DATE :

Aim: To perform Drilling and Boring operation on the given cylindrical work piece.

Apparatus:

1. Lathe with standard accessories.
2. Steel rule, Vernier Callipers.
3. Work piece – Mild steel Round rod of 1 inch Dia.

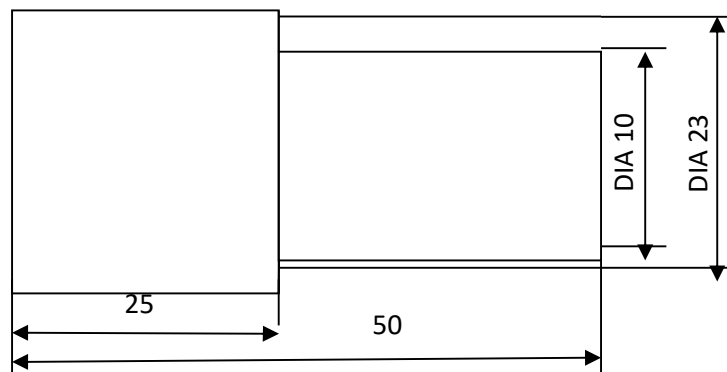

DIMENSIONS OF TAPER TURNING

Procedure:

- The work piece is fixed in the tool post tightly.
- The center of head stock and tail stock is coincided with the centers of head stock and tail stock.
- Facing and plain turning operations are performed to get the required diameter on the work piece.
- Drilling is performed on the job with the appropriate drill bit and required stock is maintained for the boring operation and
- Finally the Boring operation is performed on the specified diameter with the aid of a boring tool.

Precautions:

1. The work piece should be fixed tight in the jaw.
2. The power supply switched off before measuring diameters.

Result:

JOB ON GRINDING OF TOOL ANGLES

EXP NO: 10

DATE :

AIM: To perform Grinding of Tool Angles on the given specimen.

Apparatus:

1. Tool and cutter grinder
2. Vernier caliper
3. Work piece – 10 X 10 X 80 mm

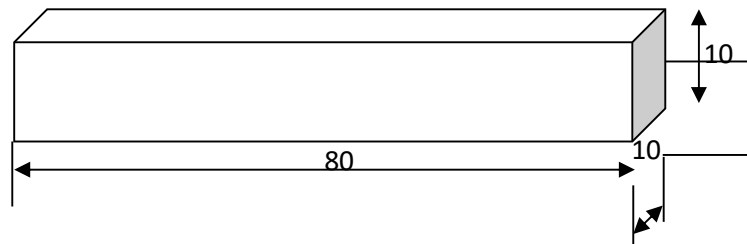

DIMENSIONS OF THE JOB

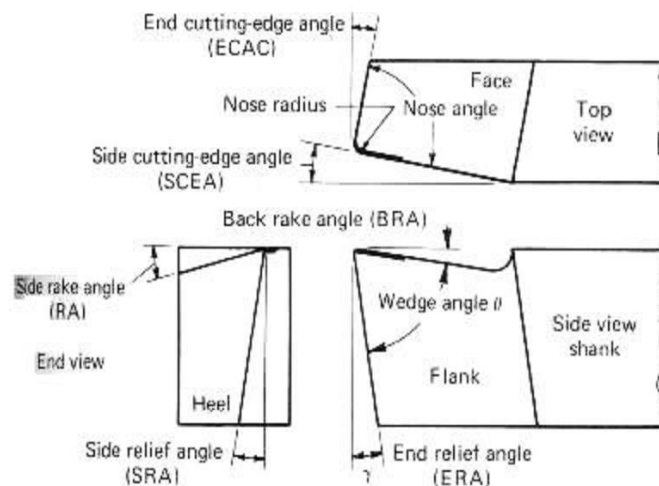

NOMICULATEOF SINGLE POINT CUTTING TOOL

1. Side Cutting Edge Angle:

The angle between side cutting edge and the side of the tool shank is called side cutting edge angle. It is often referred to as the lead angle.

2. End Cutting Edge Angle:

The angle between the end cutting edge and a line perpendicular to the shank of he tool shank is called end cutting edge angle.

3. Side Relief Angle:

The angle between the portion of the side flank immediately below the side cutting edge and a line perpendicular to the base of the tool.

4. End Relief Angle:

The angle between the end flank and the line perpendicular to the base of the tool is called end relief angle.

5. Back Rake Angle:

The angle between the face of the tool and line perpendicular to the base of the tool measures on perpendicular plane through the side cutting edge. It is the angle which measures the slope of the face of the tool from the nose, towards the rack. If the slope is downward the nose it is negative back rake.

6. Side Rake Angle:

The angle between the face of the tool and a line parallel to the base of the tool measured on plane perpendicular to the base and the side edge. It is the angles that measure the slope of the tool face from the cutting edge, if the slope is towards the cutting edge it is negative side rake angle and if the slope is away from the cutting edge, it is positive side rake angle. If there is no slope the side rake angle is zero.

PROCEDURE:

1. Check the work piece with a vernier caliper according to the dimensions as per required length, breadth and thickness.
2. The given work piece is fixed in the rotating vice provided on the machine table such a one end of it is projected outside the jaws of the vice.
3. A Grinding wheel Cutter is mounted on the machine spindle one end angle of the work piece is grinded according to the required angle, by indexing the Work piece to the required angle.
4. Repeat the same procedure to obtain all angles of single point cutting tool on the given work piece.

PRECAUTIONS:

1. The tool and cutter grinder must be stopped before setting up or removing a work piece, cutter or other accessory.
2. Wear the goggles for protection of eyes from the spark while grinding the angles.
3. Keep the work piece to the appropriate angle.

RESULT: