

MEASUREMENTS AND SENSORS LAB

III B.Tech-I SEMESTER

**LABORATORY
DEMONSTRATION**
ON
MEASUREMENTS AND SENSORS
(20A02503P)

By

D.chinna Dastagari

Assistant Professor

Department of EEE

VEMU IT ,CHITTOOR

VISION OF THE INSTITUTE

To be a premier institute for professional education producing dynamic and vibrant force of technocrat with competent skills, innovative ideas and leadership qualities to serve the society with ethical and benevolent approach.

MISSION OF THE INSTITUTE

Mission_1: To create a learning environment with state-of-the-art infrastructure, well equipped laboratories, research facilities and qualified senior faculty to impart high quality technical education.

Mission_2: To facilitate the learners to foster innovative ideas, inculcate competent research and consultancy skills through Industry-Institute Interaction.

Mission_3: To develop hard work, honesty, leadership qualities and sense of direction in rural youth by providing value based education.

VISION OF THE DEPARTMENT

To produce professionally deft and intellectually adept Electrical and Electronics Engineers and equip them with the latest technological skills, research & consultancy competencies along with social responsibility, ethics, Lifelong Learning and leadership qualities.

MISSION OF THE DEPARTMENT

Mission_1: To produce competent Electrical and Electronics Engineers with strong core knowledge, design experience & exposure to research by providing quality teaching and learning environment..

Mission_2: To train the students in emerging technologies through state - of - the art laboratories and thus bridge the gap between Industry and academia.

Mission_3: To inculcate learners with interpersonal skills, team work, social values, leadership qualities and professional ethics for a holistic engineering professional practice through value based education.

PROGRAMME EDUCATIONAL OBJECTIVES (PEOS)

PEO_1: Provide sound foundation in mathematics, science and engineering fundamentals to analyze, formulate and solve complex engineering problems.

PEO_2: Have multi-disciplinary Knowledge and innovative skills to design and develop Electrical & Electronics products and allied systems.

PEO_3: Acquire the latest technological skills and motivation to pursue higher studies leading to research.

PEO_4: Possess good communication skills, team spirit, ethics, modern tools usage and the life-long learning needed for a successful professional career.

- PO_1: Engineering knowledge:** Apply the knowledge of mathematics, science, engineering fundamentals, and an engineering specialization to the solution of complex engineering problems.
- PO_2: Problem analysis:** Identify, formulate, review research literature, and analyze complex engineering problems reaching substantiated conclusions using first principles of mathematics, natural sciences, and engineering sciences.
- PO_3: Design/development of solutions:** Design solutions for complex engineering problems and design system components or processes that meet the specified needs with appropriate consideration for the public health and safety, and the cultural, societal, and environmental considerations.
- PO_4: Conduct investigations of complex problems:** Use research-based knowledge and research methods including design of experiments, analysis and interpretation of data, and synthesis of the information to provide valid conclusions.
- PO_5: Modern tool usage:** Create, select, and apply appropriate techniques, resources, and modern engineering and IT tools including prediction and modeling to complex engineering activities with an understanding of the limitations.
- PO_6: The engineer and society:** Apply reasoning informed by the contextual knowledge to assess societal, health, safety, legal and cultural issues and the consequent responsibilities relevant to the professional engineering practice.
- PO_7: Environment and sustainability:** Understand the impact of the professional engineering solutions in societal and environmental contexts, and demonstrate the knowledge of, and need for sustainable development.
- PO_8: Ethics:** Apply ethical principles and commit to professional ethics and responsibilities and norms of the engineering practice.
- PO_9: Individual and team work:** Function effectively as an individual, and as a member or leader in diverse teams, and in multidisciplinary settings.
- PO_10: Communication:** Communicate effectively on complex engineering activities with the engineering community and with society at large, such as, being able to comprehend and write effective reports and design documentation, make effective presentations, and give and receive clear instructions.
- PO_11: Project management and finance:** Demonstrate knowledge and understanding of the engineering and management principles and apply these to one's own work, as a member and leader in a team, to manage projects and in multidisciplinary environments.
- PO_12: Life-long learning:** Recognize the need for, and have the preparation and ability to engage in independent and life-long learning in the broadest context of technological change.

PROGRAMME SPECIFIC OUTCOME(PSOS)

PSO_1: Higher Education: Apply the fundamental knowledge of Mathematics, Science, Electrical and Electronics Engineering to pursue higher education in the areas of Electrical Circuits, Electrical Machines, Electrical Drives, Power Electronics, Control Systems and Power Systems.

PSO_2: Employment: Get employed in Public/Private sectors by applying the knowledge in the domains of design and operation of Electronic Systems, Microprocessor based control systems, Power systems, Energy auditing etc.

LIST OF EXPERIMENTS

S.NO.	NAME OF THE EXPERIMENT
1	Calibration Of Single Phase Energy Meter
2	Calibration Of Dynamometer Type Power Factor Meter
3	Crompton D.C. Potentiometer Calibration Of PMMC Ammeter And PMMC Voltmeter
4	Kelvin's Double Bridge – Measurement Of Very Low Resistance Values Determination Of Tolerance
5	Measurement of % Ratio Error and Phase Angle of Given C.T. by Comparison
6	Schering Bridge & Anderson Bridge For Measurement Of Capacitance And Inductance Values

7	Measurement Of 3- Ph Reactive Power With Single Phase Wattmeter
8	Measurement of Parameters of a Choke Coil Using 3 Voltmeter and 3 Ammeter Methods
9	LVDT and Capacitance Pickup – Characteristics and Calibration
10	Resistance Strain Gauge – Strain Measurement and Calibration
11	Measurement of 3-\emptyset power using two – wattmeter method
12	Calibration of LPF wattmeter - by phantom testing

GENERAL INSTRUCTIONS FOR LABORATORY CLASSES

DO'S

1. Without Prior permission do not enter into the Laboratory.
2. While entering into the LAB students should wear their ID cards.
3. The Students should come with proper uniform.
4. Students should sign in the LOGIN REGISTER before entering into the laboratory.
5. Students should come with observation and record note book to the laboratory.
6. Students should maintain silence inside the laboratory.
7. Circuit connections must be checked by the lab-in charge before switching the supply

- **DONT'S**

1. Students bringing the bags inside the laboratory..
2. Students wearing slippers/shoes insides the laboratory.
3. Students scribbling on the desk and mishandling the chairs.
4. Students using mobile phones inside the laboratory.
5. Students making noise inside the laboratory.
6. Students mishandle the devices.
7. Students write anything on the devices

CALIBRATION OF SINGLE PHASE ENERGY METER

- **AIM:** To calibrate the Single Phase Energy Meter.

APPARATUS:

S.NO	ITEM NAME	RANGE
1	Single phase Energy Meter	300V/5-10A.
2	Digital Ammeter.	0-10A
3	Wattmeter.	300V/5A.
4	Digital Energy Meter.	80-270V AC / 50mA-6A
5	Digital Voltmeter.	0-300V.
6	I- ϕ Auto Transformer.	0-270V/5A

CIRCUIT DIAGRAM:

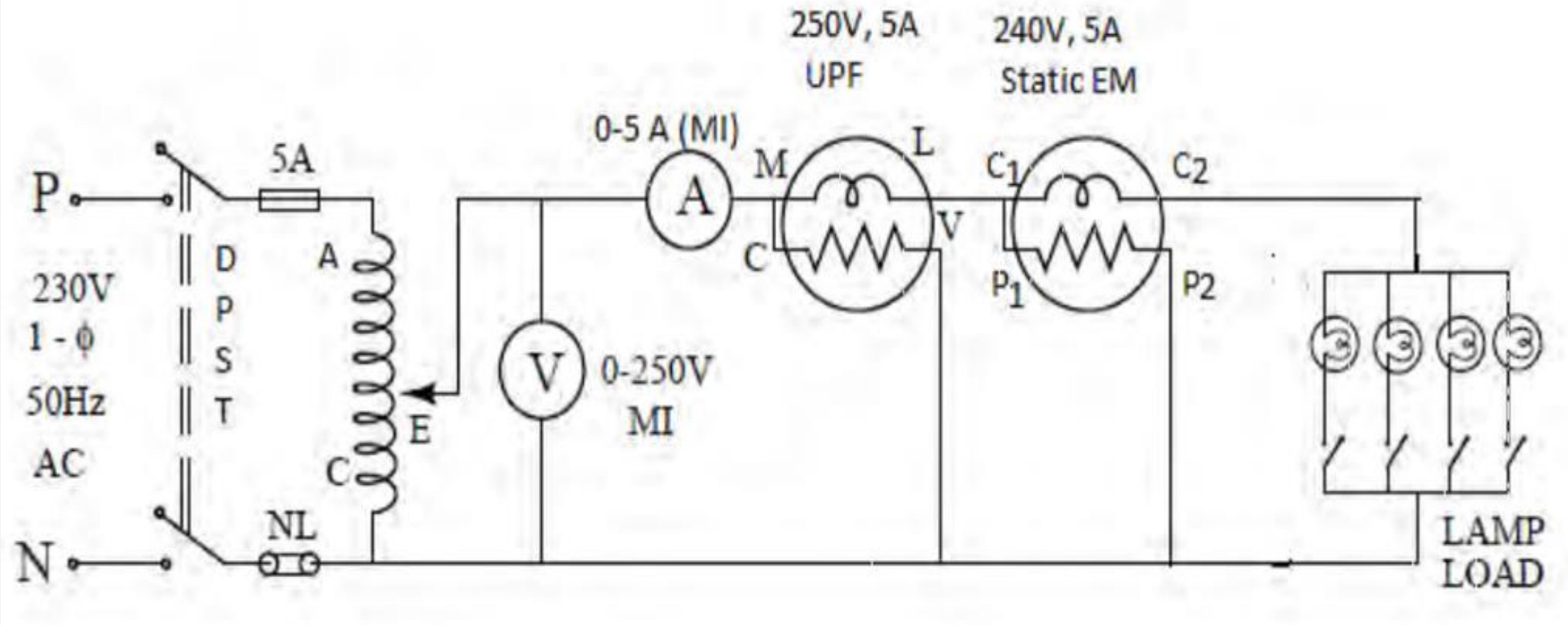

THEORY:

- The energy expended in a circuit in a known interval of time is measured with an energy meter to be calibrated .The rated voltage is applied across the voltage coil ,a small current is passed through the current coil .The disk rotates ,the time required for a definite number of rotations is noted .The standard wattmeter reading is noted . This is true power in the circuit.
 - **The indicated power is computed as follow ws,**
- Let K =Energy meter constant in revolutions/Kwh.
- We have indicated power $W_i = K' R/t$. where $K' = 1000 \times 3600 / K$ and a unit of $K' =$ watt.
 - **Actual power $W_A =$ wattmeter reading,**
- If W_a and W_i are the same there is no error .If however, W_i is not equal to W_a it implies that there is error.
 - **We have percentage error = $(W_i - W_a) / W_a \times 100$,**
- The percentage error may be positive or negative .the experiment is conducted by passing deferent currents, starting from 5% of full load and increasing in steps till full load is reached.

PROCEDURE:

1. Make connections as per circuit diagram.
2. Keep auto transformer at zero position and switch ON MCB.
3. Switch ON supply by pressing green switch
4. Adjust the auto transformer such that voltmeter reads at rated voltage i.e.230V.
5. Low load adjustment:- Adjust 10% of rated current to flow through energy meter by varying the load
6. Note down the time taken by disc to rotate known number of revolutions using stop watch.
7. Calculate time taken theoretically.
8. Top Load adjustment:-90% of rated current is (8-9) A is made to flow.
9. Note down the time taken by disc to rotate known number of revolutions (say5) using stop watch.
10. Calculate time taken theoretically.
11. Repeat the same procedure for deferent values.

CALCULATIONS:

- Actual Energy Consumed = $P * t / 60 * 60$
- Where 'P' is Power in Watts and 'T' is in seconds.
- Energy Recorded = No. of Revolutions / [Revolutions per Kilo watt]

VIVA QUESTIONS

1. What are the different torques existing in energy meter?
2. What is the use of braking magnet?
3. What are the different possible errors in the energy meter?
4. How the energy meter constant is expressed?
5. What is phantom loading?
6. How do you compensate the frictional error?

CALIBRATION OF DYNAMOMETER TYPE POWER FACTOR METER

AIM:

To test and calibrate the given 3 phase electro dynamometer type power Factor meter.

APPRATUS:

S. No	Item Name	Specifications	Quantity
1	Dynamometer Power Factor meter	I-Ph, 10A, 300V	1
2	Ammeter	0-10A, MI	1
3	Wattmeter	0-10A, 300V, UPF	1
4	Voltmeter	0-300V, MI	1
5	Capacitive Load	I-Ph, 10A, 300V	1
6	Connecting Wires	-----	As per Required

CIRCUIT DIAGRAM:

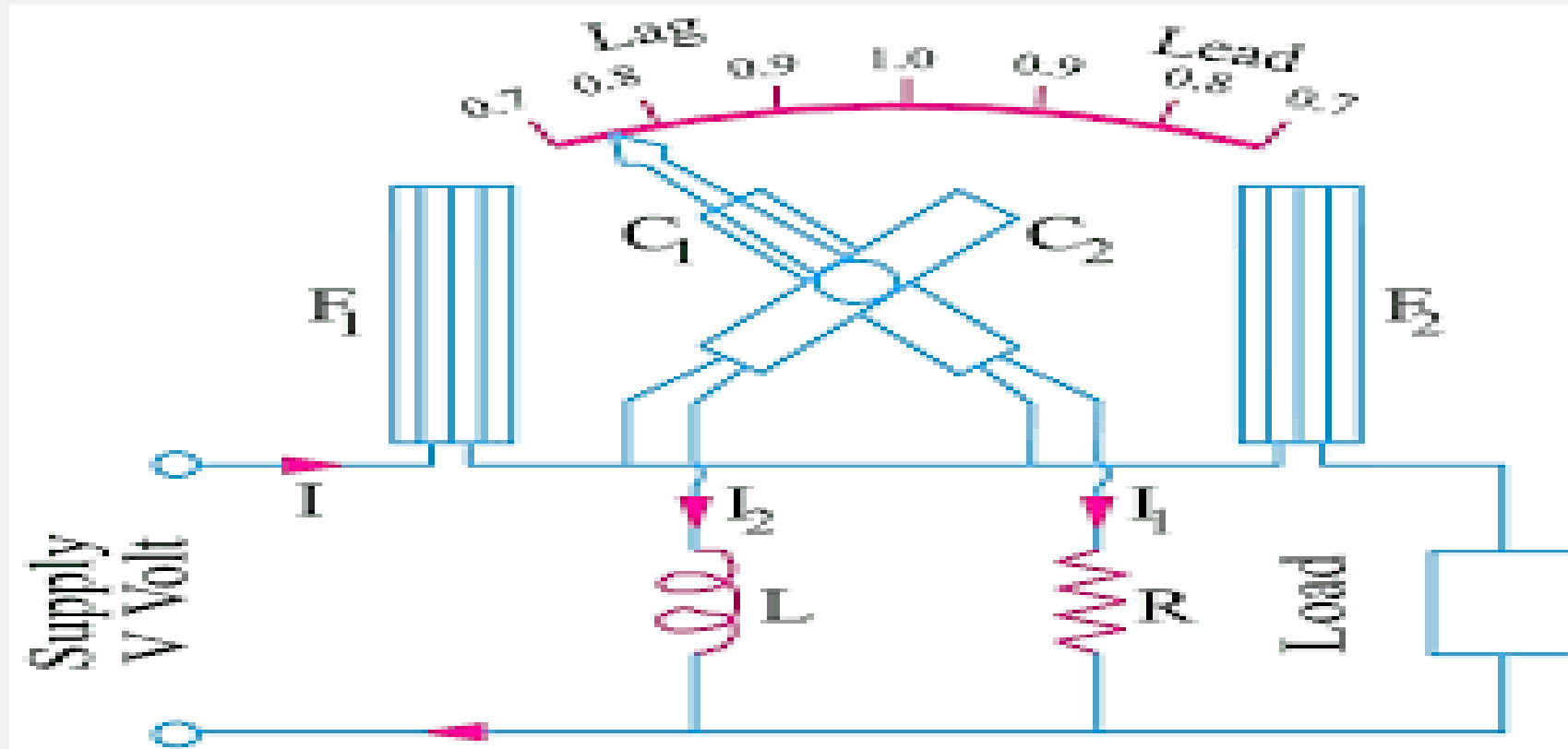

PROCEDURE:

1. Connect the circuit as per circuit diagram.
2. Start the motor using starter.
3. Load the motor in steps from low power factor to meet unity power factor (from no load to full load).
4. Observe all the meter readings in each step.
5. Calculate the power factor at each from the power factor meter and from the wattmeter and voltmeter and ammeter.
6. Remove the load and switch of the supply.
7. Graph is plotted between %error and calculated values.

FORMULAE:

- %Error = [(True Value – Measured Value)/Measured Value] * 100
- **True Value $\cos \phi = W / VI$**

CROMPTON D.C. POTENTIOMETER – CALIBRATION OF PMMC AMMETER AND PMMC VOLTMETER

AIM: Standardization of DC potentiometer and measuring of unknown emf's.

APPARATUS:

S.NO	ITEM NAME	RANGE
1	Standard cell	1.0180V
2	Battery	DC.2V
3	Galvanometer	100-0-100 or 50- 0- 50 range

CIRCUIT DIAGRAM:

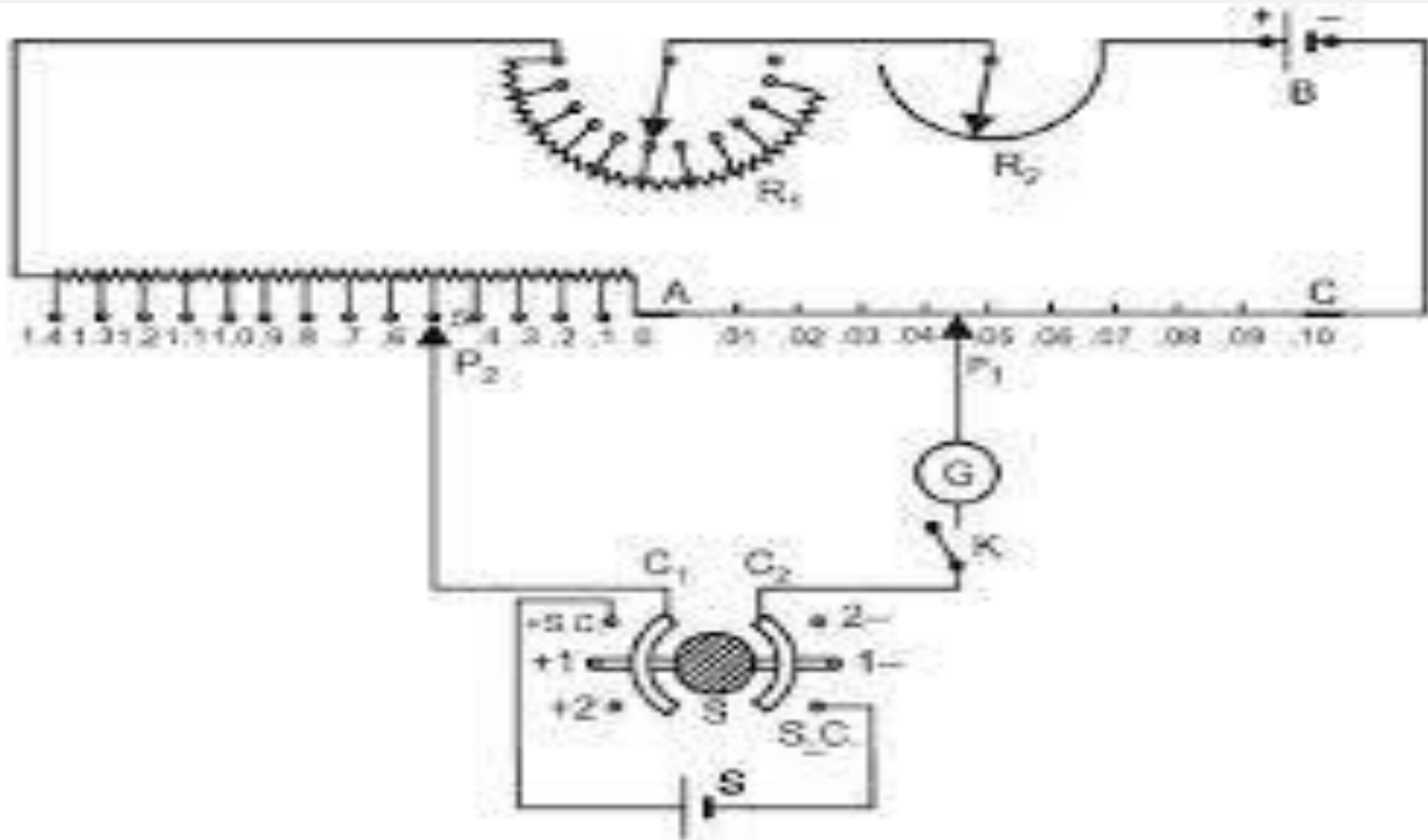

THEORY:

- Potentiometer is an instrument for measuring an unknown emf or potential difference by balancing it wholly or in part by a known potential difference produced by the flow of current in network of a ckt of known character electromotive forces are measured directly with a potentiometer in terms of emf of a standard cell. By using in addition a standard resistance current can also be measured from potentiometer measurement of current and voltage. Power can be calculated and if time is also measured energy can be calculated.

PROCEDURE:

1. Give the connections as per the terminals indicated in the potentiometer with Reference the polarity (connect the galvanometer standard cell and battery to their).
 2. Initially for Standardize the potentiometer for a given standard cell voltage i.e., set the potential dials to exact volt. of standard cell,(Function key in STD mode
 3. (ie,1.018v, 1 volt at Main Dial ,18 Mill Volts at Slide Dial & keep constant) by varying the Rheostat course and fine Rheostat .
 4. When the Galva key pressed, the Galvanometer should not deflection with slide wire key pressed and zero series resistance then the potentiometer has been standardize for use.
 5. In the above case maintain the sensitivity of Galvanometer from low range to high range, Shunt Power Switch (SC, 1/1000, 1/100, 1/10, 1) which is kept aside of the Galvanometer by, Keep the toggle switch in AC Mains.
- At the top of the Galvanometer the pointer is to be kept in free position when functioning, and in lock position when it is not functioning

MEASURING THE UNKNOWN VOLTAGE(EMF):

1. Connect the supply to be measured to appropriate terminals on the potentiometer by Maintain the polarity, (Function key in STD mode
2. Turn the Function key from STD mode E1 or E2, which is the unknown emf's Connection.
3. By keeping the Rheostat Constant, vary the Main Dial as well as Slider Dial until get The reading null point zeros in the galvanometer.
4. In the above case maintain the sensitivity of Galvanometer from low range to high Range, Shunt Power Switch (SC, 1/1000, 1/100, 1/10, 1) which is kept aside of the Galvanometer by, Keep the toggle switch in AC Mains.
5. Standardized the potentiometer and measure the unknown voltage.

PRECAUTIONS:

1. A variable high resistance should be connected in series with the galvanometer to protect the galvanometer and standard cell for initial adjustment.
2. Connections should always be marked with due care of polarity.
3. Precautions for standard cell should be strictly observed.
4. Standardize the potentiometer at intervals during prolonged test to compensate for any slight drift in the battery voltage

KELVIN'S DOUBLE BRIDGE – MEASUREMENT OF VERY LOW RESISTANCE VALUES DETERMINATION OF TOLERANCE

- **AIM:** To determine the unknown resistance that is low resistance between 0.2 to 11 Ω .
- **APPARATUS:**

S.NO	ITEM NAME
1	DC supply
2	Unknown resistance
3	Galvanometer
4	Kelvin's double bridge consisting of <ol style="list-style-type: none">1. Main dial2. Slide wire3. Range switch

CIRCUIT DIAGRAM

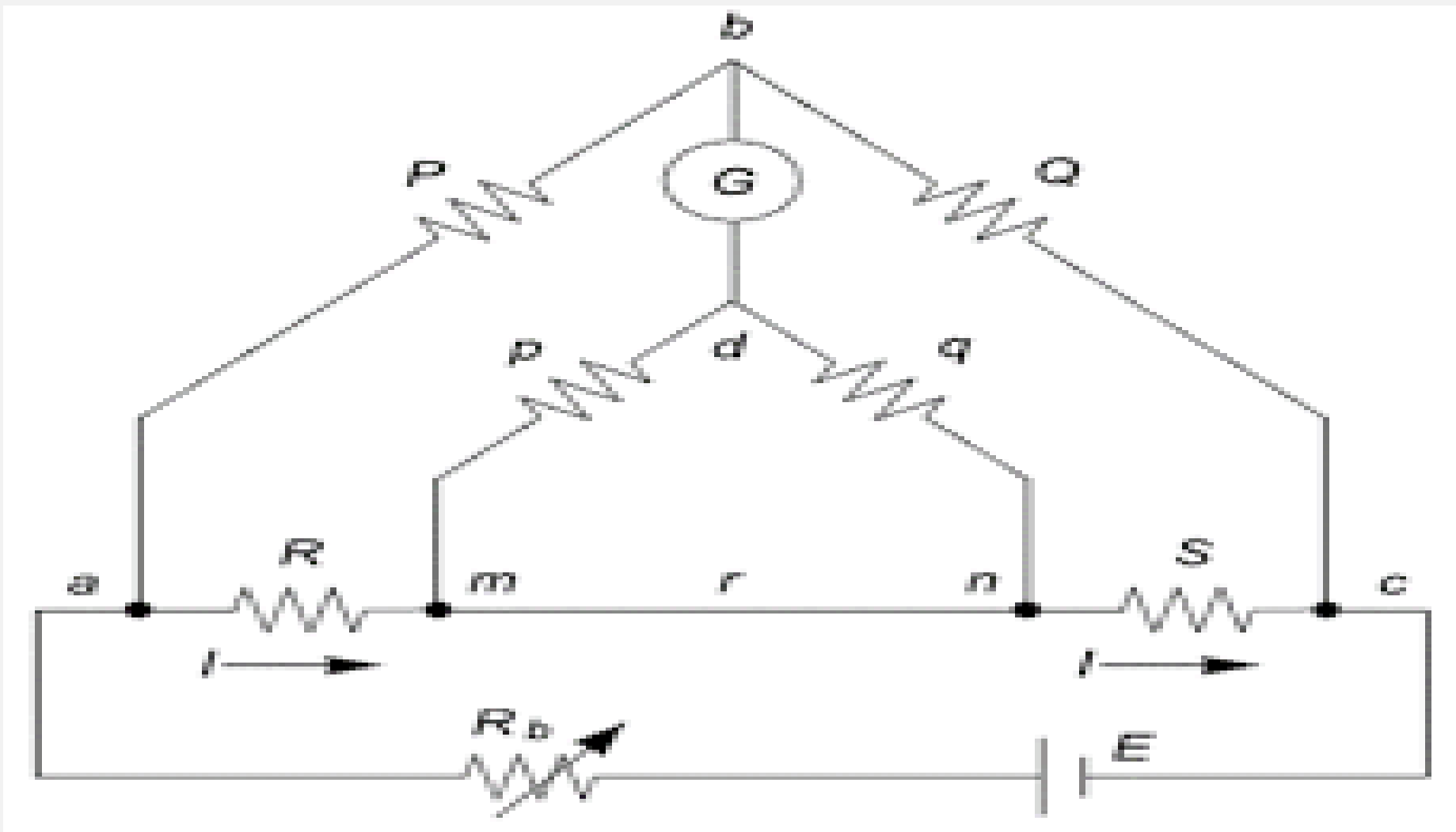

THEORY

The bridge is suitable for measurement of low resistances in the range 0.2Ω to 11Ω . Main dial: there are 10 coils of 0.01Ω or $10 \text{ m} \Omega$ each arranged on the dial. Slide wire: 100 divisions of slide wire are equal to 0.01Ω or $10 \text{ m} \Omega$ each main division is equal to 0.00002Ω or $0.02 \text{ m} \Omega$. The reading to the left zero is to be subtracted from the main dial reading and that to be right of zero is to be added to the main dial reading. Range switch: a range multiplier switch finishes multiplying ratio of $\times 100$, $\times 1$, $\times 0.1$ and $\times 0.01$.

The value of unknown resistance is given by sum of main dial and slide wire reading multiplied by range used the choice of which depends upon the magnitude of unknown resistance. The spot reflecting galvanometer of low resistance is recommended to be connected to terminals. Marked GALVONMETER on the bridge. It operates on 220V AC mains. The coil is set free by turning the pointed knob in the free position. The spot of light is set in the center of scale by using the zero adjuster.

PROCEDURE

1. Set the galvanometer to null position.
2. Connect the unknown resistance at given terminals.
3. Set the current switch.
4. Adjust main dial and slide wire and get null point in galvanometer.
5. The sum of main dial and slide wire multiplied by range used gives the valued of unknown resistance.

CALCULATIONS:

Unknown resistance = range (main dial + slide wire)

PRECAUTIONS:

1. While connection +p and –p on bridge to unknown resistance only the potential lead supplied with bridge should be used.
2. Only that portion of resistance is measured which is enclosed between potential points.
3. Avoid continuous flow of current in the bridge. Instead pass current for short while away.
4. The potentiometer for consisting the current of DC source is 1K – 3W wire wound and is easily replicable if it is given some trouble.

VIVA QUESTIONS

- 1) What is a four terminal resistance?
- 2) Why we have to take readings in normal and reverse directions?
- 3) What is the measurement range of Kelvin double bridge?
- 4) What is the accuracy of Kelvin double bridge?
- 5) What is its advantage over Wheatstone bridge?
- 6) Why high current source is preferred in this method?

MEASUREMENT OF % RATIO ERROR AND PHASE ANGLE OF GIVEN C.T. BY COMPARISON

AIM: To measure the % ratio error and phase angle of given CT.

- **APPARATUS:**

S.NO	ITEM NAME
1	Precision CT
2	Commercial CT
3	Watt meters (LPF)
4	Rheostat
5	Phase shifting Transformer

CIRCUIT DIAGRAM:

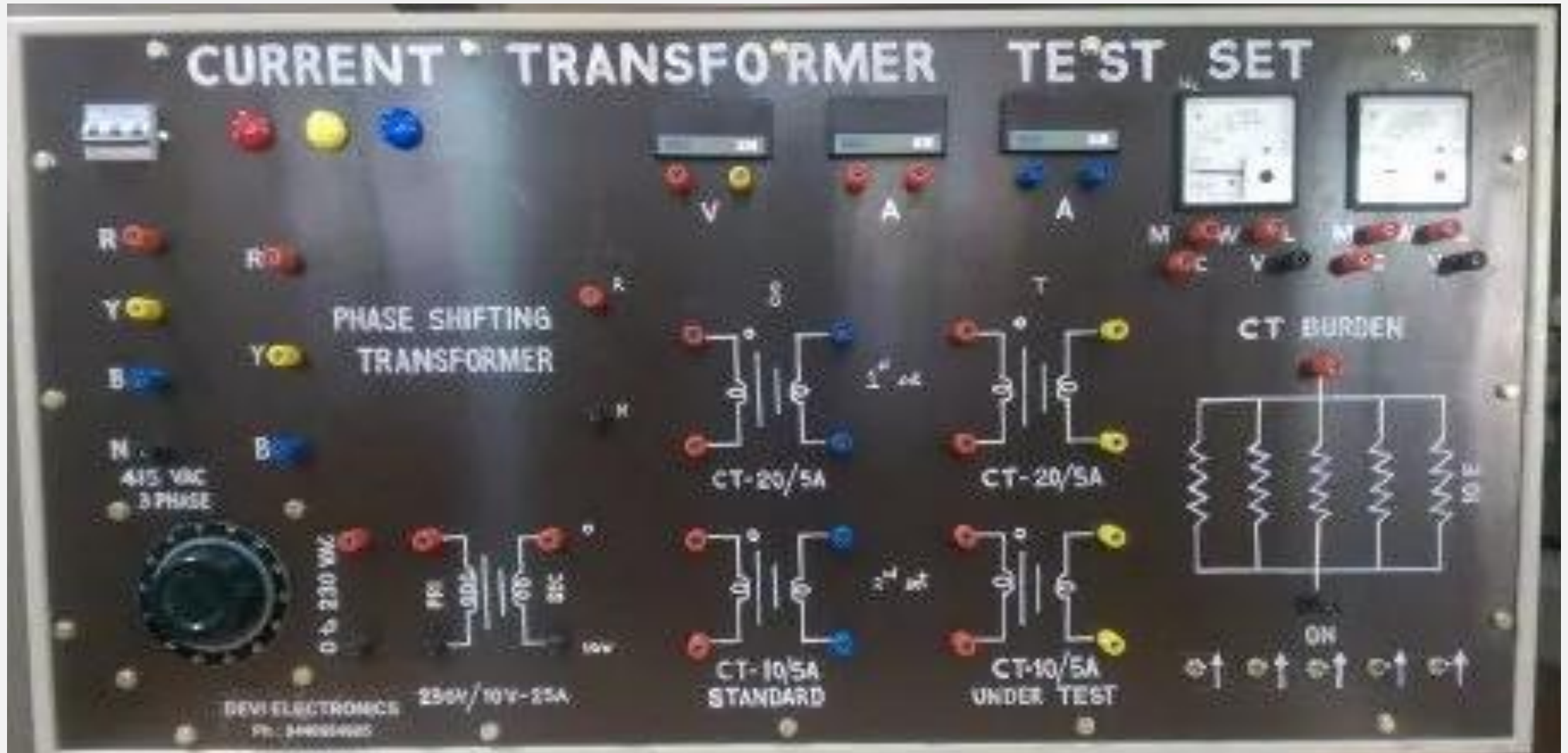

PROCEDURE:

1. Connections are made as shown.
2. The Supply switch to the autotransformer is closed with the rheostat cut out.
3. The current through the CT primaries is gradually increased using autotransformer.
4. The current I_D , difference between I_{SS} & I_{SX} , should be zero.
5. If it is twice that of I_{SS} or I_{SX} , the supply switch is opened and connections to any one of the CT secondary's are reversed
6. The current I_P through the CT primaries is made equal to a fixed value using autotransformer.
7. The burden in the form of Rheostat is introduced in the secondary circuit of the CT to be compared. And is slowly cut in till I_D is equal to fixed value.

1. Wattmeter WS is made to indicate zero using phase shifter.
2. Readings of Ammeter and Wattmeter WD2 are noted.
3. WS is adjusted to indicate maximum reading by means of Phase shifter and the reading of the Ammeters and Wattmeter WD1 are noted.
4. Voltage applied to wattmeter potential coils is also noted.
5. This procedure is repeated for different primary currents like 15 A & 20 A.
6. The readings and results are tabulated as shown.

SCHERING BRIDGE & ANDERSON BRIDGE FOR MEASUREMENT OF CAPACITANCE AND INDUCTANCE VALUES

AIM: To determine the unknown capacitance using Schering Bridge.

APPARATUS

S.NO	ITEM NAME
1	KHz frequency oscillator Digital millimeter.
2	3 unmarked capacitors of different values
3	4 decade resistances, 2 in 100E steps & 2 in 10E steps,
4	2 decade capacitors in 0.0001 MFD step
5	1 potentiometer of 10K Ohm range

CIRCUIT DIAGRAM

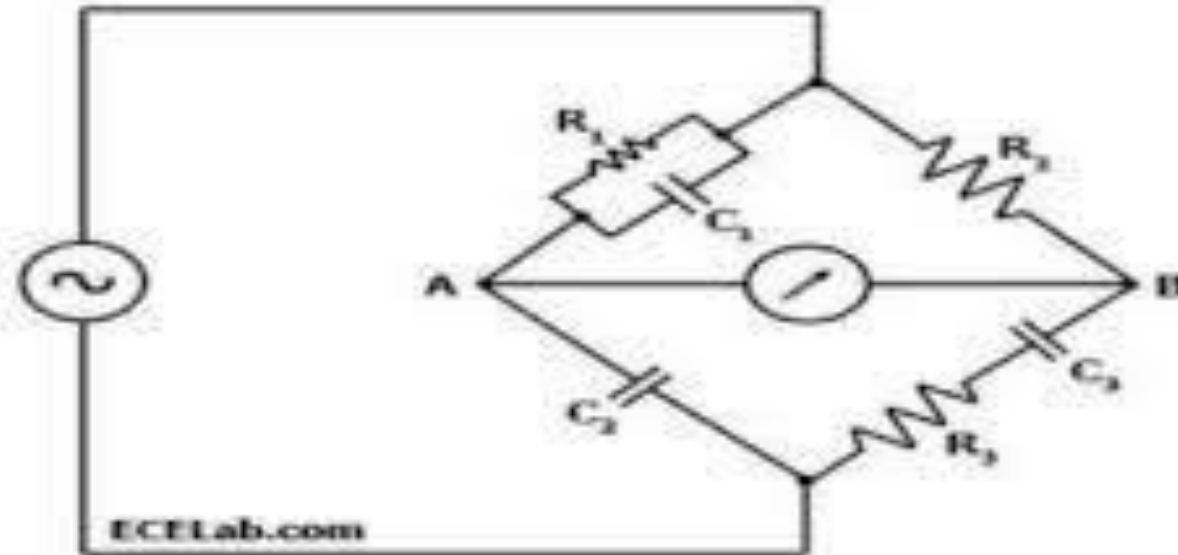

Figure Schering Bridge

THEORY

Schering Bridge is widely used for capacitance a dissipation factor measurement. Infact Schering Bridge is one of the most important of AC bridges. It is extensively used in the measurement of capacitance in general and in particular in the measurement of the properties of insulators, capacitor bushings insulating oil and other insulation material.

Let C_1 = capacitance whose capacitance is to be measured.

R_1 = a series resistance representing the loss in capacitor 'C'

C_2 = a standard capacitor, this capacitor is either an air core or gas capacitor and hence is loss free.

However if necessary a connection may be made for the loss

angle of capacitor. R_3 = a non – inductive resistance

C_4 = a variable capacitor

R_4 = a variable non-inductive resistance in parallel with variable capacitor C_4 . At balance

$$(r_1 + R_4 / j\omega C_1)(R_4 / 1+j\omega C_4R_4) = (1 / j\omega C_2)$$

$$R_3 (r_1 + 1 / j\omega C_1) R_4 = (R_3 / j\omega C_2) (1+j\omega$$

$$C_4R_4) r_1 R_4 - j R_4/ \omega C_1 = j R_3/ \omega C_2+ R_3 R_4$$

$$C_4 / C_2$$

Equation real and imaginary terms.

PROCEDURE

1. Using patch cards make connection as per Circuit diagram.
2. Connect fixed frequency Oscillator at point P- R and digital multimeter at Q & S.
3. Keep level control of oscillator at max.level.
4. Take C2 of a suitable value.
5. Keep C1 at 0.0001 MFD.
6. Adjust R1, R2, R3 till we get min reading in multimeter.

Record the values

(B) ANDERSON BRIDGE

- **AIM:** To determine the self inductance by using Anderson's Bridge.
- **APPARATUS:**

S.NO	ITEM NAME
1	Frequency oscillator – 1000 cps
2	10V variable supply
3	Head phones
4	Anderson's bridge
5	P– Non-inductive resistance Q- Non-inductive resistance R- Non-inductive resistance

CIRCUIT DIAGRAM:

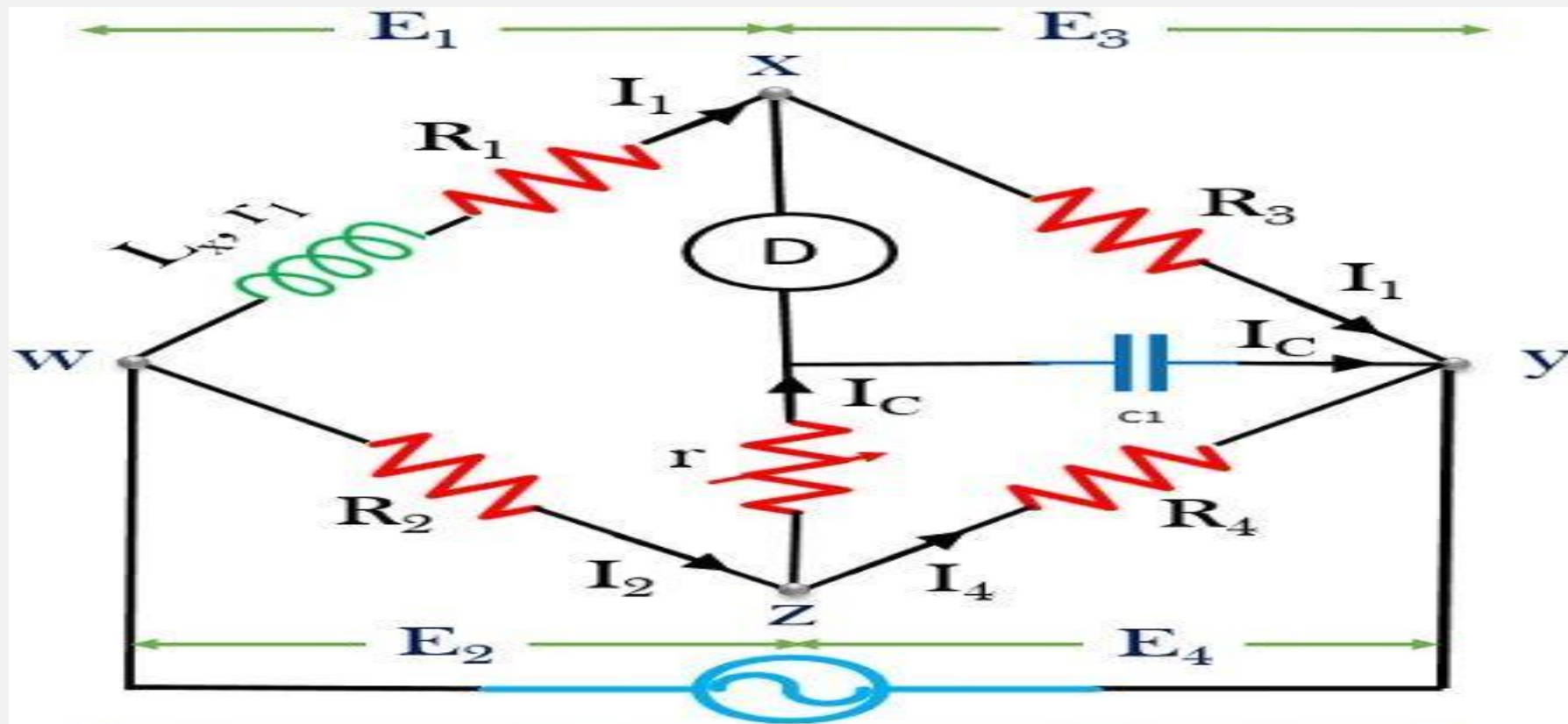

Anderson's Bridge

THEORY

- In this self inductance is measured in terms of a standard capacitor. This method is applicable for precise measurement of self inductance over a very wide range of values. The circuit shown in the next page shows the connections and phase diagram of bridge for balance conditions.
- Let L_1 = self inductance to be measured
 - R_1 = resistance connected in series with self inductance. R_1, R_2, R_3, R_4 = known non-inductive resistances
 - C = fixed standard capacitor
- At balance, $I_1 = I_3$ & $I_2 = I_c + I_4$
 $I_1 R_3 = I_c (1/j\omega C)$
- Therefore, $I_c = I_1 j\omega C R_3$
 $I_1 (r_1 + R_1 + j\omega L_1) = I_2 R_2 + I_c r$
 $I_1 (r + 1/j\omega C) = (I_2 - I_c) R_4$

➤ Sub the value of I_c

- $I_1 (r_1 + R_1 + j\omega L_1) = I_2 R_2 + I_1 j\omega C R_3 r$

$$I_1 (r_1 + R_1 + j\omega L_1 - j\omega C R_3 r) = I_2 R_2$$

- $j\omega C R_3 I_1 (r_1 + 1/j\omega C) = [(I_2 - I_1) j\omega C] R_4$

➤ Equating real and imaginary parts, $R_1 =$

$$R_2 R_3 / R_4 - r_1$$

- $L_1 = C R_3 / R_4 [r (R_4 + R_2) + R_2 R_4]$

- This bridge may be used for accurate determination of capacitance in terms of inductance.

PROCEDURE

1. Connect oscillator and head phones to proper terminals.
2. Vary S & M alternatively change C to suitable value of R.
3. Adjust until the pointer is at null position.
4. Record the values, $L = C (PQ + (R + S) M)$

PRECAUTIONS

1. Value of C should be small so as to allow sufficient variation of M .
2. In all calculations, value of S should include resistance of self inductance.
3. Only minimum sound should be heard.
4. The AC balance should be obtained by varying S and M alternatively.

VIVA QUESTIONS

- **SCHERING BRIDGE:**

1. What is a stray capacitance? Is it possible to eliminate it?
2. What is the effect of stray capacitance on the accuracy of measurement?
3. Why Schering Bridge is more convenient for measuring capacitance and loss factor when compared and loss factor when compared to the other methods?
4. What is Wagner's earthing device and its purpose?

- **ANDERSON BRIDGE:**

1. What problems have you come across during balance?
2. What is the accuracy of the bridge when compared to other methods?
3. What is the order of 'Q' factor of the unknown inductance that is suitable for measurement?
4. Compare its performance with Maxwell's bridge?

MEASUREMENT OF 3- PHASE REACTIVE POWER WITH SINGLE PHASE WATTMETER

- **AIM:** To measure the total reactive power of a three phase balanced load using a single phase wattmeter.
- **APPARATUS:**

S.NO	ITEM NAME	SOECIFICATIONS	QUANTITY
1	Wattmeter	(0- 10 A/ 600V)	2Nos
2	Ammeter	(0- 5A AC)	1 No
3	Voltmeter	(0 – 600 V AC)	1 No
4	Wattmeter	(0-10A/600V, LPF)	-
5	Connecting Wires	---	---

CIRCUIT DIAGRAM

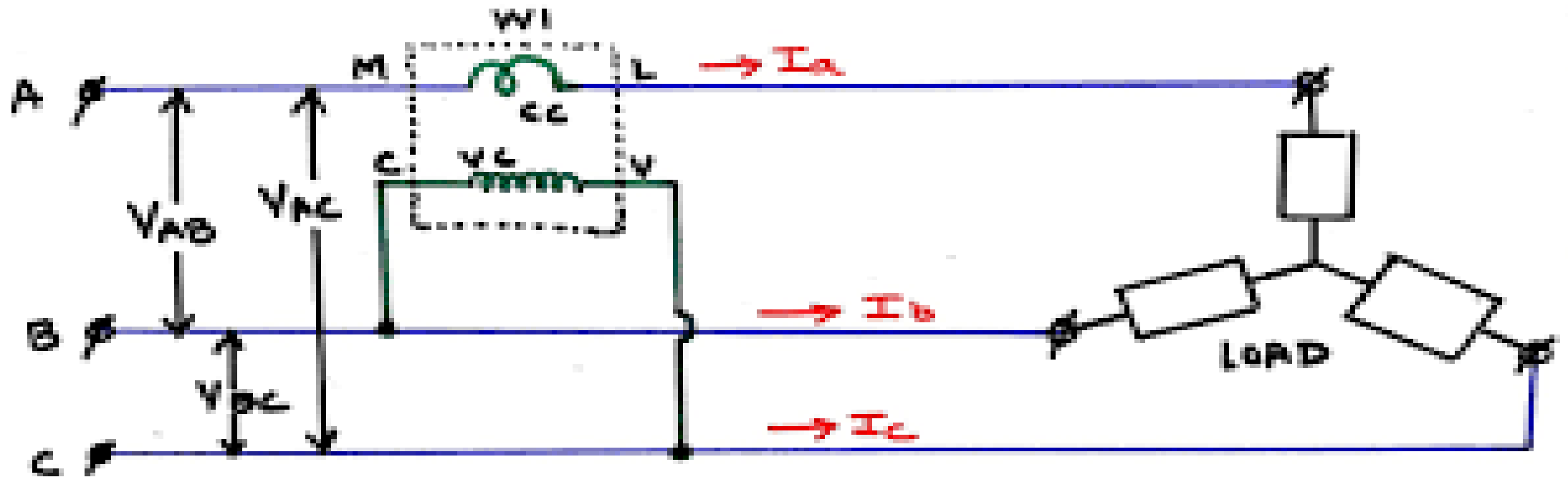

WI = WATTMETER
CC = CURRENT COIL
VC = VOLTAGE COIL

PROCEDURE

1. Connections are made as per circuit diagram.
2. The Autotransformer is in minimum output position.
3. The inductive load should be kept in fully closed position (Maximum reactance position).
4. Switch on the supply, by slowly varying the autotransformer, rated value is applied to motor.
5. Observe the meter readings if wattmeter reads negative change the CC connections.
6. Vary the reactance of the load by moving the knob in open direction,.
7. Ammeter, Voltmeter, Wattmeter readings are noted in each step by varying the load.
8. Close the load and switch of the supply.

MEASUREMENT OF PARAMETERS OF A CHOKE COIL USING 3 VOLTMETER AND 3 AMMETER METHODS

- 8(A).MEASUREMENT OF PARAMETERS OF A CHOKE COIL USING 3-VOLTMETER METHODS

- AIM: Measurement of Power consumed Power factor and Inductance of a Choke by 3-voltmeter.

- APPARATUS:

S.NO	ITEM NAME	SPECIFICATION	QUANTITY
1	Auto transformer	230/0-270V - 10amps	1 No
2	Voltmeter	0-300V AC	3 No
3	Ammeter	0-2 A AC	3 No
4	Load chokes	-	1 No

CIRCUIT DIAGRAM

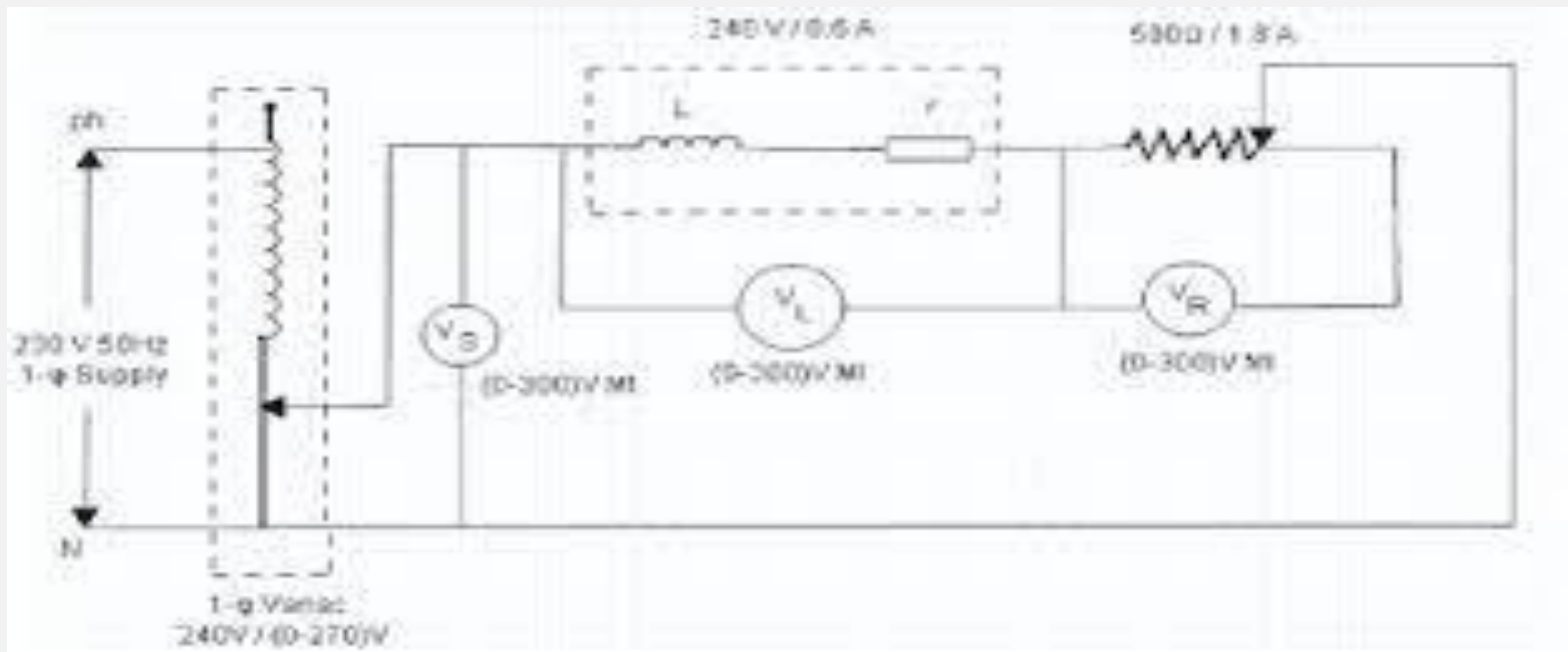

THEORY

- Power consumed in any circuit can be measured without a voltmeter by using either with 3 voltmeter.
 - Three voltmeter method: In this method 3 voltmeters and a known non inductive resistance is used. This resistance is connected in series with the load. As shown in the circuit one voltmeter is used in the experiment to measure the supply V_1 , voltage v_2 across the resistance and voltage V_3 across the load (choke).

- As per the phase diagram,

- $V_1^2 = V_2^2 + V_3^2 + 2 V_2 V_3 \cos \Phi_{PL} = V I_3 \cos$

$$\Phi = I_3^2 R_L$$

- Where $R =$ resistance of the choke $Z_L = V / I_3$

where $X_L = \sqrt{Z_L^2 - R_L^2}$ Therefore $L = X_L / 2\pi$

- As per the phase diagram,
- $I_{12} = \sqrt{I_2^2 + I_3^2 + 2 I_2 I_3 \cos \Phi}$
- Power factor, $\cos \Phi = \frac{I_1^2 - I_2^2 - I_3^2}{2 I_2 I_3}$
- Power consumed in the load $P_L = V I_3 \cos \Phi$, where $V = I_2 R$
 - $P_L = I_2 R I_3 (I_{12}^2 - I_2^2 - I_3^2) / 2 I_2 I_3$
- Power consumed in the load, $P_L = ((I_{12}^2 - I_2^2 - I_3^2) R) / 2$,
 - $\cos \Phi = \frac{V_{12}^2 - V_2^2 - V_3^2}{2 V_2 V_3}$
 - $P_L = V_3 I \cos \Phi$, $I = V_2 / R$ ($V_2 = I R$),
 - $P_L = V_2 V_3 / R (V_{12}^2 - V_2^2 - V_3^2) / 2 V_2 V_3$
 - Therefore $P_L = (V_{12}^2 - V_2^2 - V_3^2) / 2 R$

PROCEDURE:

- **Three Voltmeter method:**

1. Connect the circuit as shown in the circuit diagram.
2. Set the auto transformer at the zero position and switch ON the supply.
3. Increase input supply and note down V1, V2 and V3.
4. Tabulate the values as given in the table.
5. Switch OFF the supply.

- **Calculations for Three Voltmeter method**

- $V_{12} = V_{22} + V_{32} + 2 V_2 V_3 \cos \Phi$

$$\cos \Phi = \frac{V_{12} - V_{22} - V_{32}}{2 V_2 V_3}$$

8(B) MEASUREMENT OF PARAMETERS OF A CHOKE COIL USING 3-AMMETER METHODS

- **AIM:** Measurement of Power consumed Power factor and Inductance of a Choke by 3-Ammeter method.
- **APPARATUS**

S.NO	ITEM NAME	SPECIFICATION	QUANTITY
1	Auto transformer	0-270 V - 2amps	1 No
2	Voltmeter	0-300 V AC	3 No
3	Ammeter	0-2 A AC	3 No
4	Load chokes	-	1 No

CIRCUIT DIAGRAM

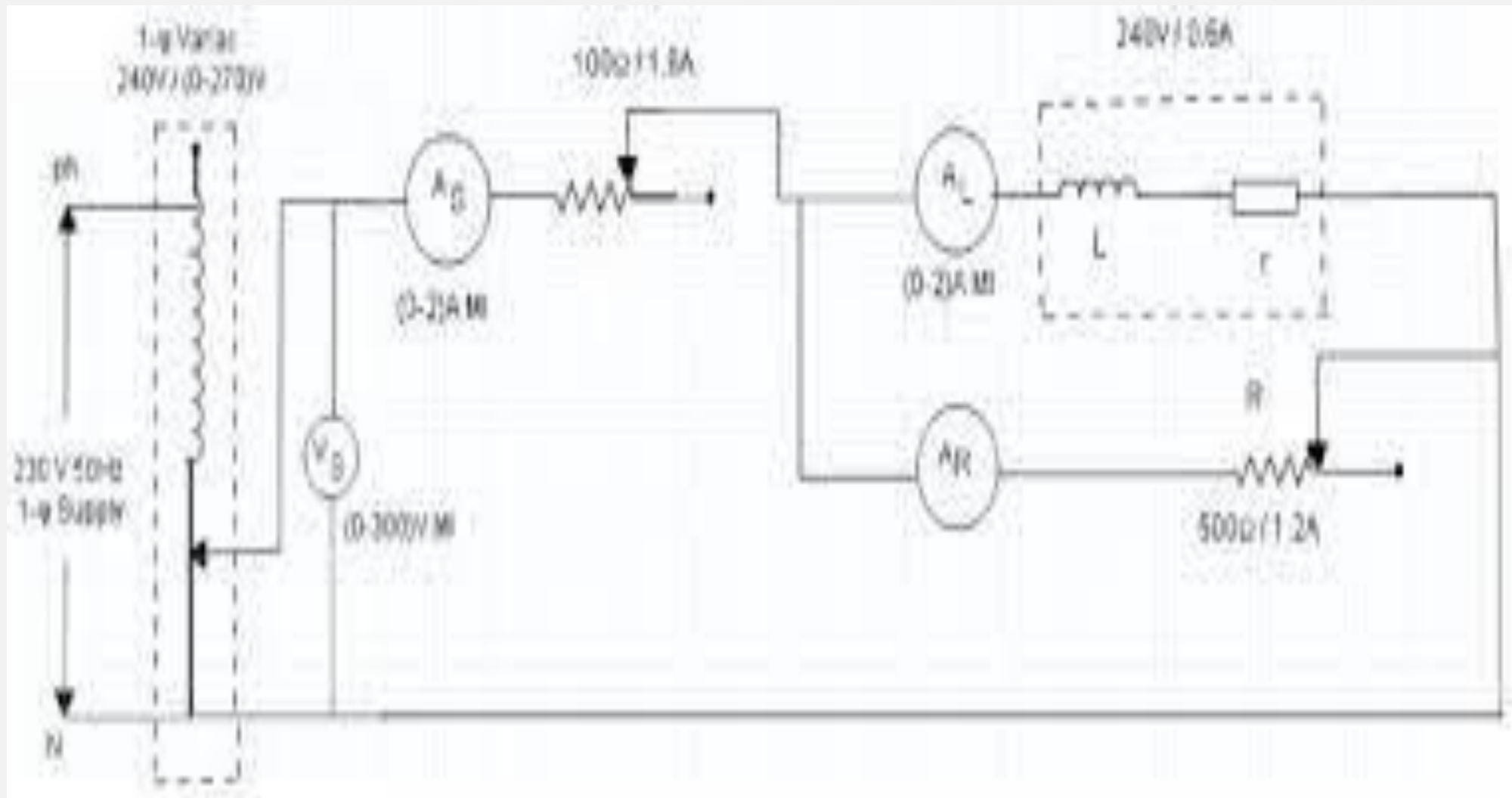

THEORY

- Power consumed in any circuit can be measured without a voltmeter by using either with 3 ammeters.
 - Three Ammeter method: In this method three ammeters are used, known resistance is connected in parallel to load. Where as in this experiment 1 ammeter and 3 no's of ON/OFF toggles switches are used to measure:
 1. Current drawn from the supply I_1
 2. Current through the resistance I_2
 3. Current through the load I_3

PROCEDURE

- **Three Ammeter method:**

1. Connect the circuit as shown in the circuit diagram.
2. Set the auto transformer at the zero position and switch ON the supply.
3. Increase input supply and note down I_1 , I_2 and I_3 .
4. Tabulate the values as given in the table.
5. Switch OFF the supply.

VIVA QUESTIONS

- Measurement of Parameters of Choke Coil Using 3 –Ammeters:-
 - 1) What are the various sources of errors in this method?
 - 2) What are the advantages and disadvantages of this method?
 - 3) Why this method is not generally preferred in the laboratory for measuring power in single Phase circuit?

LVDT AND CAPACITANCE PICKUP – CHARACTERISTICS AND CALIBRATION

AIM: To measure displacement using linear variable differential Transformer.

APPARATUS:

S.NO	ITEM NAME
1	LVDT
2	CRO
3	FUNCTION GENERATOR
4	CONNECTING WIRES

CIRCUIT DIAGRAM

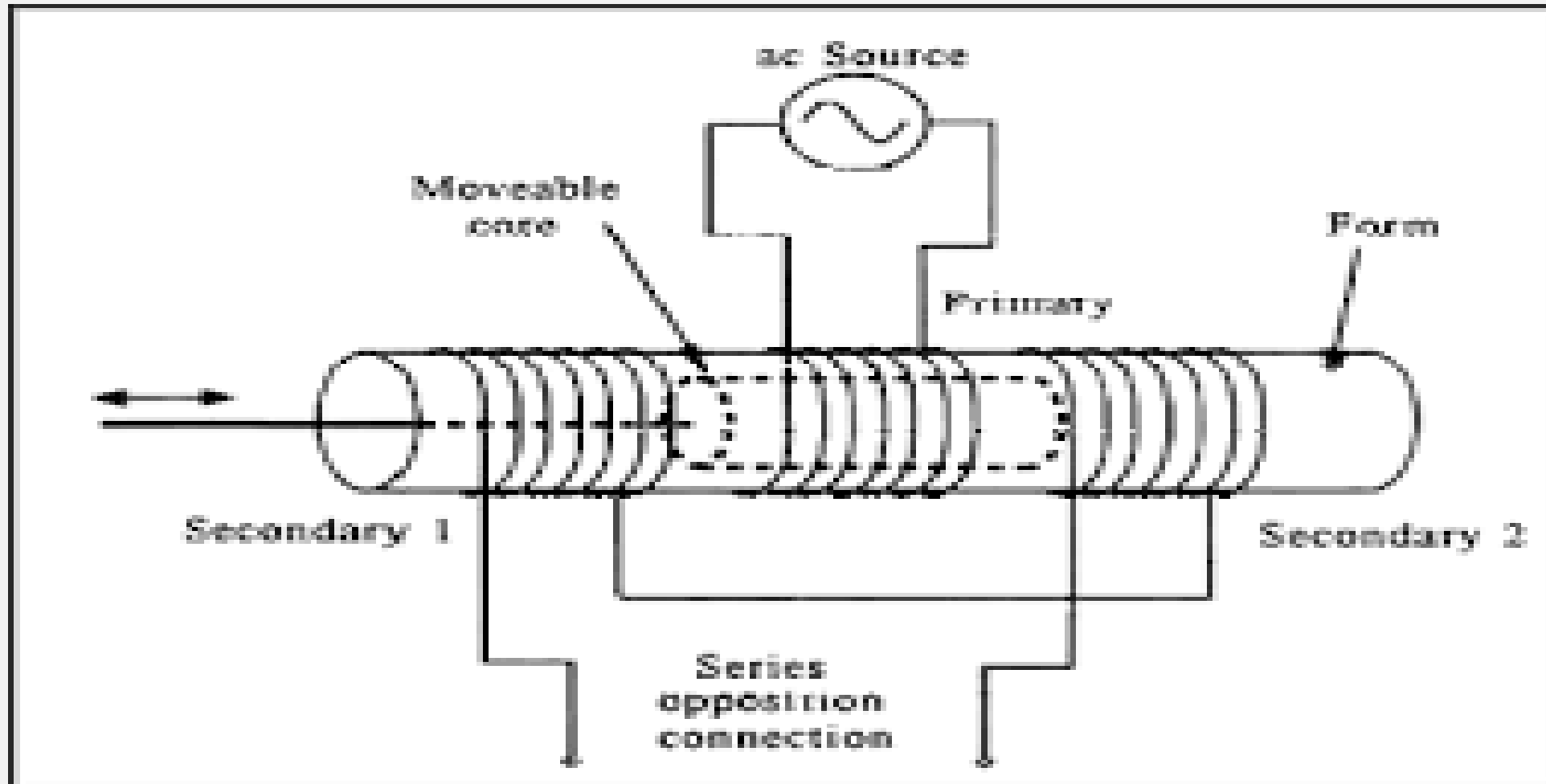

PROCEDURE

1. Connect the terminals marked “PRIMARY” on the front panel of the instrument to the terminals marked “PRIMARY” on the transducer itself with the help of the flexible wires provided along with observe the color code for the wires provided &the color of binding posts.
 2. Identically establish connections from terminals marked “SECONDARY”. Observe the Color of the binding posts.
 3. Keep post marked “MAX” in most anticlockwise position.
 4. The magnetic core may be displaced &the pointer can be brought to zero position. If the dim is not indicating zero, use potentiometer marked “min” to get a zero on DPM at zero mechanical position.
- If the error is displaced in both directions the meter must show indications with appropriate polarity. Now displace the core to 19mm polarity in one of the directions. Adjust the “max” plot to get an indication of 19mm on DPM under this condition. Now setup is ready for experiment you may again check for zero position also.

PROCEDURE

1. Now the core can be displaced by a known amount in the range of +19mm & -19mm & the meter reading can be entered in the table given below. It may be noted that by exchanging the second terminals (or) the primary. The polarity of the meter indication can be reversed for the given direction of the I/P displacement.
2. For LVDT provided with the dial gauge adjust the magnetic core carefully by rotating the central knob in clockwise direction operates the control knob very carefully.
3. Plot the graph between i/p displacement & o/p displacement between X-axis & Y-axis resp.

PRECAUTIONS

1. While connecting lead wire from pond to the transducer make proper, connections following color code, avoid shorting of the excitation of source terminals.
2. One of the cores with a gentle fashion by operating the knob for core moment very carefully.

RESISTANCE STRAIN GAUGE – STRAIN MEASUREMENT AND CALIBRATION

- **AIM:** Measurement of strain in cantilever beam using strain measurement trainer.

- **APPARATUS:**

S.NO	ITEM NAME
1	Cantilever beam
2	PAN
3	Dead weights
4	A pin connector

CIRCUIT DIAGRAM

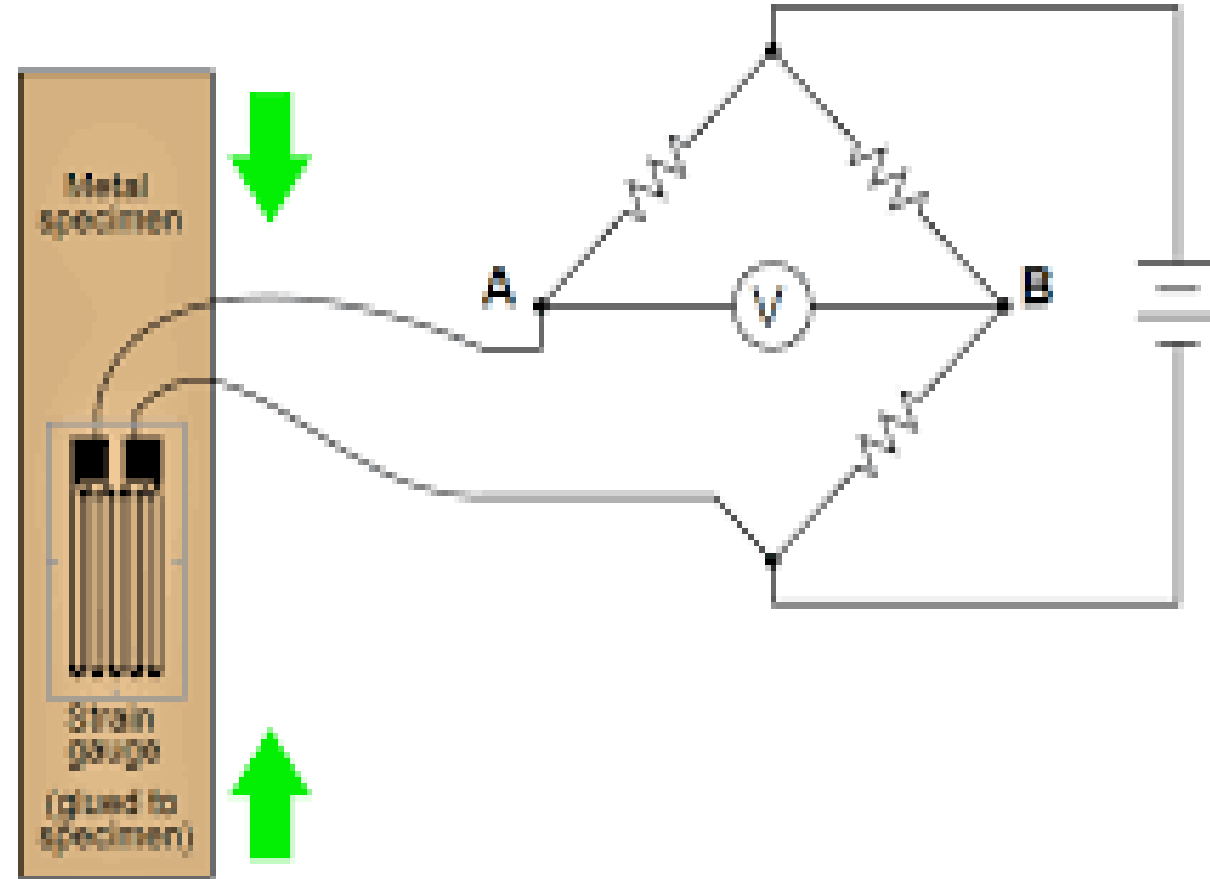

THEORY

- **What Is Strain-**
- Strain is the amount of deformation of a body due to an applied force. More specifically, strain (ϵ) is defined as the fractional change in length, as shown in Figure 1 below.
- Strain can be positive (tensile) or negative (compressive). Although dimensionless, strain is sometimes expressed in units such as in./in. or mm/mm. In practice, the magnitude of measured strain is very small. Therefore, strain is often expressed as micro strain ($\mu\epsilon$), which is $\times 10^{-6}$. When a bar is strained with a uniaxial force, as in Figure 1, a phenomenon known as Poisson Strain causes the girth of the bar, D , to contract in the transverse, or perpendicular, direction. The magnitude of this transverse contraction is a material property indicated by its Poisson's Ratio.

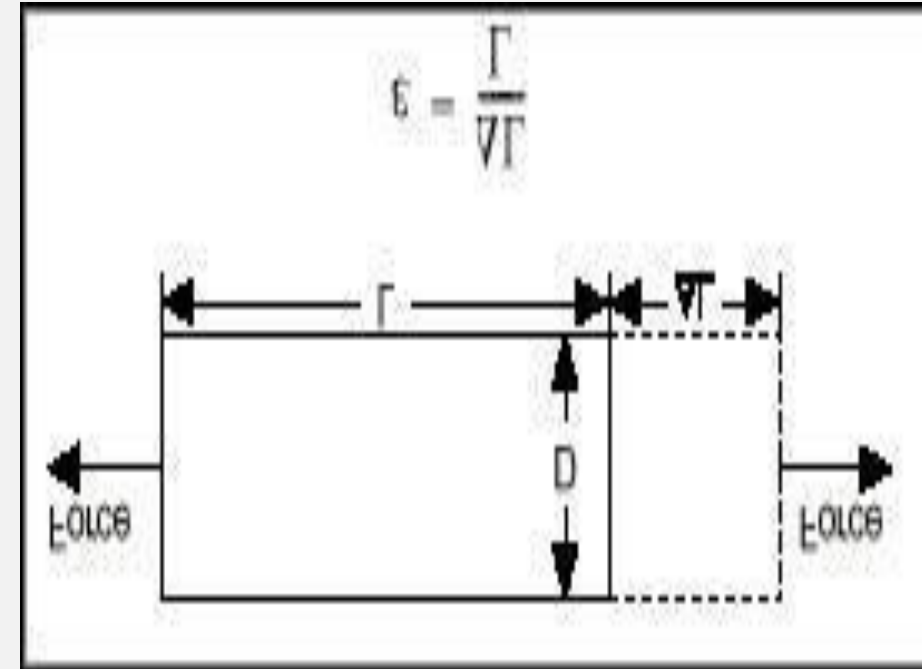



- The Poisson's Ratio ν of a material is defined as the negative ratio of the strain in the transverse direction (perpendicular to the force) to the strain in the axial direction (parallel to the force), or $\nu = -\epsilon_T/\epsilon$. Poisson's Ratio for steel, for example, range from 0.2-0.3. While there are several methods of measuring strain, the most common is with a strain gauge, a device whose electrical resistance varies in proportion to the amount of strain in the device. The most widely used gauge is the bonded metallic strain gauge.

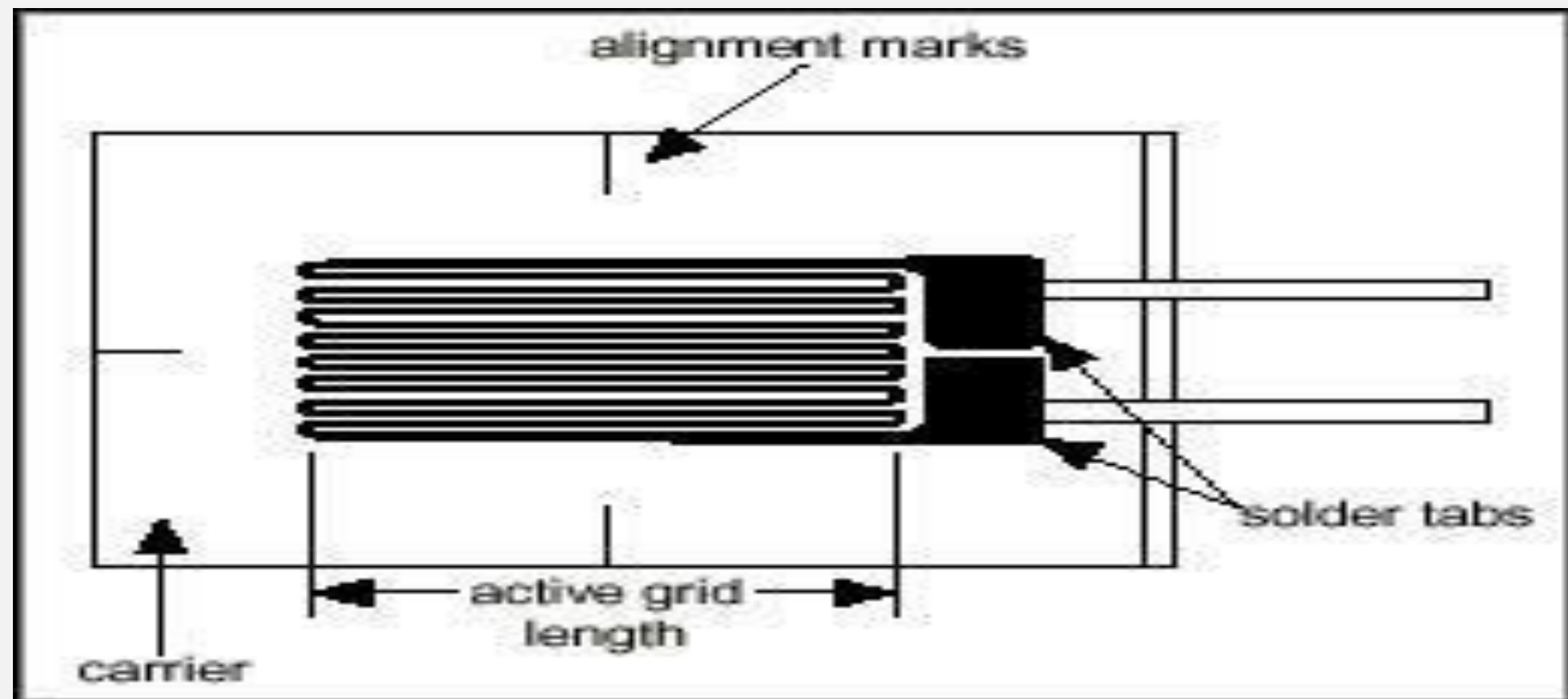

- **CONNECTION DETAILS:**

1. Connect the 3 pin power supplied to 230V supply and to the instrument at the main panel.
2. Connect the strain gauge to the terminals at the measurement panel as follows.

- **For full bridge configuration:**

- Strip Red and Blue wires and connect them to Red terminal on the panel. Match the other wire colors' with terminals.

- **For half bridge configuration:**

- Disconnect Blue and Green wires from the terminals

PROCEDURE

1. Check the connections made and switch on the instrument by toggle switch at the back of the box. This display glows to indicate the instrument is ON.
 2. Allow the instrument in the ON position for 10min for initial warm-up.
 3. Select the full or half bridge configuration from the selector switch on the panel.
 4. Adjust the zero potentiometer on the panel till the display reads '000'.
 5. Apply 1Kg load on the cantilever beam and adjust the cal potentiometer till the display should come to '0' in case of any variation adjust the zero potential again and repeat the procedure again. Now, the instrument is calibrated to read micro-strain.
 6. Apply load on the sensor using the loading arrangement provided in steps of 100grams up to 1Kg.
 7. The instrument displays exact micro strain strained by the cantilever beam (for full bridge configuration and for half bridge configuration).
- Note down the readings in the tabular column percentage error in the reading hysteresis and accuracy of the instrument can be calculated by comparing with the theoretical values