

LABORATORY DEMONSTRATION

ON

AC MACHINES (20A02402P)

By

Dr S.Mallikarjunaiah

Professor

Department of EEE

VEMU IT ,CHITTOOR

Vision of the Institute

To be a premier institute for professional education producing dynamic and vibrant force of technocrat with competent skills, innovative ideas and leadership qualities to serve the society with ethical and benevolent approach.

Mission of the Institute

Mission_1: To create a learning environment with state-of-the-art infrastructure, well equipped laboratories, research facilities and qualified senior faculty to impart high quality technical education.

Mission_2: To facilitate the learners to foster innovative ideas, inculcate competent research and consultancy skills through Industry-Institute Interaction.

Mission_3: To develop hard work, honesty, leadership qualities and sense of direction in rural youth by providing value based education.

Vision of the Department

To produce professionally deft and intellectually adept Electrical and Electronics Engineers and equip them with the latest technological skills, research & consultancy competencies along with social responsibility, ethics, Lifelong Learning and leadership qualities.

Mission of the Department

Mission_1: To produce competent Electrical and Electronics Engineers with strong core knowledge, design experience & exposure to research by providing quality teaching and learning environment..

Mission_2: To train the students in emerging technologies through state - of - the art laboratories and thus bridge the gap between Industry and academia.

Mission_3: To inculcate learners with interpersonal skills, team work, social values, leadership qualities and professional ethics for a holistic engineering professional practice through value based education

Programme Educational Objectives (PEOs)

PEO_1: Provide sound foundation in mathematics, science and engineering fundamentals to analyze, formulate and solve complex engineering problems.

PEO_2: Have multi-disciplinary Knowledge and innovative skills to design and develop Electrical & Electronics products and allied systems.

PEO_3: Acquire the latest technological skills and motivation to pursue higher studies leading to research.

PEO_4: Possess good communication skills, team spirit, ethics, modern tools usage and the life-long learning needed for a successful professional career.

- PO_1: Engineering knowledge:** Apply the knowledge of mathematics, science, engineering fundamentals, and an engineering specialization to the solution of complex engineering problems.
- PO_2: Problem analysis:** Identify, formulate, review research literature, and analyze complex engineering problems reaching substantiated conclusions using first principles of mathematics, natural sciences, and engineering sciences.
- PO_3: Design/development of solutions:** Design solutions for complex engineering problems and design system components or processes that meet the specified needs with appropriate consideration for the public health and safety, and the cultural, societal, and environmental considerations.
- PO_4: Conduct investigations of complex problems:** Use research-based knowledge and research methods including design of experiments, analysis and interpretation of data, and synthesis of the information to provide valid conclusions.
- PO_5: Modern tool usage:** Create, select, and apply appropriate techniques, resources, and modern engineering and IT tools including prediction and modeling to complex engineering activities with an understanding of the limitations.
- PO_6: The engineer and society:** Apply reasoning informed by the contextual knowledge to assess societal, health, safety, legal and cultural issues and the consequent responsibilities relevant to the professional engineering practice.
- PO_7: Environment and sustainability:** Understand the impact of the professional engineering solutions in societal and environmental contexts, and demonstrate the knowledge of, and need for sustainable development.
- PO_8: Ethics:** Apply ethical principles and commit to professional ethics and responsibilities and norms of the engineering practice.
- PO_9: Individual and team work:** Function effectively as an individual, and as a member or leader in diverse teams, and in multidisciplinary settings.
- PO_10: Communication:** Communicate effectively on complex engineering activities with the engineering community and with society at large, such as, being able to comprehend and write effective reports and design documentation, make effective presentations, and give and receive clear instructions.
- PO_11: Project management and finance:** Demonstrate knowledge and understanding of the engineering and management principles and apply these to one's own work, as a member and leader in a team, to manage projects and in multidisciplinary environments.
- PO_12: Life-long learning:** Recognize the need for, and have the preparation and ability to engage in independent and life-long learning in the broadest context of technological change

Programme Specific Outcome(PSOs)

PSO_1: Higher Education: Apply the fundamental knowledge of Mathematics, Science, Electrical and Electronics Engineering to pursue higher education in the areas of Electrical Circuits, Electrical Machines, Electrical Drives, Power Electronics, Control Systems and Power Systems.

PSO_2: Employment: Get employed in Public/Private sectors by applying the knowledge in the domains of design and operation of Electronic Systems, Microprocessor based control systems, Power systems, Energy auditing etc.

Department of Electrical and Electronics Engineering

VEMU INSTITUTE OF TECHNOLOGY::P.KOTHAKOTA

NEAR PAKALA, CHITTOOR-517112

(Approved by AICTE, New Delhi & Affiliated to JNTUA, Anantapuramu)

JAWAHARLAL NEHRU TECHNOLOGICAL UNIVERSITY ANANTAPUR

B. Tech II-II Sem. (EEE)

L T P C

0 0 3 1.5

20A02402PAC MACHINES LAB

Course Objective:

To experiment in detail on Induction Motors, Alternators and Synchronous Motors, and evaluate their performance characteristics.

The following experiments are required to be conducted as compulsory experiments:

1. No-load & Blocked-rotor tests on Squirrel cage Induction Motor.
2. Load test on three phase slip ring Induction Motor.
3. Speed control of three phase Induction Motor.
4. Rotor resistance starter for slip ring Induction Motor.
5. Load test on single phase Induction Motor.
6. Determination of equivalent circuit of a single-phase induction motor.
7. Predetermination of regulation of a three-phase alternator by synchronous impedance & M.M.F methods.
8. Predetermination of Regulation of three phase alternator by Z.P.F. method.
9. Determination of X_d and X_q of a salient pole synchronous machine.
10. V and inverted V curves of a 3-phase synchronous motor.

Additional Experiments

11. Separation of No Load Losses of Three Phase Induction Motor
12. Synchronization of Alternator with Infinite Bus by Bright Lamp Method.

Exp. No.: 01

Date:

NO-LOAD & BLOCKED ROTOR TESTS ON 3-Ø INDUCTION MOTOR

Aim:

To draw the equivalent circuit of a 3-Ø Induction Motor and construct the circle diagram by conducting No-Load & Blocked Rotor Tests.

Apparatus:

S. No.	Name of the Equipment	Range	Type	Quantity
1	3-Ø Variac	415V/(0-470)V	-	1
2	Ammeter	(0-10)A	MI	1
		(0-5)A	MC	1
3	Voltmeter	(0-600)V	MI	1
		(0-150)V	MI	1
4	Wattmeter	600V/10A	LPF	2
		300V/10A	UPF	2
5	Connecting Wires	-	-	Required Some

Circuit Diagram:

No-Load Test:

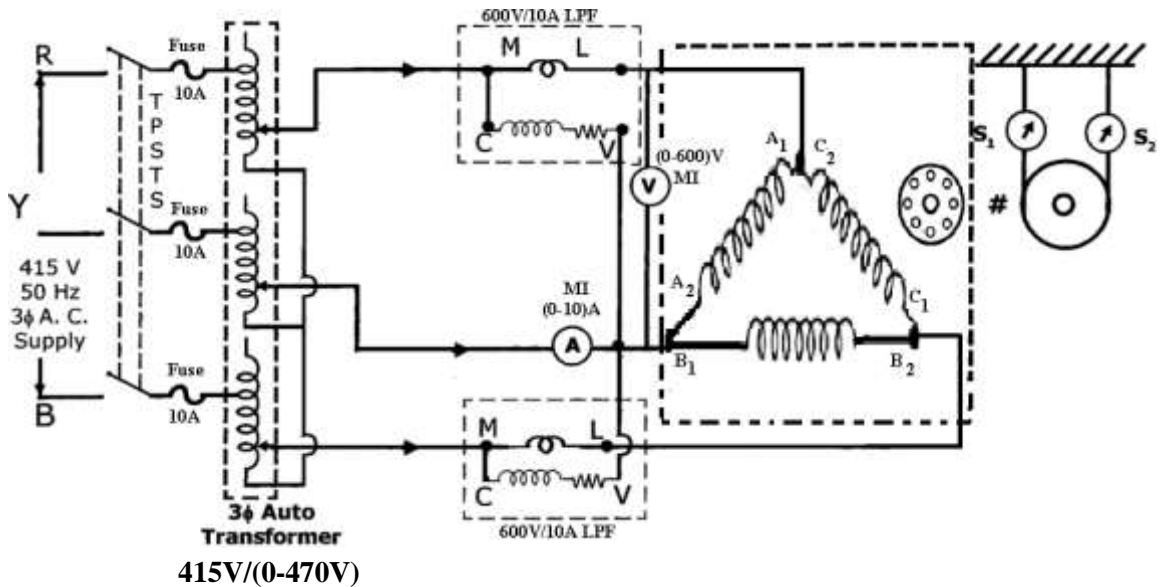

Blocked Rotor Test:

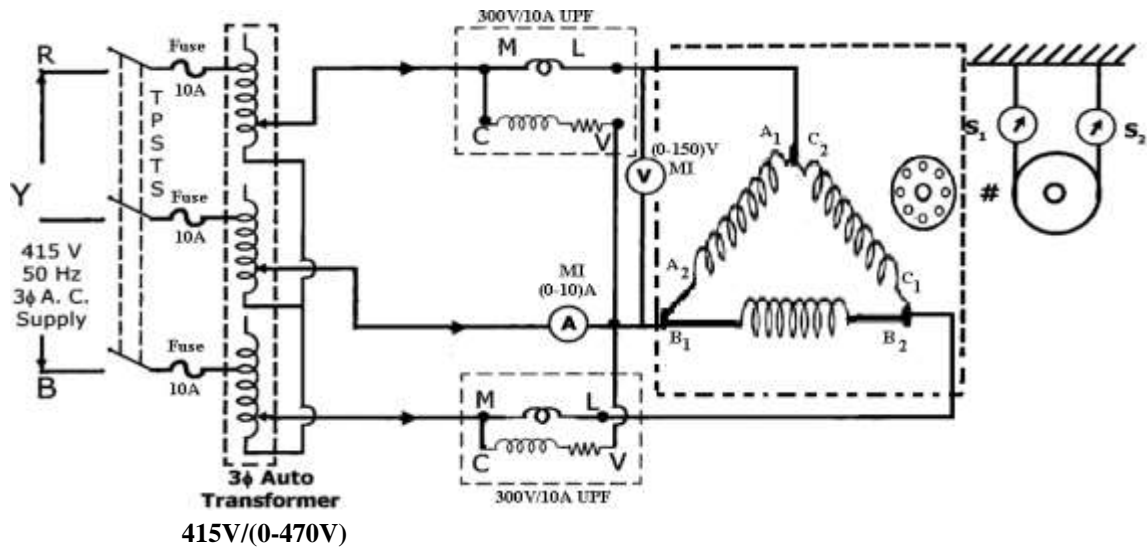

To find stator resistance per phase:

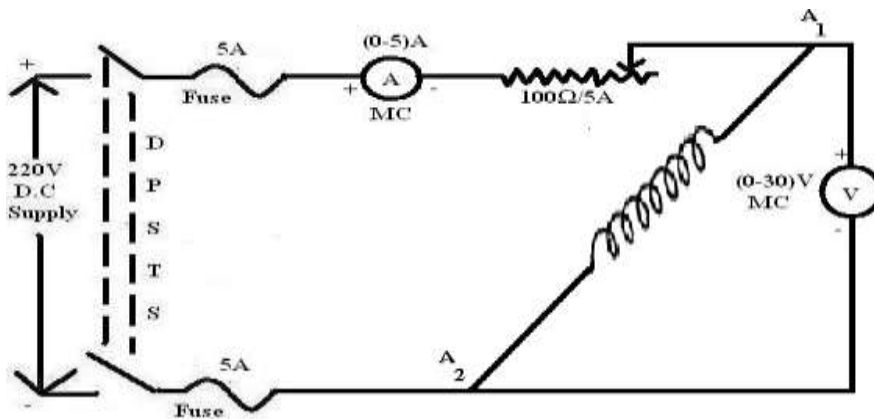

Name plate details:

Precautions:

1. 3-Ø Variac should be in minimum position.
2. Note down the readings without parallax errors.

Procedure:

No-Load Test:

1. Connect the circuit as shown in circuit diagram.
2. Observing the precautions close the TPST Switch and switch ON 440V A.C Supply.
3. Apply the rated voltage to the stator windings of 3- Ø Induction Motor with the help of 3- Ø Auto-Transformer.
4. Note down the no-load readings of wattmeter, ammeter and voltmeter.
5. Bring back the auto-transformer to its minimum position and switch OFF the supply.

Blocked Rotor Test:

1. Connect the circuit as shown in circuit diagram.
2. Observing the precautions close the TPST Switch and switch ON 440V A.C Supply.
3. By varying the variac, apply small voltage until the full load current flows in the stator windings with the rotor unmoved.
4. Note down the readings and switch OFF the supply after bringing back the auto-transformer output to minimum position.

Tabular Column:

No-Load Test:

I_o (A)	V (V)	W₁ (W)	W₂ (W)

Blocked Rotor Test:

Current, I_{SC} (A)	Voltage, V_{SC} (V)	W₁ (W)	W₂ (W)

Stator Resistance per phase =

Formulae:

$$G_o = \frac{W_o}{3V^2} \quad ; \quad Y_o = \frac{I_o}{V} \quad ; \quad B_o = \sqrt{(Y_o^2 - G_o^2)}$$

$$Z_{01} = \frac{V_{SC}}{I_{SC}} \quad ; \quad R_{01} = \frac{W_{SC}}{3I_{SC}^2} \quad ; \quad X_{01} = \sqrt{(Z_{01}^2 - R_{01}^2)}$$

For Circle Diagram:

$$\cos \phi_o = \frac{W_o}{\sqrt{3} V_o I_o}$$

$$\cos \phi_{SC} = \frac{W_{SC}}{\sqrt{3} V_{SC} I_{SC}}$$

$$I_{SN} = I_{SC} [V_o / V_{sc}]$$

Result:

Viva Voce Questions:

1. What is the importance of circle diagram?
2. Define Faraday's laws of electromagnetic induction.
3. What are the Tests to be conducted to plot the circle diagram?
4. Which type of wattcmeters is used to conduct blocked rotor test and no-load test.
5. What is the necessity to conduct the blocked rotor test and no-load test?
6. Condition for maximum torque in I.M.
7. What is the reason for high No load current in I.M compare to the Transformer?
8. Formula for calculation of I.M torque at starting and running.
9. What is value of slip at blocked rotor test?
10. What is value of slip at No load test?

Exp. No.: 02

Date:

LOAD TEST ON 3-PHASE SLIPRING INDUCTION MOTOR

Aim:

To Perform Load Test on 3 Phase Slipring Induction Motor.

Apparatus:

S. No.	Name of the Equipment	Type	Range	Quantity
1	Ammeter	MI	(0-10) A	1 no
2	Voltmeter	MI	(0-600) V	1 no
3	Wattmeter	Electro dynamo meter type	10A/600V UPF	2 no
4	Tachometer	Digital	(0-10000)RPM	1 no
5	Connecting Wires	*****	(0-20)A	Required

Circuit Diagram:

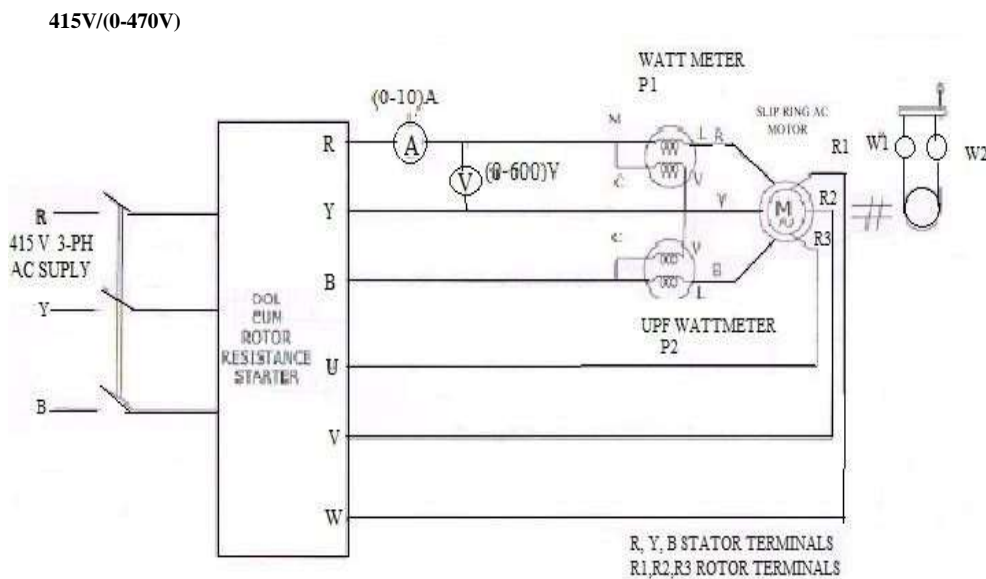

Procedure:

1. Connect the circuit as per circuit diagram.
2. Adjust 'Zero set' for Balances.
3. Switch on Mains supply.
4. To Start AC Motor, press START Push Button & Shift position of Rotor resistance s/w from 1 to 2 to 3 to 4. Resistance is cut out and rotor is short circuited at position – 4
5. Note down readings of voltmeter, Ammeter, Wattmeter's & load on balances W1 & W2 Kg.
6. Using hand wheel of Brake drum arrangement load the motor in steps from no load to rated torque.
7. Rated torque $T = (W1-W2) * A$
 $A = \text{Break drum Constant} = \text{Radius of Pulley (Meter)} * 9.81$
8. At each step repeat Step 5.
9. Calculate power output $P = 2\pi NT/60$.
10. Calculate efficiency = output / input.

Tabular Columns:

S NO	Line Volts V _L	Line Amps I _L	Wattmeter's Readings		I/P Power W ₁ + W ₂	Load S ₁ Kg	Load S ₂ Kg	S ₁ ~ S ₂	Speed RPM	Torque N-m	Output Power	%η
			W ₁	W ₂								

Formulae:

Input power drawn by the motor $W = (W_1 + W_2)$ watts

Shaft Torque, $T_{sh} = 9.81 (S_1 \sim S_2) R$ N-m, Where R is radius of drum in meters

Output power in watts = $2\pi N T_{sh}/60$ watts

Efficiency = (Output power in watts/ Input Power in watts) x 100

% Slip = $(N_s - N)/N_s * 100$

Power factor of the induction motor $\cos\theta = W/\sqrt{3}V_L I_L$

Model Graph:

1. Speed or slip Vs output power
2. Torque Vs output power
3. % Efficiency Vs output power

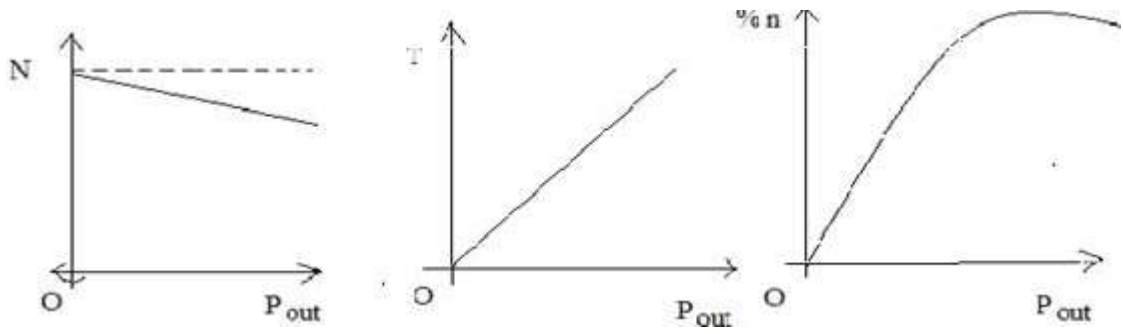

CALCULATIONS:

Precautions:

1. Connections must be made tight
2. Before making or breaking the circuit, supply must be switched off

Result:

Viva Voce Questions:

1. Why starter is used? What are different types of starters?
2. Compare a slip ring induction motor with cage induction motor?
3. Why the starting torque is zero for a Single-Phase induction motor and non-zero of 3phase induction motor?
4. What are the disadvantages of this method?
5. Can we use rotor resistance method for starting?

Exp. No.: 03

Date:

SPEED CONTROL OF THREE PHASE SLIP RING INDUCTION MOTOR

Aim:

To control the speed of a 3-phase slip ring induction motor by rotor resistance control.

Apparatus:

S.NO	NAME OF THE APPARATUS	TYPE	RANGE	QUANTITY
1	Ammeter	MI	(0-10A)	1
2	Voltmeter	MI	(0-600V)	1
3	Rotor Resistance Starter	-	-	1
4	Tachometer	Digital	-	1
5	Connecting Leads	-	-	Required

Circuit Diagram:

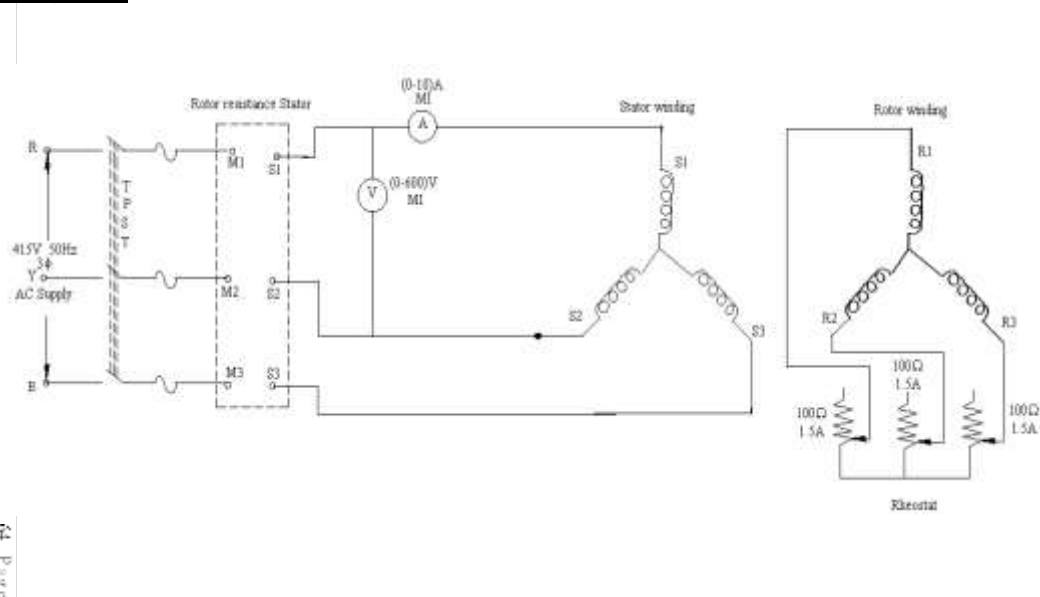

Precautions:

The motor input current should not exceed its rated value.

Procedure:

1. Connections are given as per the circuit diagram.
2. Keep the rotor resistance stator output as zero voltage & the external rotor resistance at minimum resistance position.
3. Switch ON the supply & increase the input voltage to stator winding upto its rated value.
4. Measure the speed.
5. Now increase the rotor resistance in steps & note the corresponding values of speed.
6. Draw a graph of rotor resistance versus speed.

Tabular Columns:

S.NO.	EXTERNAL ROTOR RESISTANCE IN OHMS	SPEED (RPM)

Graph:

- Draw a graph of rotor external resistance versus speed.

Result:

Viva Voice Questions:

- 1) What will happen if the rotor circuit of a slip ring I.M. is kept open & electric supply is given to its stator winding.
- 2) What is the constructional difference between a slip-ring & a squirrel cage I.M.
- 3) Draw & explain the Torque-speed characteristic of a slip ring I.M. for different values of rotor resistance.
- 4) What is the effect of changing the rotor resistance on the slip at max torque?
- 5) Can a I.M. rotate at synchronous speed? Justify your answer.

Exp. No.: 04

Date:

ROTOR RESISTANCE STARTER FOR SLIP RING INDUCTION MOTOR

Aim:

To Study the Rotor Resistance Starter for Slip Ring Induction Motor.

NECESSITY OF STARTER:

In a three-phase induction motor, the magnitude of an induced e.m.f. in the rotor circuit depends on the slip of the induction motor. This induced e.m.f. effectively decides the magnitude of the rotor current. The rotor current in the running condition is given by,

$$I_2 = E_r / Z_r$$

But at start, the speed of the motor is zero and slip is at its maximum i.e. unity. So magnitude of rotor induced e.m.f. is very large at start. As rotor conductors are short circuited, the large induced e.m.f. circulates very high current through rotor at start.

The condition is exactly similar to a transformer with short circuited secondary. Such a transformer when excited by a rated voltage, circulates very high current through short circuited secondary. As secondary current is large, the primary also draws very high current from the supply.

Similarly in a three-phase induction motor, when rotor current is high, consequently the stator draws a very high current from the supply. This current can be of the order of 5 to 8 times the full load current, at start.

Due to such heavy inrush of current at start there is possibility of damage of the motor winding. Similarly, such sudden inrush of current causes large line voltage drops. Thus, other appliances connected to the same line may be subjected to voltage spikes which may affect their working. To avoid such effects, it is necessary to limit the current drawn by the motor at start. The starter is a device which is basically used to limit high starting current by supplying reduced voltage to the motor at the time of starting. Such a reduced voltage is applied only for short period and once rotor gets accelerated, full normal rated voltage is applied.

Not only the starter limits the starting current but also provides the protection to the induction motor against overt loading and low voltage situations. The protection against single phasing is also provided by the starter. The induction motors having rating below 5

h.p. can withstand starting currents hence such motors can be started directly on line. But such motors also need overload, single phasing and low voltage protection which is provided by a starter.

Circuit Diagram:

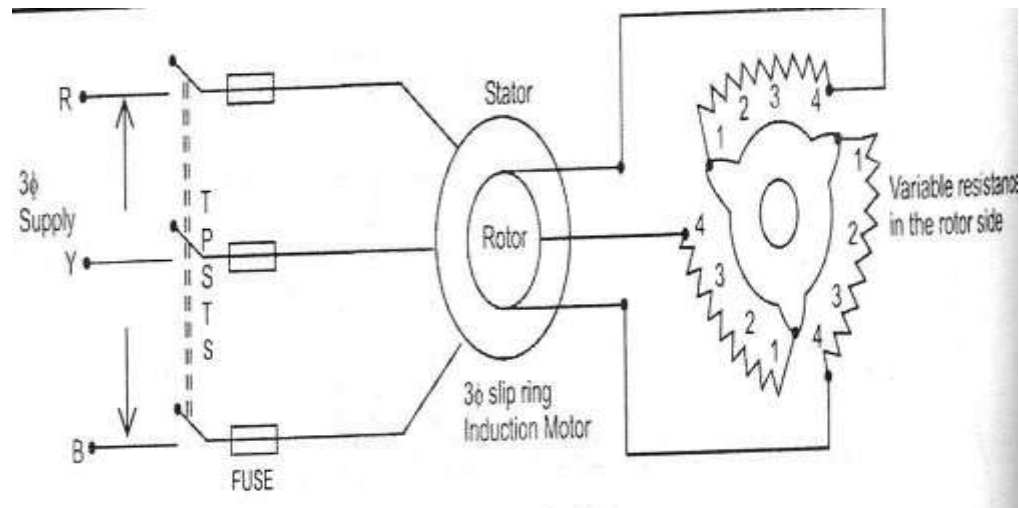

ROTOR RESISTANCE STARTER:

To limit the rotor current which consequently reduces the current drawn by the motor from the supply, the resistance can be inserted in the rotor circuit at start. This addition of the resistance in rotor is in the form of 3 phase star connected rheostat. The arrangement is shown in the Fig.3.4. The external resistance is inserted in each phase of the rotor winding through slip ring and brush assembly. Initially maximum resistance is in the circuit. As motor gathers speed, the resistance is gradually cutoff. The operation may be manual or automatic. We have seen that the starting torque is proportional to the rotor resistance. Hence important advantage of this method is not only the starting current is limited but starting torque of the motor also gets improved. The only limitation of the starter is that it can be used only for slip ring induction motors as in squirrel cage motors, the rotor is permanently short circuited.

RESULT:

Exp. No.: 05

Date:

LOAD TEST ON SINGLE PHASE INDUCTION MOTOR

Aim:

To conduct the direct load test on the given single phase induction motor and to determine and plot its performance characteristics.

Apparatus:

Sl. No.	Equipment	Type	Range	Quantity
1	Voltmeter	MI	(0-300)V	1 no
2	Ammeter	MI	(0-10)A	1 no
3	Tachometer	Digital	0-9999 RPM	1 no
4	Wattmeter	Dynamo-type	(0-150)V UPF (0-10)A	1 no
5	Connecting Wires	*****		Required

Name Plate details:

Circuit Diagram:

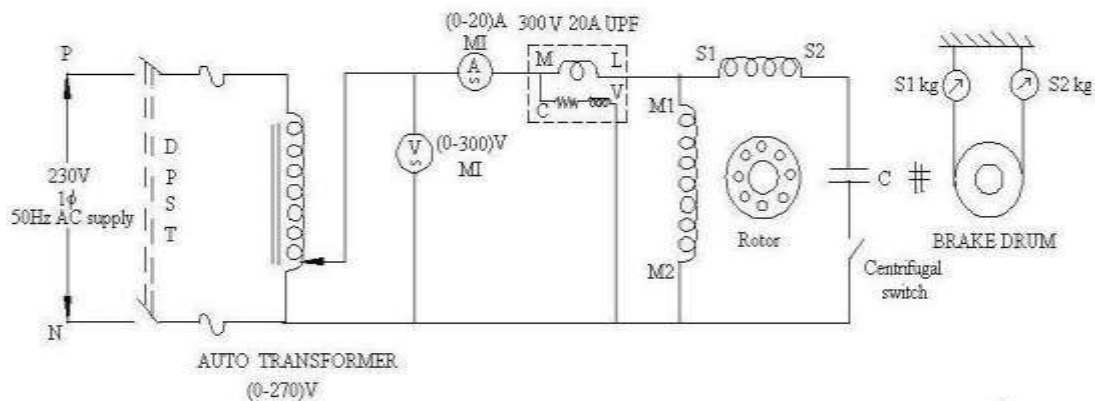

Precautions:

1. Field rheostat must be kept in minimum resistance position.
2. Armature rheostat must be kept in maximum resistance position.
3. Initially Rectifier should be in zero voltage position.

Procedure:

1. Connections are given as per the circuit diagram.
2. Switch on the supply at no load condition.
3. Apply the rotor voltage to the motor using the single phase variac and note down the readings of ammeter And wattmeter.
4. Vary the load in suitable steps and note down all the meter readings till full load condition.

Tabular Columns:

S. No	V _L Volts	I _L Amps	S ₁ kg	S ₂ kg	S kg	W watts	Speed rpm	Torque Nm	P _o watts	%η

Formulae:

Torque = $9.81 \times (S_1 - S_2) \times R$ Nm, where R is the radius brake drum in meter

Output power, P_o = $2\pi NT/60$ Watts

Input power, P = W₁ + W₂ Watts

Efficiency = (output power/input power) × 100

% Slip = $(N_s - N)/N \times 100$

Power factor = $\cos \phi = W/VI$

Model Graph:

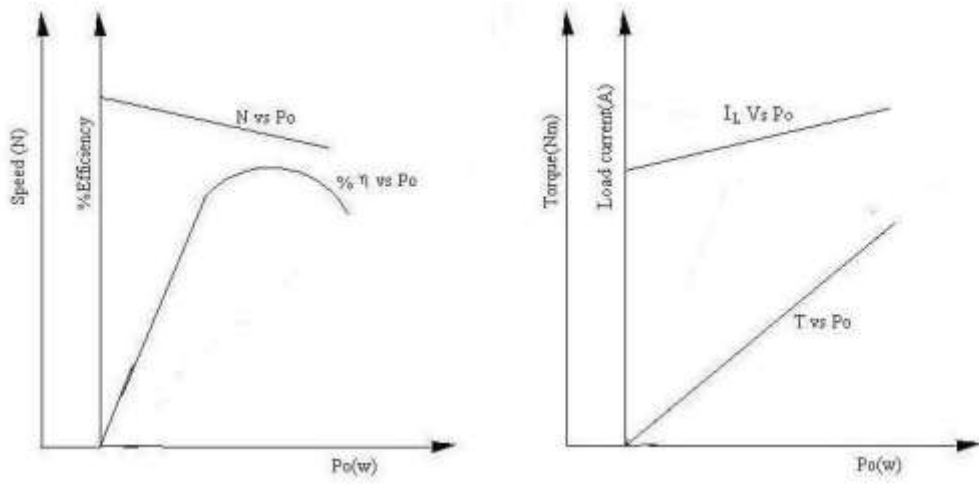

Calculations:

Result:

Viva Voce Questions:

1. What is the purpose of this experiment?
2. Whether single phase induction motor self starting motor?
3. What are the starting methods of single-phase induction motor?

Exp. No.: 06

Date:

EQUIVALENT CIRCUIT OF A 1- Ø INDUCTION MOTOR

Aim:

To determine the equivalent circuit parameters of a 1- Ø induction motor by conducting No-Load, Blocked rotor and Stator resistance measurement tests.

Apparatus:

S. No.	Name of the Equipment	Range	Type	Quantity
1	1- Ø Variac	230V/(0-270)V, 20A	-	1
2	Voltmeter	(0-300)V	MI	1
		(0-150)V	MI	1
3	Ammeter	(0-10)A	MI	1
		(0-20)A	MI	1
4	Wattmeter	300V/10A	LPF	1
		75V/20A	UPF	1
5	Connecting Wires	-	-	Required Some

Circuit Diagram:

No-load Test:

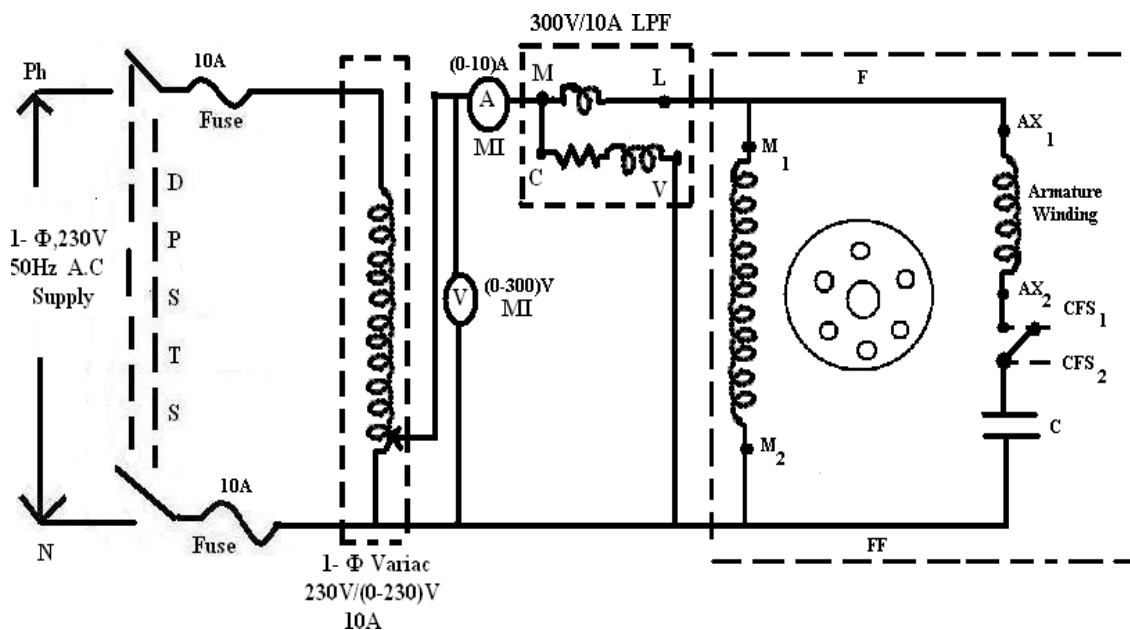

Blocked Rotor Test:

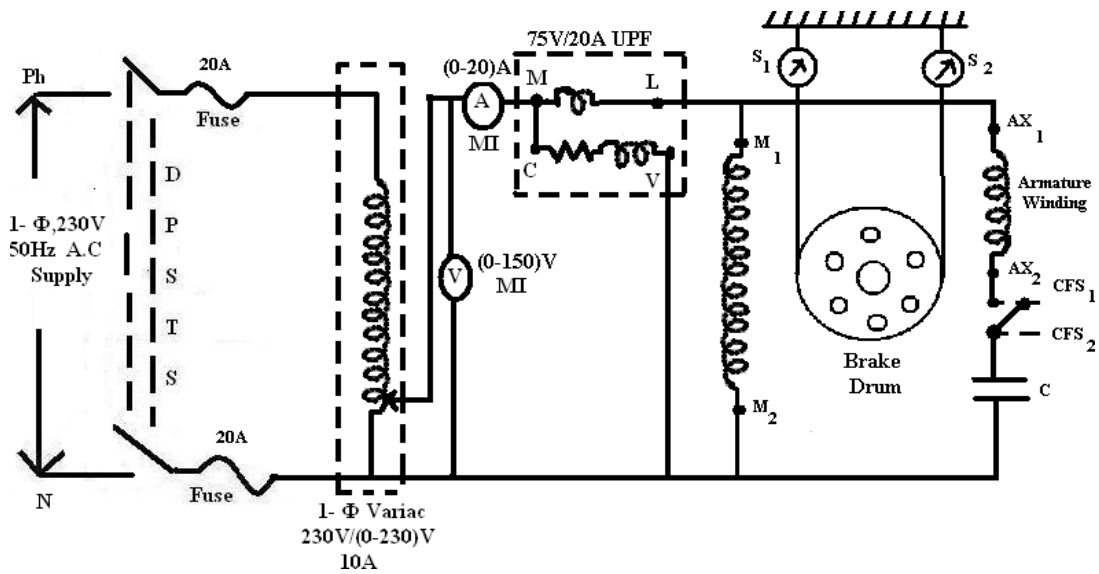

To find stator resistance:

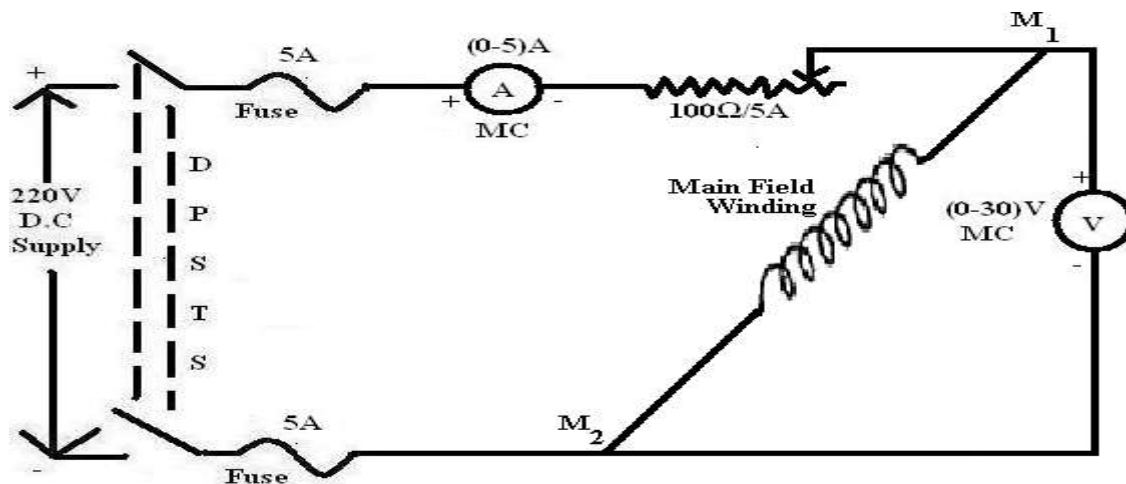

Name plate details:

Precautions:

1. Initially variac must be at zero position.
2. No Loose connections are allowed.
3. Readings should be taken without any parallax errors.
4. Rheostat should be in maximum resistance position.

Procedure:

For No-Load Test:

1. Connect the circuit as shown in circuit diagram.
2. Observing the precautions close the DPST Switch and switch ON 1- Ø A.C supply.
3. Apply the rated voltage by increasing the variac output gradually (No Load is connected to the motor).
4. Note down the readings of all the meters.
5. Observing the precautions switch OFF the supply.

For Blocked Rotor Test:

1. Connect the circuit as shown in circuit diagram.
2. For performing the blocked rotor test, block the rotor (i.e., not allowed to rotate) by applying belt-brake arrangement and increase the voltage slowly till rated current flows and note down all the meter readings.
3. Observing the precautions switch OFF the supply.

Tabular Columns:

No-Load Test			Blocked Rotor Test		
V _o (V)	I _o (A)	W _o (W)	V _{sc} (V)	I _{sc} (A)	W _{sc} (W)

Formulae:

$$\cos\phi_o = \frac{W_o}{V_o I_o}$$

$$R_o = \frac{V_o}{I_o \cos\phi_o}, X_o = \frac{V_o}{I_o \sin\phi_o}$$

$$Z_s = \frac{V_{sc}}{I_{sc}}$$

$$X_s = \sqrt{Z_s^2 - R_s^2} = X_{eq}$$

$$r_1 = r_2 = \frac{R_s}{2}$$

$$x_1 = x_2 = \frac{X_s}{2}$$

$$slip = \frac{N_s - N}{N_s}$$

$$R_s = R_{eq} = \frac{W_{sc}}{I_{sc}^2}$$

Result:

Viva Voice Questions:

1. What are methods to start the 1-phase induction motor?
2. What is meant by double field revolving theory?
3. What are the advantages of 3-phase induction motor compare to 1-phase induction motor?
4. How the direction of rotation of 1-phase induction motor reverses?
5. What is forward slip and backward slip for 1-phase induction motor?
6. When the slip of induction motor nearer to zero?
7. List out 1-phase induction motors.
8. What are the applications of 1-phase induction motor?
9. Where the auxiliary winding is place in the 1-phase induction motor?
10. Why should a motor be named as universal motor?

Exp. No.: 07

Date:

REGULATION OF 3-PHASE ALTERNATOR BY EMF AND MMF METHODS

Aim:

To predetermine the regulation of 3-phase alternator by EMF and MMF methods and also draw the vector diagrams.

Apparatus:

SL.NO	Name of the Apparatus	Type	Range	Quantity
1	Ammeter	MC	0 – 1/2 A	1
2	Ammeter	MI	0 – 5/10 A	1
4	Voltmeter	MI	0 – 600 V	1
5	Rheostat	Wire wound	400 Ω, 1.5 A	1
6	Rheostat	Wire wound	600Ω, 0.8 A	1
7	Tachometer	Digital	---	1
8	TPST knife switch	--	--	1

Name Plate Details:

Circuit Diagram:

*REGULATION OF THREE PHASE ALTERNATOR BY EMF & MMF METHOD
(Open circuit and Short circuit tests)*

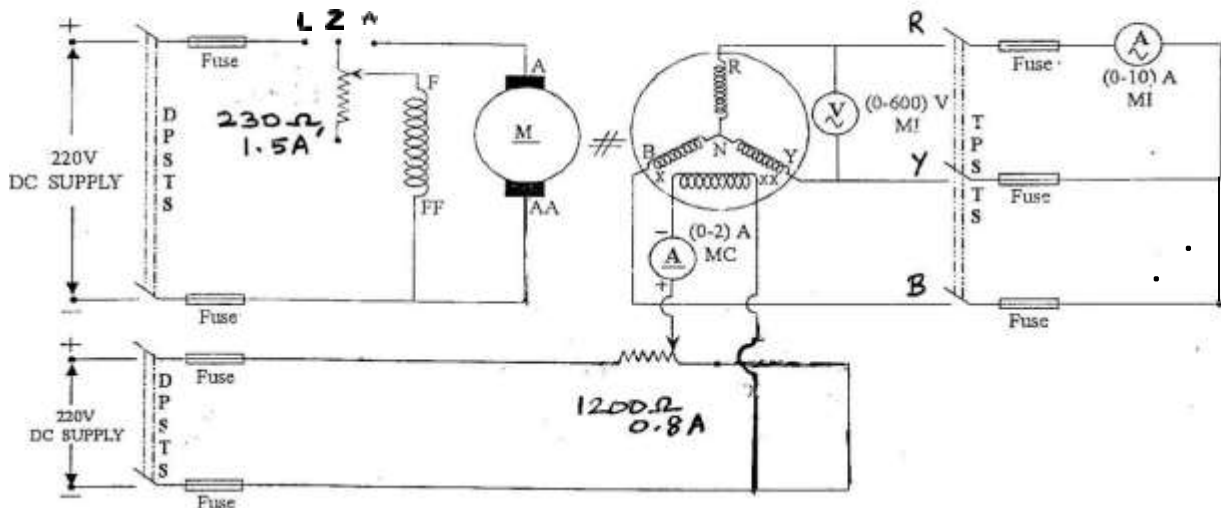

To find Armature Resistance:

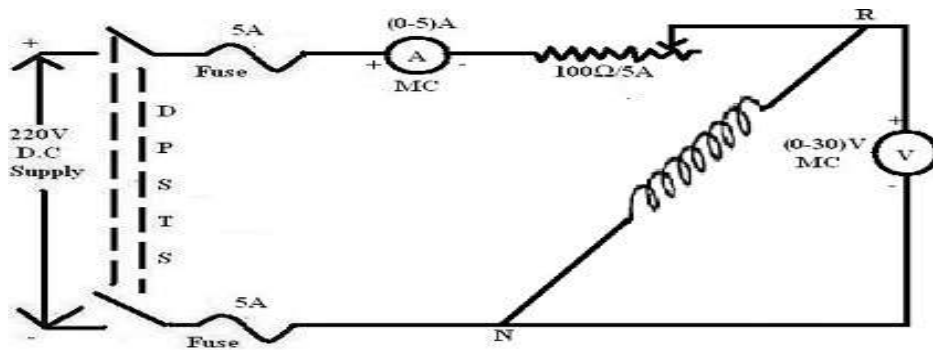

Precautions:

1. The motor field rheostat should be kept in the minimum resistance position.
2. The alternator field potential divider should be kept in the minimum voltage position.
3. Initially all switches are in open position.

Procedure:

1. Note down the name plate details of the motor and alternator.
2. Connections are made as per the circuit diagram.
3. Switch ON the supply by closing the DPST switch.
4. Using three point starter, start the motor to run at the synchronous speed by adjusting the motor field rheostat.
5. Conduct Open Circuit test by varying the potential divider for various values of field current and tabulate the corresponding Open Circuit Voltage readings.
6. Conduct Short Circuit test by closing the TPST switch and adjust the potential divider to set the rated armature current and tabulate the corresponding field current.
7. The Stator resistance per phase is determined by connecting any one phase stator winding of the alternator as per the circuit diagram using MC voltmeter and ammeter of suitable ranges.

Tabular Columns:

O.C Test		
SNO	Field Current I_f (A)	Phase Voltage (V)

S.C Test	
I_f (A)	I_{sc} (A)

E.M.F Method					
P.F cosΦ	I_a (A)	E_o (V)		% Regulation	
		Lagging	Leading	Lagging	Leading

Formulae:

$$Z_s = \frac{V_{oc}}{I_{sc}} \quad \text{for the same } I_f \text{ and speed}$$

$$X_s = \sqrt{Z_s^2 - R_a^2} \quad [R_a = (1.3 \text{ to } 1.6) R_{dc}]$$

Generated E.M.F of alternator on No-Load is given by

$$E_o = \sqrt{(V \cos \Phi + I_a R_a)^2 + (V \sin \Phi \pm I_a X_s)^2}$$

‘+’ for Lagging Power Factor

‘-’ for Leading Power Factor

Percentage regulation of alternator for a given power factor is given by

$$\% \text{ Reg} = \frac{E_o - V}{V} \times 100 \quad (\%)$$

where,

E_o = Generated E.M.F of alternator

(or excitation voltage per phase)

V = Full Load rated terminal voltage per phase.

Model Graph:

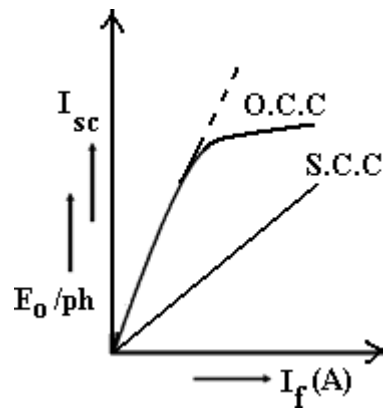

Result:

Viva Voce Questions:

1. What is the difference between the synchronous and induction machines?
2. What are the different types of alternators?
3. Define regulation, Tell me on which principle the alternator works.
4. Define armature reaction
5. What are the different methods for finding the voltage regulation of alternators?
6. What are the difference between DC generator and AC generator?
7. Which method is optimistic method and pessimistic method for V.R of alternator?
8. Define synchronous reactance.
9. Draw the regulation curve for alternator.
10. Define distribution factor and pitch factor.

Exp. No.: 08

Date:

REGULATION OF 3-PHASE ALTERNATOR BY Z.P.F METHOD

Aim:

To predetermine the regulation of three phase alternator by Z.P.F method also to draw the vector diagrams.

Apparatus:

SL. NO	Name of the Apparatus	Type	Range	Quantity
1	Ammeter	MC	0 – 1/2 A	1
2	Ammeter	MI	0 – 5/10 A	1
3	Voltmeter	MC	0 – 10 V	1
4	Voltmeter	MI	0 – 600 V	1
5	Rheostat	Wire wound	250 Ω, 1.5 A	1
6	Rheostat	Wire wound	1200Ω, 0.8 A	1
7	Tachometer	Digital	--	1
8	TPST knife switch	--	--	1

Name Plate Details:

Circuit Diagram:

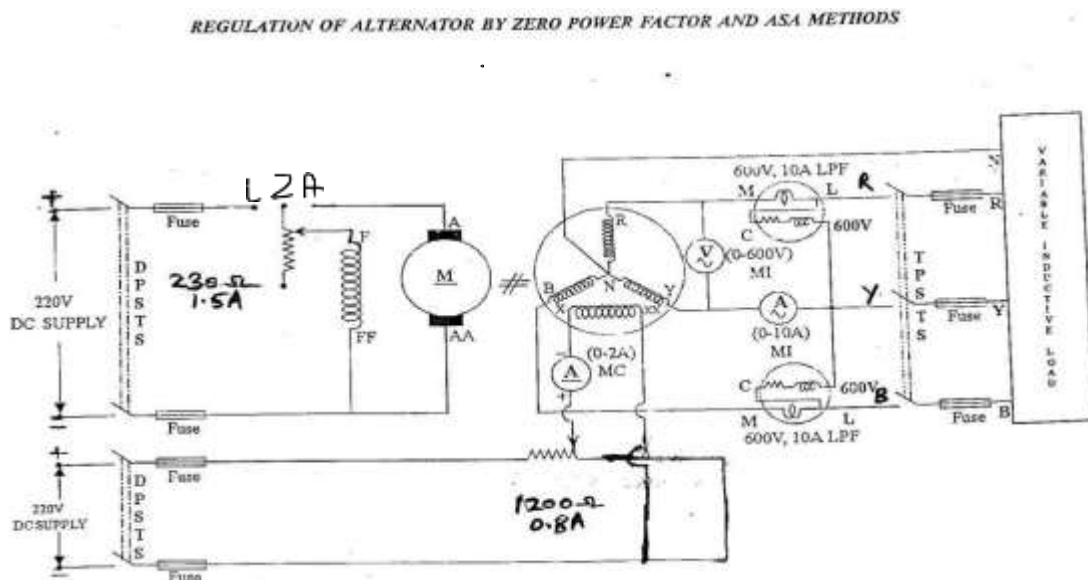

TABULATION:

OPEN CIRCUIT TEST:

S.No	Field Current(I_f)	Open Circuit Line Voltage, $(V_{oc})_L$	Open Circuit Phase Voltage $(V_{oc})_{ph} = (V_{oc})_L / \sqrt{3}$
	Amps	Volts	Volts

SHORT CIRCUIT AND ZPF TEST:

S.No	Short Circuit Test		Zero Power Factor Test		
	Field Current (I_f)	Short Circuit Current (I_{sc})	Field Current (I_f)	Rated Armature current (I_a)	Rated Armature Voltage
	Amps	Amps	Amps	Amps	Volts

Precautions:

1. The motor field rheostat should be kept in minimum resistance position.
2. The alternator field rheostat should be in the maximum resistance position.
3. Initially all switches are in open position.

Procedure:

1. Connections are made as per the circuit diagram.
2. Supply is given by closing the DPST switch.
3. Using three point starter, start the motor to run at the synchronous speed by varying the motor field rheostat.
4. Conduct an open circuit test by varying the potential divider for various loads of field current and tabulate the corresponding open circuit voltage readings.
5. Conduct a short circuit test by closing the TPST switch and adjust the potential divider to set the rated armature current and tabulate the corresponding field current.
6. Conduct a ZPF test by adjusting the potential divider for full load current passing through either inductive or capacitive load with zero power and tabulate the readings.
7. Conduct a Stator Resistance test by giving connection as per the circuit diagram and tabulate the voltage and current readings for various resistive loads.

TO FIND OUT THE ARMATURE RESISTANCE (R_a):

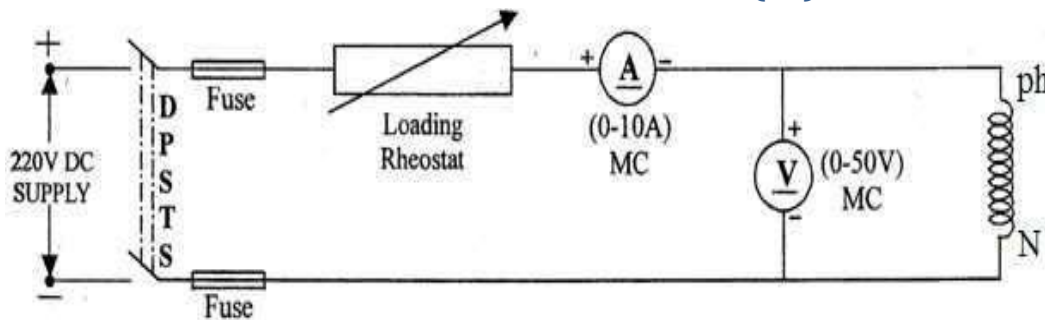

TABULATION TO FIND OUT THE ARMATURE RESISTANCE (R_a):

S.No	Armature Current (I)	Armature Voltage (V)	Armature Resistance $R_a = V/I \Omega$
	Amps	Volts	Ohms

Model Calculations:

MODEL GRAPH:

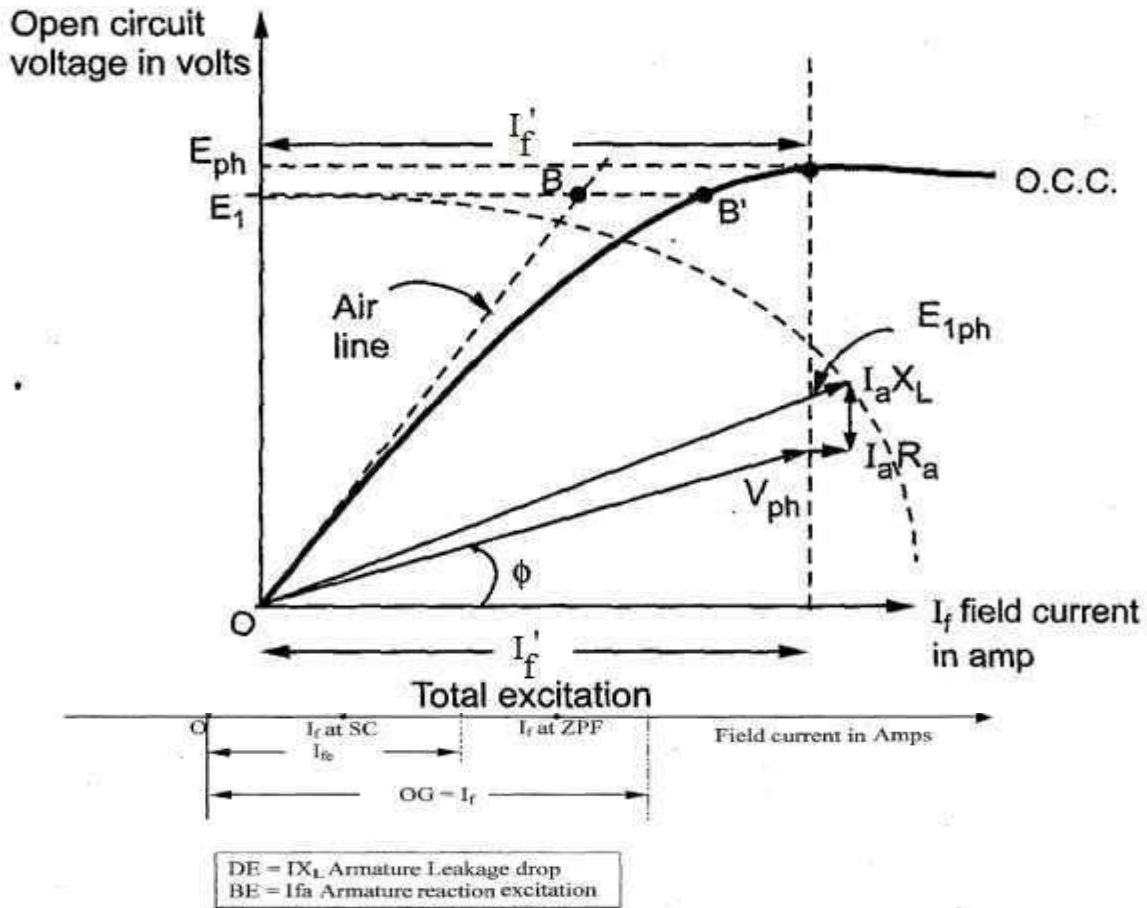

MODEL GRAPH FOR % REGULATION:

S. No	Power Factor	E _{1 ph} Volts		I _{f1} (A)		I _{f2} (A)	I _f (A)		l(BB')		I _f ' (A)		E _{ph} (V)		% Reg	
		Lag	Lead	Lag	Lead		Lag	Lead	Lag	Lead	Lag	Lead	Lag	Lead	Lag	Lead

Result:

Viva Voice Questions:

1. What is meant by ZPF Test?
2. What is Potier reactance? How is it determined by Potier triangle?
3. What is meant by armature reaction reactance?
4. What is the significance of the ASA modification of MMF method?
5. What is air gap line in Potier method

Exp. No.: 09

Date:

DETERMINATION OF X_d & X_q OF SALIENT POLE SYNCHRONOUS MACHINE

Aim:

To determine the value of direct axis reactance (X_d) and quadrature axis reactance (X_q) of the given synchronous machine by conducting slip test.

Apparatus:

S. No.	Name of the Equipment	Range	Type	Quantity
1	3- Φ Variac	415V/(0-470)V	-	1
2	Rheostat	360 Ω /1.2A	WW	1
3	Ammeter	(0-5)A	MI	1
4	Voltmeter	(0-150)V	MI	1
5	Tachometer	(0-10000)rpm	Digital	1
6	Connecting Wires	-	-	Required Some

Circuit Diagram:

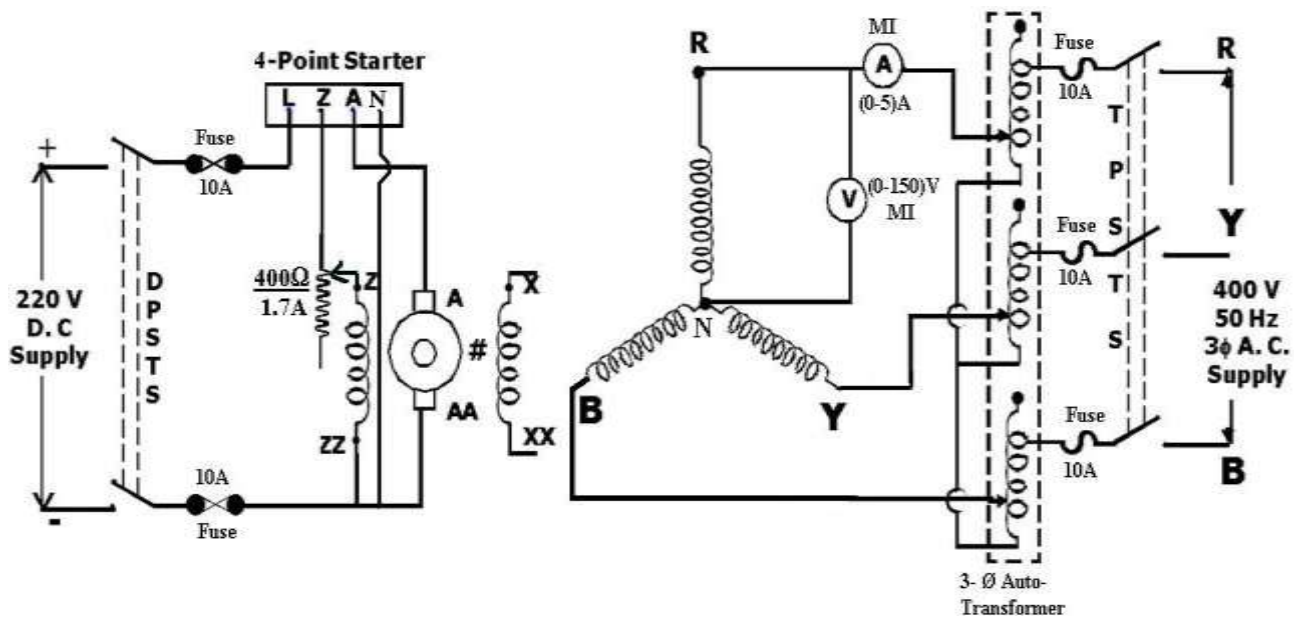

Precautions:

1. Connections must be made tight.
2. Field rheostat must be kept in minimum resistance position.
3. Starter must be in OFF position.

Procedure:

1. Connect the circuit as shown in circuit diagram.
2. Start the D.C Motor with the help of starter.
3. Adjust the field rheostat of the D.C Motor so that it runs slightly below the synchronous speed of synchronous machine.
4. Give A.C Supply to the Alternator with the help of variac so that rated current flows in the synchronous machine.
5. The speed of D.C motor is adjusted such that the points of the meters oscillate between maximum and minimum values.
6. Note down the maximum and minimum values of ammeter and voltmeter and tabulate them.

Tabular Columns:

V_{max} (V)	V_{min} (V)	I_{max} (A)	I_{min} (A)	X_d (Ω)	X_q (Ω)

Formulae:

Direct Axis Synchronous Reactance = $X_d = \frac{V_{max}}{I_{min}} (\Omega)$

Quadrature Axis Synchronous Reactance = $X_q = \frac{V_{min}}{I_{max}} (\Omega)$

Result:

Viva Voce Questions:

1. Define saliency?
2. Why this test is not applicable for cylindrical synchronous machines?
3. What is meant by fictitious reactance of alternator?
4. Define leakage reactance of the alternator?
5. Why the synchronous machines are called double excited machines?
6. What is the maximum possible speed of synchronous machine?
7. What is the difference between X_s , X_a , and X_L ?
8. What are inputs for the synchronous machines?
9. What is reluctance offered by the polar axis when compared to quadrature axis?
10. What type of field winding we can provide on salient pole synchronous machines?

Exp. No.: 10

Date:

V – CURVES AND Δ-CURVES OF A THREE PHASE SYNCHRONOUS MOTOR

Aim:

Conduct an experiment to draw v-curves and Δ-curves of a three-phase synchronous motor.

Apparatus:

Sl.No.	Equipment	Type	Range	Quantity
1.	Voltmeter	MI	(0-300)V	1
2.	Ammeter	MI	(0-10)A	1
3.	Three phase variac	Variable	415V/(0-470)V	1
4.	Wattmeter	MI	300V,10A,UPF	2
5.	Tachometer	DIGITAL	(0-10000)rpm	1
6.	Ammeter	MC	(0-2)A	1
7.	Connecting Wires	-	-	Required Some

Circuit Diagram:

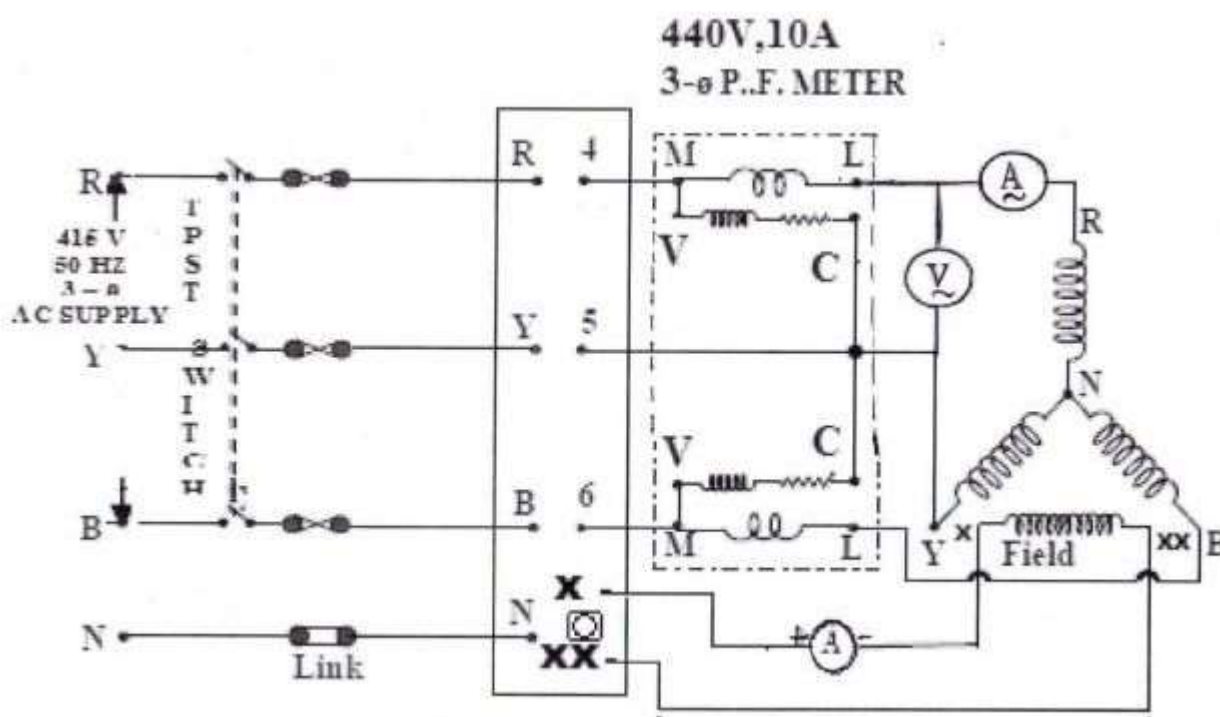

Precautions:

1. Connections must be made tight
2. Meters should be read without parallax error
3. Constant load must be maintained throughout the experiment.

Procedure:

1. Start the synchronous motor by applying rated voltage using an auto transformer.
2. At a constant mechanical load applied on the motor, vary its field excitation in steps to its rated value noting down the corresponding meter readings at each step and tabulate them.
3. Repeat step 2 for some other load.
4. Plot graphs between I_f and I_a (V – curve) and I_f and P. F (\wedge - curves) for the different loads applied.

Calculations:

$$\tan\phi = \frac{\sqrt{3} (W_1 - W_2)}{(W_1 + W_2)}$$

$$\phi = \tan^{-1} \left[\frac{\sqrt{3} (W_1 - W_2)}{(W_1 + W_2)} \right]$$

Power factor = $\cos \phi$

Tabular form:

For load 1 =

I_f (A)	I_a (A)	W_1 (W)	W_2 (W)	$\tan\phi = \frac{\sqrt{3} (W_1 - W_2)}{(W_1 + W_2)}$	ϕ	$\cos\phi$

Model Graph:

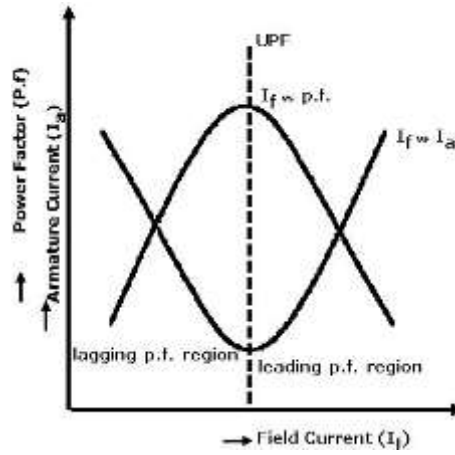

Result:

Viva Voice Questions:

1. What are the difficulties in starting a synchronous motor?
2. What are the commonly employed methods of starting a synchronous motor?
3. What are the applications of synchronous motor?
4. What is synchronous condenser?
5. What do you understand by hunting?
6. Why synchronous motor is not self-starting?
7. Difference between synchronous motor and induction motor?
8. Use of damper winding in synchronous machines
9. What is need of excitation and synchronization in synchronous motor?
10. Explain principle of operation of Synchronous motor.

Exp. No.: 11

Date:

SEPARATION OF NO-LOAD LOSSES OF THREE PHASE INDUCTION MOTOR

AIM:

To separate the no load losses of a 3-phase squirrel cage induction motor as iron losses and mechanical losses.

APPARATUS REQUIRED:

S.No	Name of the apparatus	Type	Range	Quantity
1.	Ammeter	MI	(0-10)A	1
2.	Voltmeter	MI	(0-600)V	1
3.	Wattmeter	LPF	600V,5A	2
4.	3-Φ Auto Transformer		(415/0-470) V	1
5.	Connecting wire			required

NAME PLATE DETAILS:

PRECAUTIONS:

- (1) The autotransformer should be kept in minimum voltage position.
- (2) The motor should not be loaded throughout the experiment.

Circuit diagram

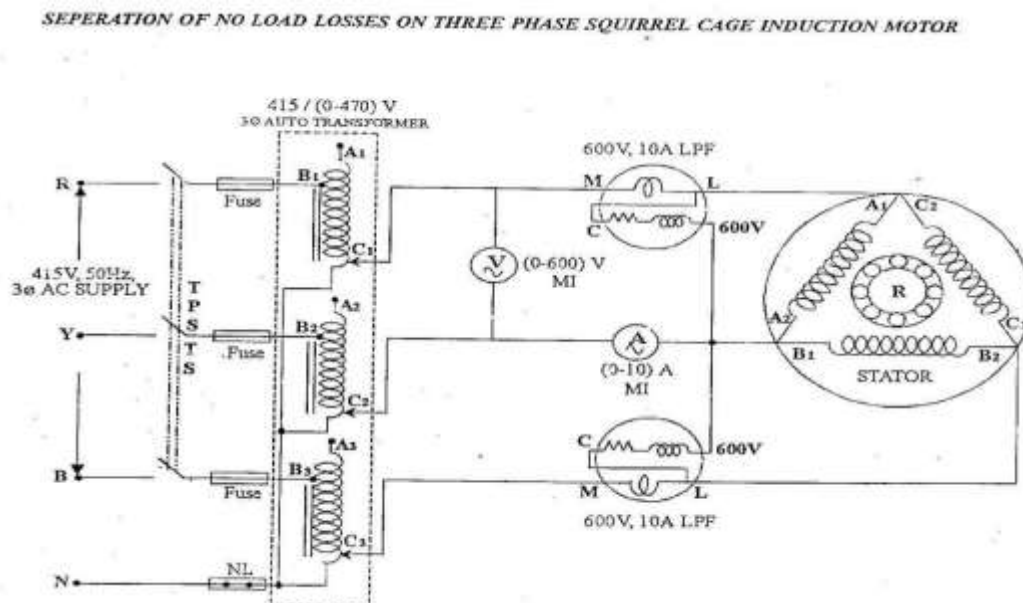

PROCEDURE:

1. Connect the circuit as per the circuit diagram.
2. Apply three phase supply by varying the autotransformer and start the motor till rated speed is attained and note down the the input power, voltage and current.
3. Repeat the same procedure and tabulate the reading.
4. Find the stator copper loss and constant loss by respective formulas.
5. Draw the graph to find the mechanical losses
6. Obtain the core loss by separating the mechanical loss from constant losses.

GRAPH:

The graph drawn between constant losses(watts) and input voltage(volts).

AC MACHINES LAB

TABULAR COLUMN:

TABULATION FOR SEPARATION OF NO LOAD LOSS ON THREE PHASE SQUIRREL CAGE INDUCTION MOTOR

S.No	No Load Voltage (V ₀)	No Load Current (I ₀)	No Load input power				Total input power. (W = W ₁ + W ₂)	Stator Copper loss (3I ₀ ² R _s)	Constant Loss per phase (W _c = W - I ₀ ² R _s)/3	Core Loss per phase (W _i = W _c - W _m)
			W ₁		W ₂					
	Volts	Amps	Observed	Actual	Observed		Watts	Watts	Watts	Watts

MODEL CALCULATIONS:

1. Input power(W) =(W₁+W₂) in watts
2. Stator copper loss =3I₀²R_s in watts
3. Constant loss/phase (W_c)= (W-3I₀²R_s)/3 in watts
- 4 Core loss/phase (W_i)= (constant loss/phase)-mechanical loss

Result:

Exp. No.: 12

Date:

SYNCHRONIZATION OF ALTERNATOR WITH INFINITE BUS BY BRIGHT LAMP METHOD.

AIM: - To Study the Synchronization of an Alternator with Infinite Bus by Bright Lamp Method.

APPARATUS: -

3 phase Alternator: - 1 KW, 4.2A, 1500 rpm, 3 phase, 440 V
DC shunt motor - 1.5 Kw , shunt , 8 A , 220V , 1500 rpm , self excited . Voltmeter 0-600 V AC
Lamp bank, rheostats, 400 ohms - 1.7 A, A knife switches, connecting wires.

CIRCUIT DIAGRAM: -

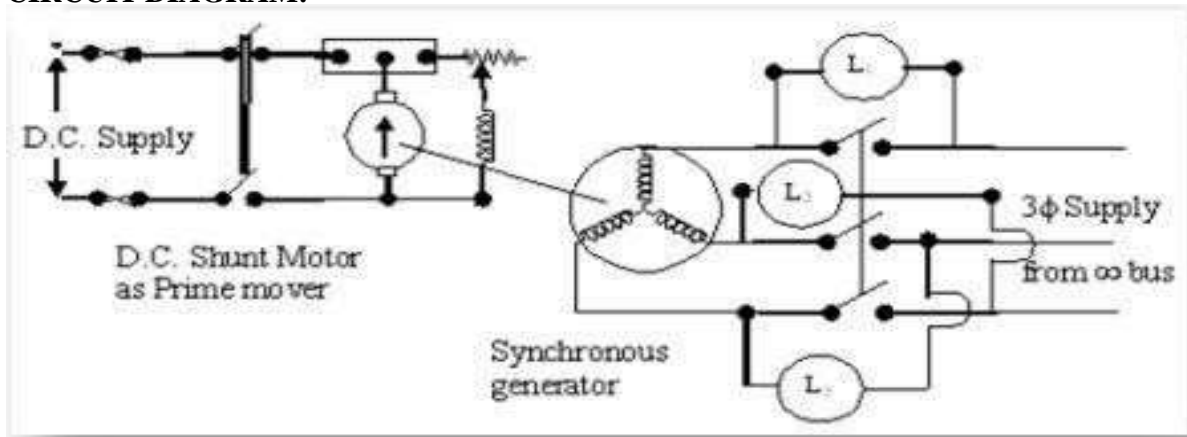

THEORY:

Following conditions must be satisfied for the synchronization of alternator with infinite bus.

- 1) The terminal voltage of the incoming alternator must be equal to the bus voltage.
- 2) The frequency of incoming alternator must be equal to the bus frequency.
- 3) The voltage of incoming alternator and bus must be in the same phase with respect to the external load.

A voltmeter can be used to check the voltage of bus and incoming alternator

For frequency and phase lamps are used.

Following are the advantages of parallel operation of alternators.

- 1) Repairs and maintenance of individual generating unit can be done by keeping the continuity of supply.
- 2) Economy
- 3) Additional sets can be connected in parallel to meet the increasing de

PROCEDURE:

- 1) Connect the circuit as shown in the diagram.
- 2) Keep all the switches S_1 , S_2 , SL_1 , SL_2 , and SL_3 in open position and put on the DC supply.
- 3) Start the DC motor and bring the speed very near to synchronous speed of the alternator.
- 4) Put on AC supply and measure its voltage by keeping the position of switch S_2 on line side.
- 5) Now keep the switch S_2 on alternator side and adjust its field current such that it gives voltage equal to the line voltage.
- 6) Now put on the switches SL_1 , SL_2 , SL_3 watch the changes in the glow of three sets of lamps. At one instant two will be equally bright while the third set will be fully dark. . Then the set which is fully dark slowly starts becoming bright and one set from the two which were bright starts dimming. A position will come when this set will become fully dark while other two will be equally bright.
- 7) Make small adjustment in speed and excitation of alternator to get long dark and bright periods.
- 8) At an instant when pair IR -IR is dark and IB-IB are equally bright, close switch S-1 to synchronize the alternator to bus. Observe the reading of ammeter which should be minimum.

RESULT: