

CONTROL SYSTEMS

(20A02502T)



PREPARED BY
P.I.D.T.BALADURAIKANNAN
Associate Professor
Department Electrical & Electronics Engineering
VEMU IT

UNIT I

CONTROL SYSTEMS CONCEPTS

- **Control System Definition**
 - Consists of **subsystems** and **processes/plants** assembled for the purpose of controlling the **outputs** of the processes.
 - Provides an **output** or response for a given **input** or stimulus
 - A control system is an interconnection of components forming a system configuration that would provide a desired **output** in response to **input** signals.



Basic Block Diagram of Control System

System Configurations: i) Open-loop Control System(OLCS)

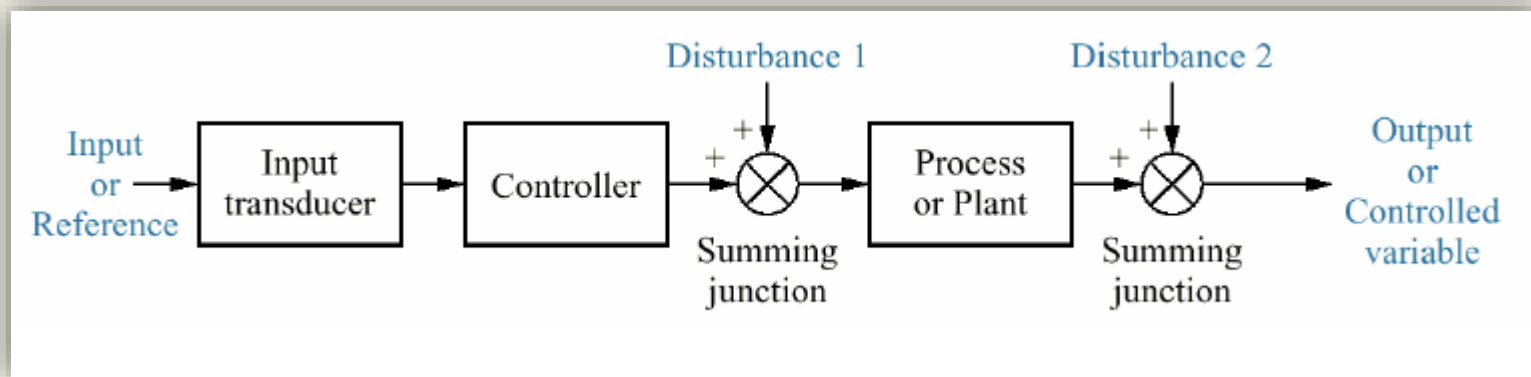

- The output signal of OLCS is not fed back to influence the control action
- The control action of an OLCS depends only on the input signal
- OLCS are not capable of filtering disturbances or noise
- OLCS are suitable when input signal for satisfactory system performance can be estimated/approximated and does not change
- **Advantages** of OLCS are that its structure is simple compared to a closed loop control system and is cheaper to build.

ii) Closed-loop Control System (CLCS)

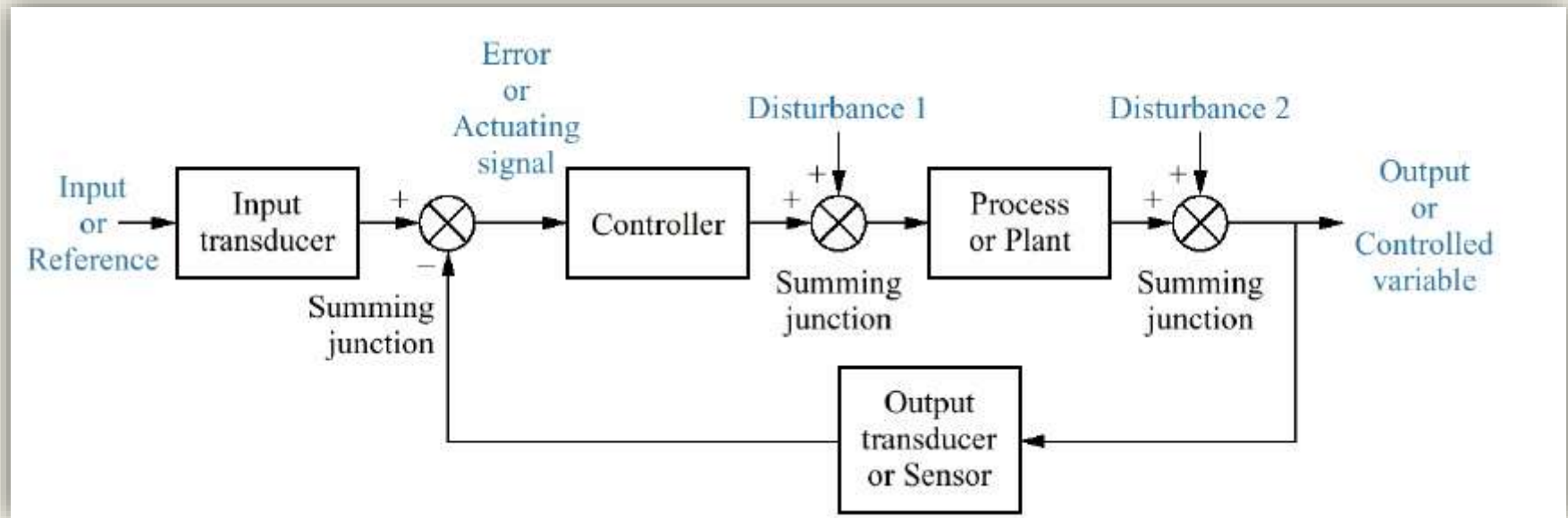

- The output signal of a CLCS is fed back to influence the control action and improve the overall system performance
- **Examples:** robot arms, velocity control systems, temperature control systems
- However, in practical, a combination of both OLCS and CLCS is normally used. For example, washing machine: the process of filling up the tank with water is a CLCS operation, while the process of washing and rinsing is an OLCS operation

OLCS vs CLCS

Type of System	Advantages	Disadvantages	Examples
OLCS	<ul style="list-style-type: none"> • Simple construction and ease of maintenance. • Less expensive than a corresponding closed-loop control system • There is no stability problem • Convenient when output is hard to measure or measuring the output precisely is economically not feasible 	<ul style="list-style-type: none"> • The system response very sensitive to external disturbance and internal variations in system parameters. • Recalibration is necessary from time to time in order to maintain the required quality in the output 	<ul style="list-style-type: none"> • Toaster • Rice cooker • Electric fan • Photocopy machine
CLCS	<ul style="list-style-type: none"> • insensitive to external disturbance and internal variations in system parameters. • Possible to use relatively inaccurate and inexpensive components to obtain the accurate control of a given plant. • Better control of transient & steady-state response • Increased accuracy • Increased ability to reproduce output with varied input 	<ul style="list-style-type: none"> • Risk instability • Complexity in analysis and implementation and expensive 	<ul style="list-style-type: none"> • Positioning CS (robot arms) • Velocity CS (vehicles cruise system) • Temperature CS (Air-conditioner)

block diagram: reduction example

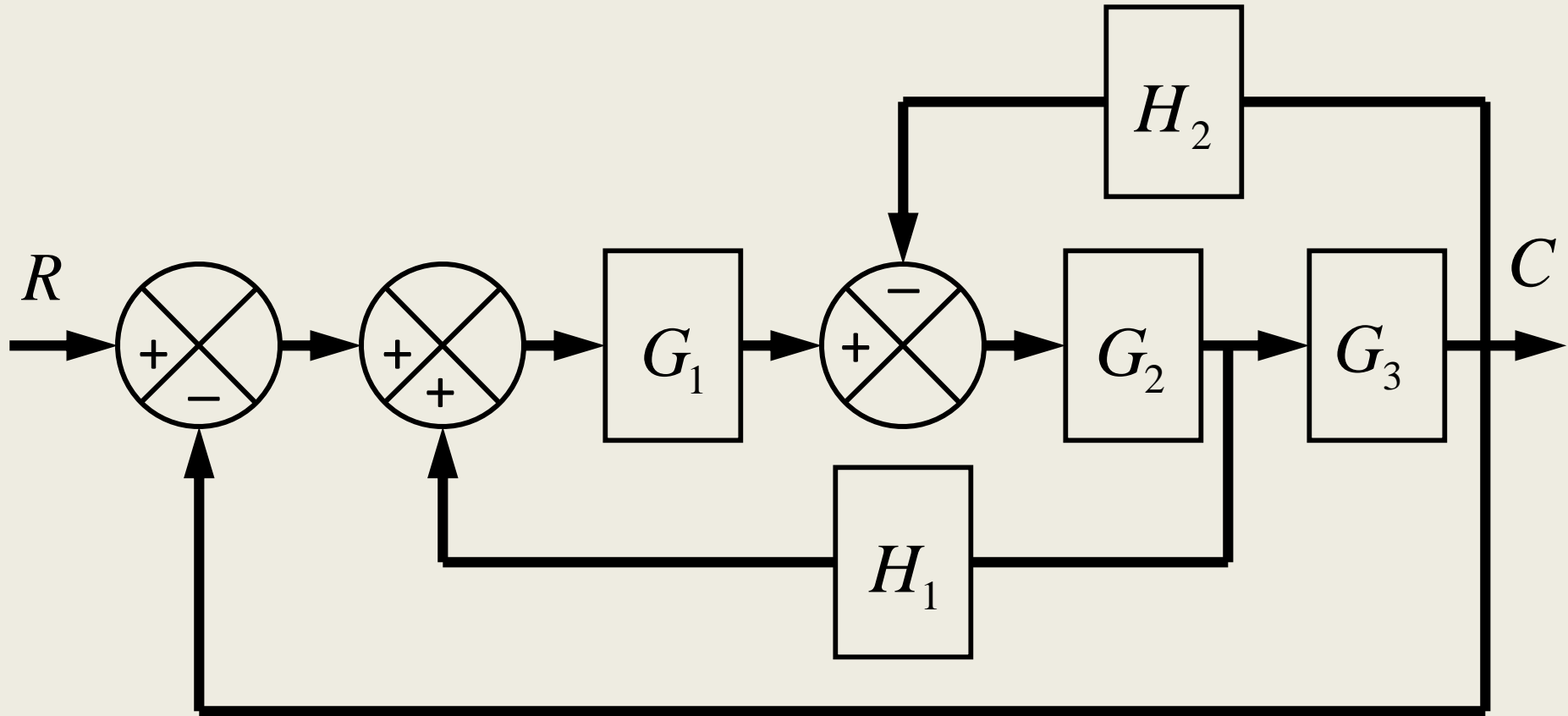

block diagram: reduction example

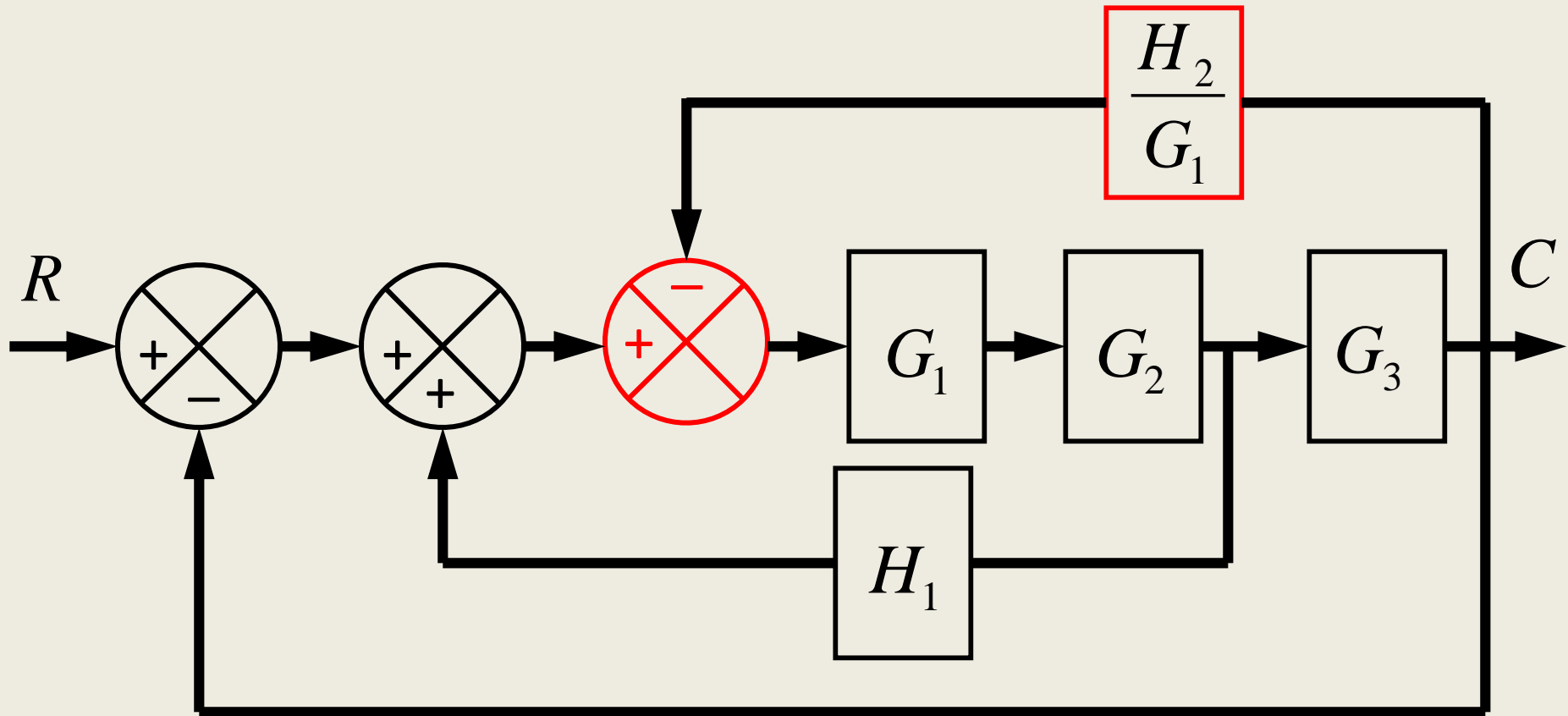

block diagram: reduction example

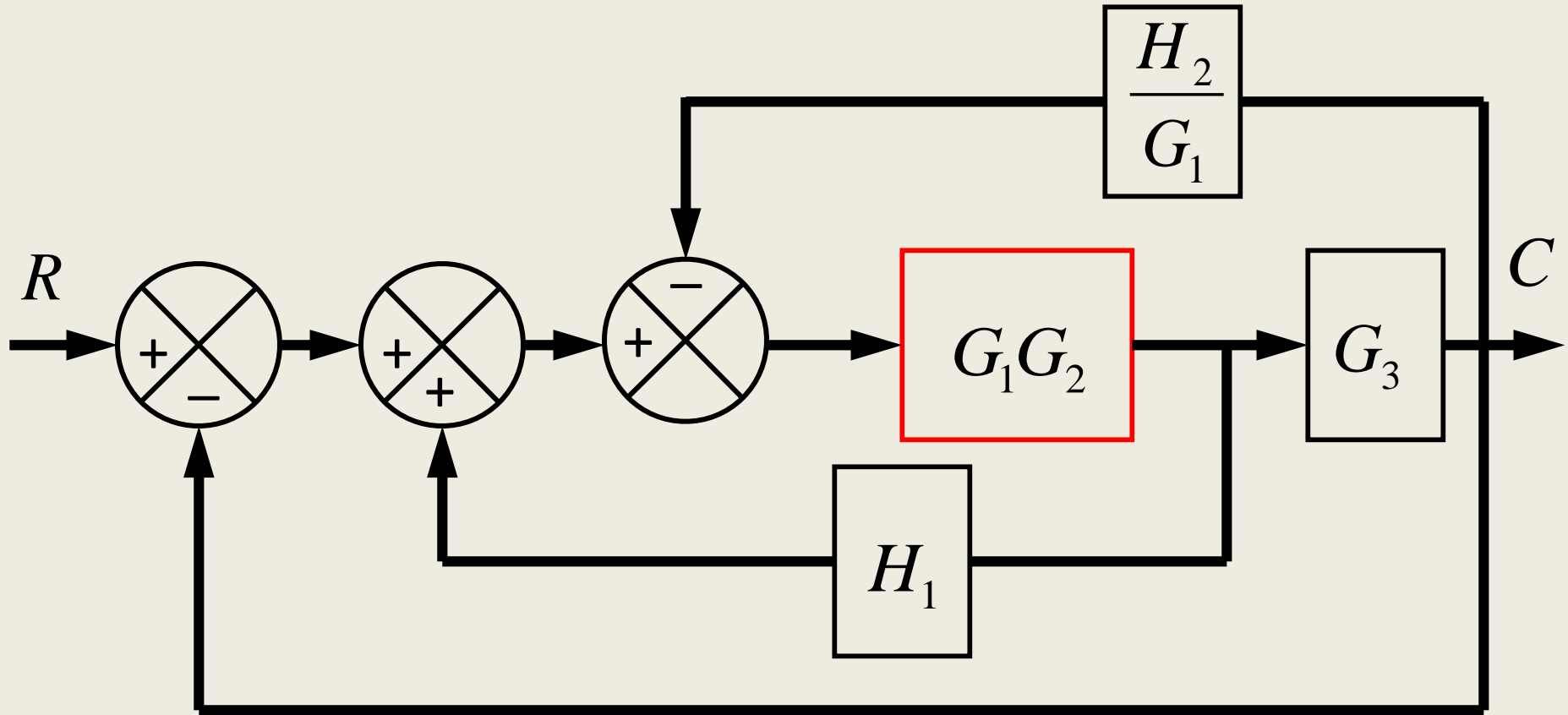

block diagram: reduction example

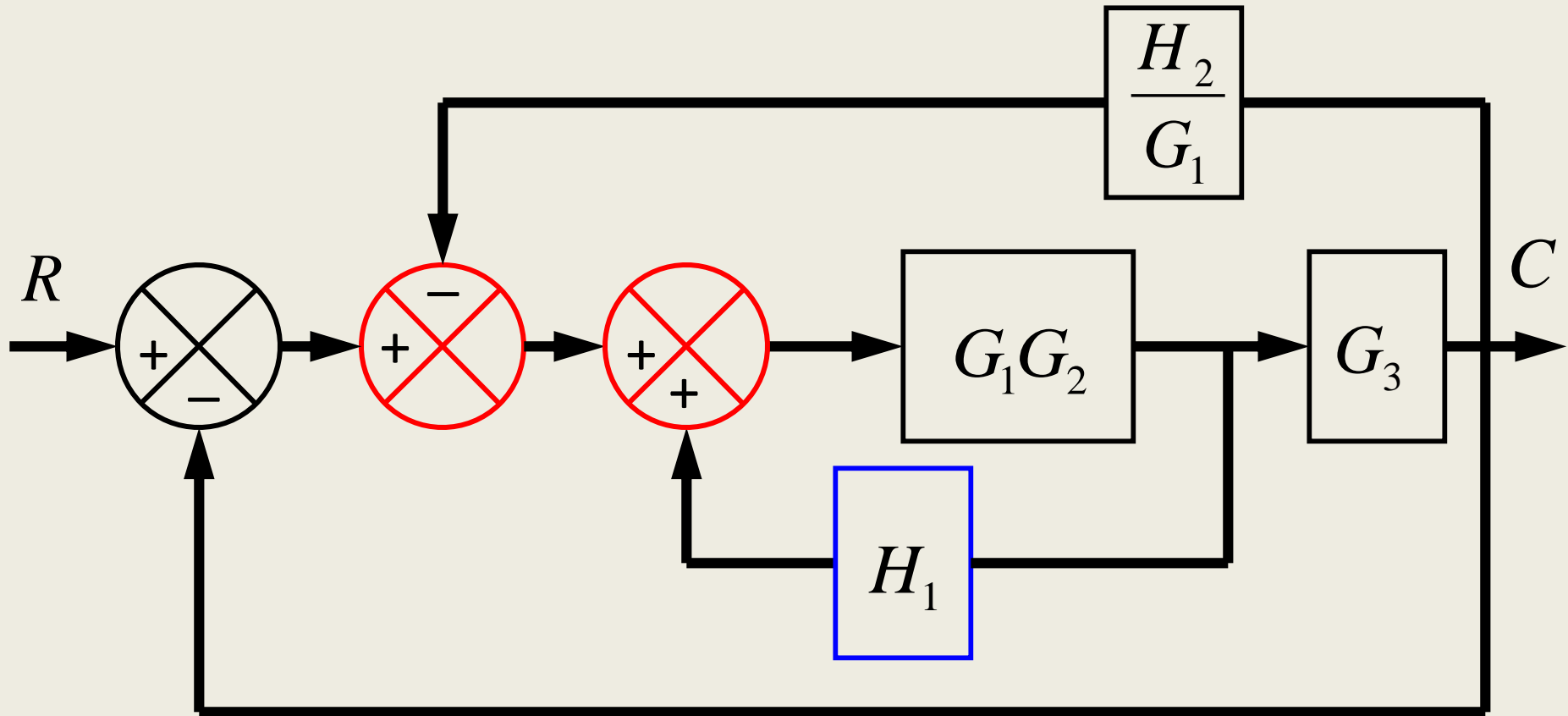

block diagram: reduction example

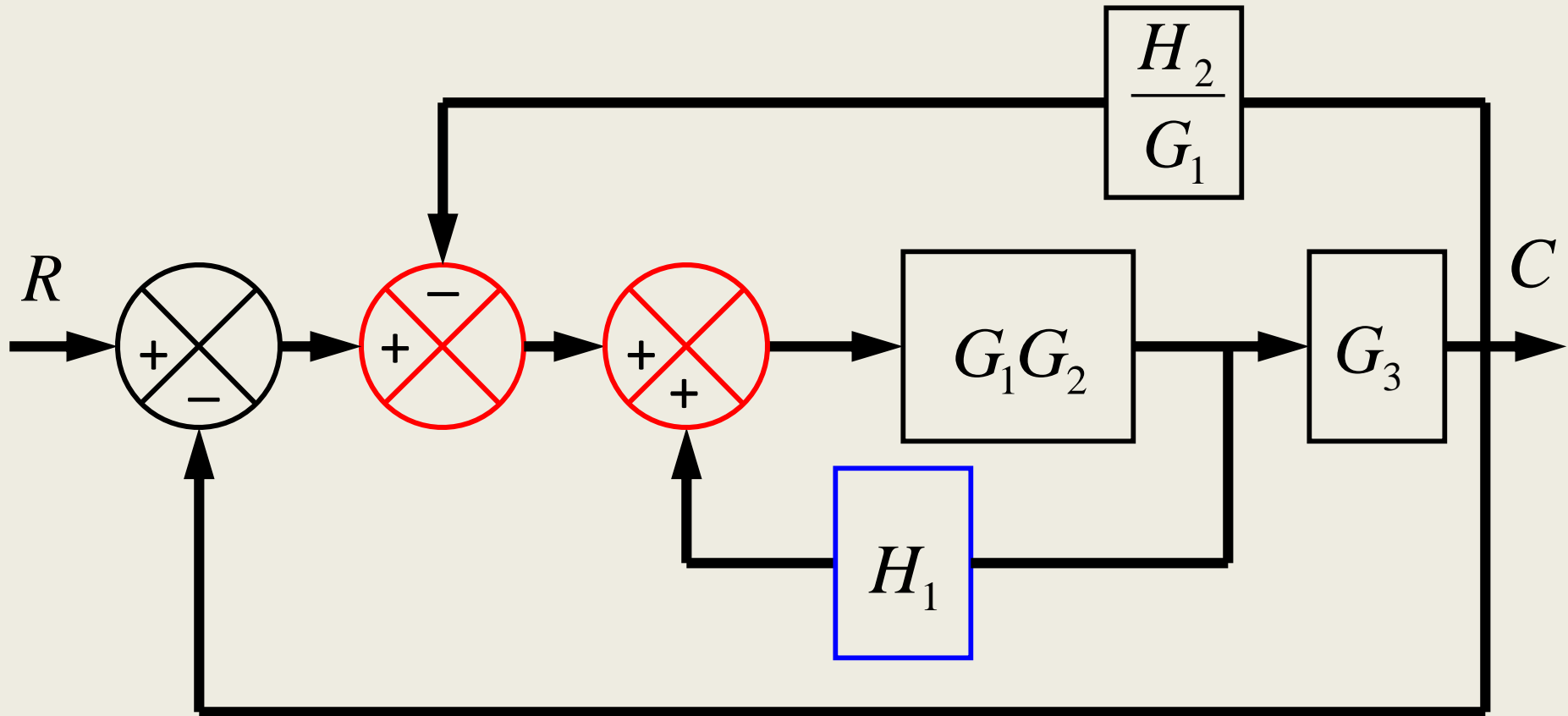

block diagram: reduction example

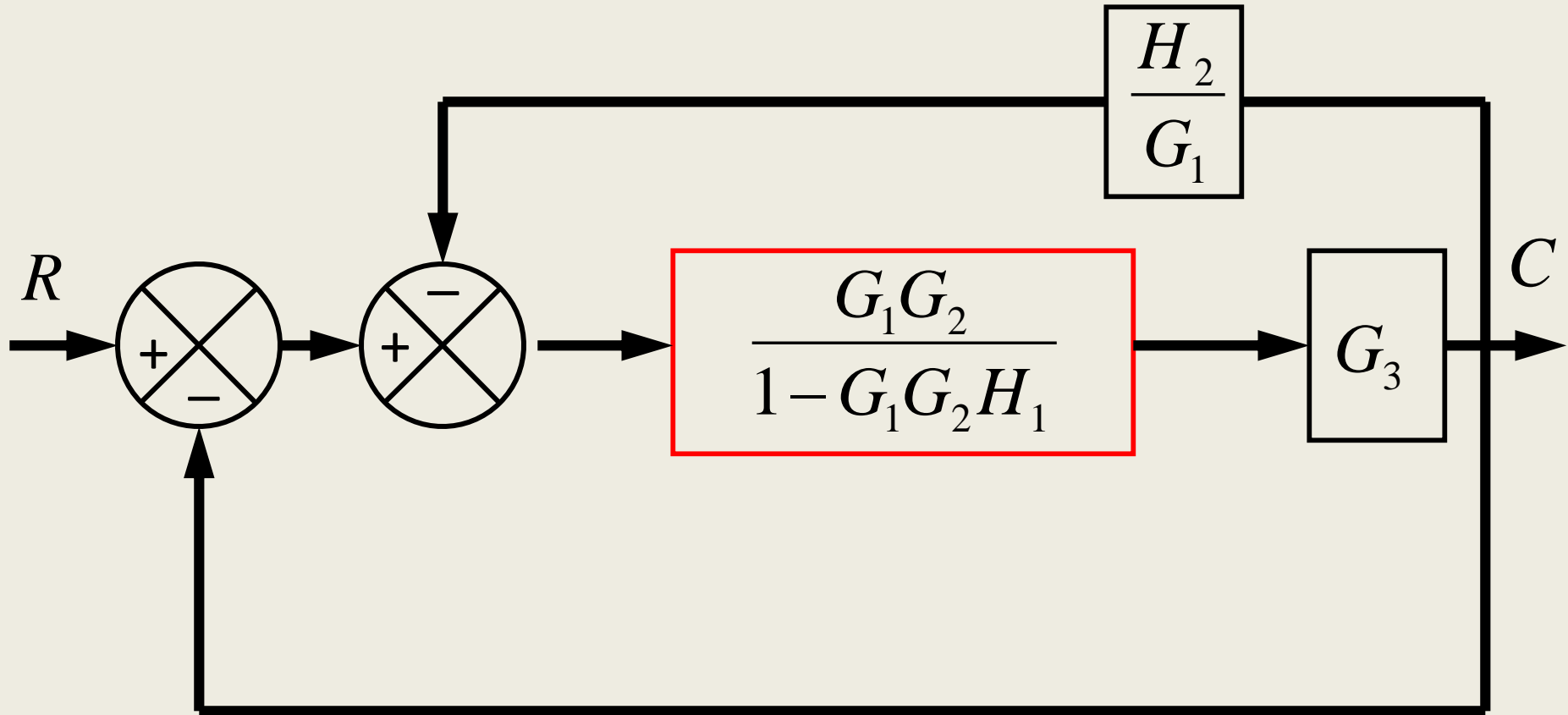

block diagram: reduction example

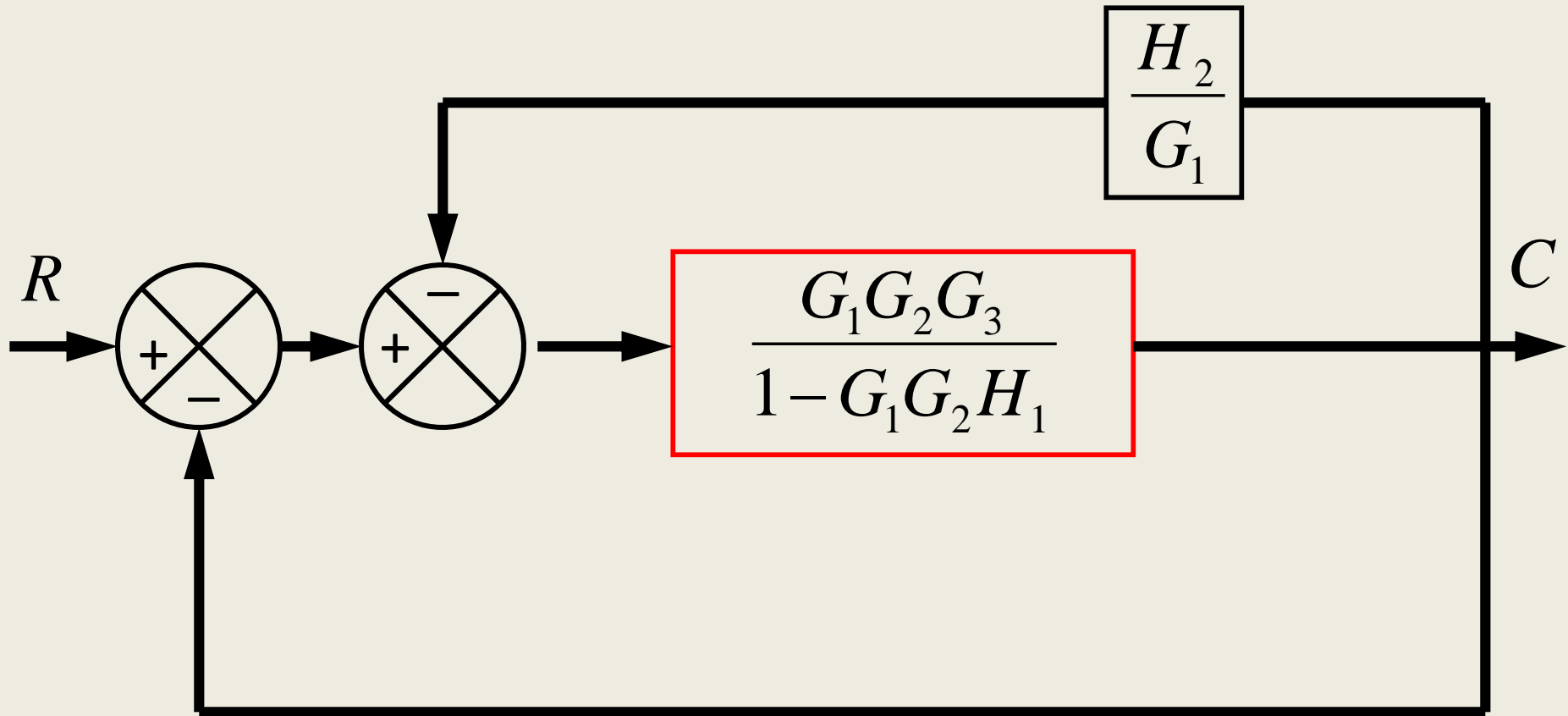

block diagram: reduction example

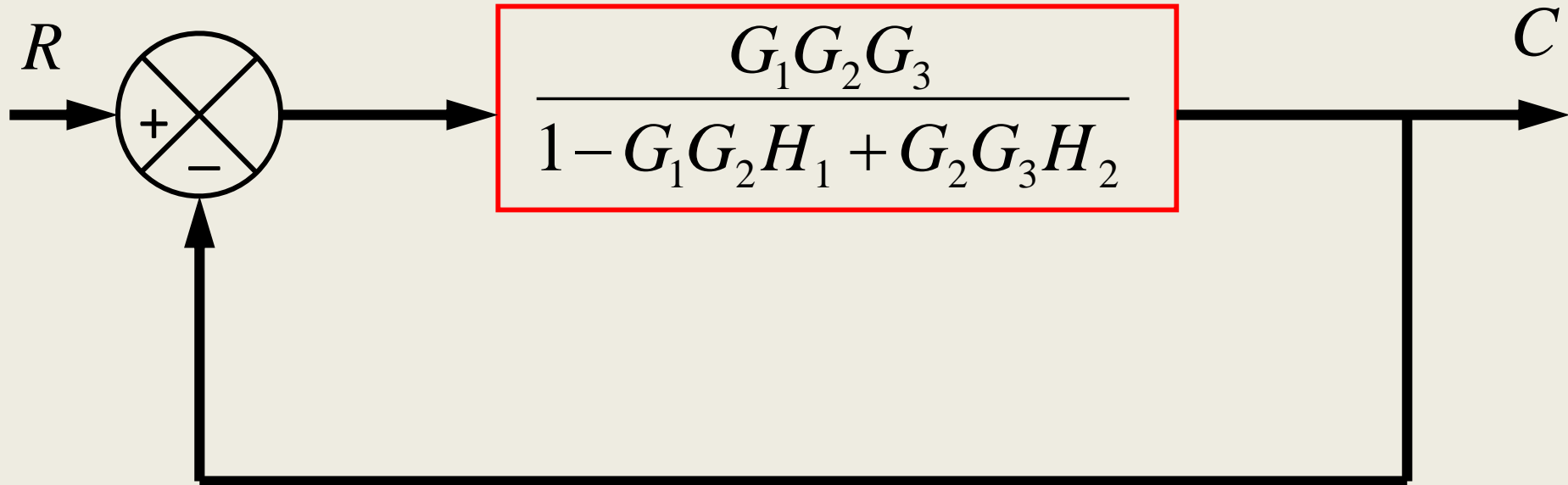

block diagram: reduction example

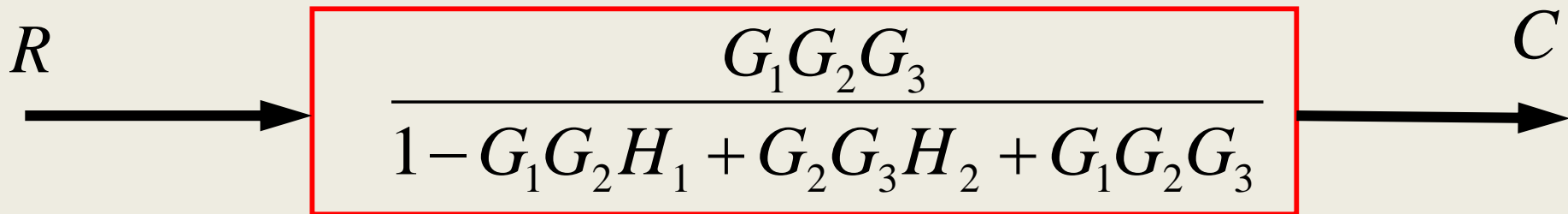

SIGNAL FLOW GRAPH

- Alternative method to block diagram representation, developed by **S.J.Mason**.
- Advantage: the availability of a flow graph gain formula, also called Mason's gain formula.
- A signal-flow graph consists of a network in which nodes are connected by directed branches.
- It depicts the flow of signals from one point of a system to another and gives the relationships among the signals. Note that the signal flows in only one direction.

Definitions

- **Node** - a point representing a signal or variable.
- **Branch** – unidirectional line segment joining two nodes.
- **Path** – a branch or a continuous sequence of branches that can be traversed from one node to another node.
- **Loop** – a closed path that originates and terminates on the same node and along the path no node is met twice.
- **Nontouching loops** – two loops are said to be nontouching if they do not have a common node.

Mason's gain formula

The linear dependence T_{ij} between the independent variable x_i (also called the input variable) and a dependent variable x_j is

$$T_{ij} = \frac{\sum_k P_{ijk} \Delta_{ijk}}{\Delta},$$

P_{ijk} = k th path from variable x_i to variable x_j ,

Δ = determinant of the graph,

Δ_{ijk} = cofactor of the path P_{ijk} ,

and the summation is taken over all possible k paths from x_i to x_j . The cofactor Δ_{ijk} is the determinant with the loops touching the k th path removed. The determinant Δ is

$$\Delta = 1 - \sum_{n=1}^N L_n + \sum_{m=1, q=1}^{M, Q} L_m L_q - \sum L_r L_s L_t + \dots,$$

where L_q equals the value of the q th loop transmittance. Therefore the rule for evaluating Δ in terms of loops $L_1, L_2, L_3, \dots, L_N$ is

$\Delta = 1 -$ (sum of all different loop gains)

+ (sum of the gain products of all combinations of two nontouching loops)

- (sum of the gain products of all combinations of three nontouching loops)

+ \dots .

$$T_{ij} = \frac{\sum_k P_{ijk} \Delta_{ijk}}{\Delta},$$

P_{ijk} = k th path from variable x_i to variable x_j .

Δ = determinant of the graph.

Δ_{ijk} = cofactor of the path P_{ijk} .

and the summation is taken over all possible k paths from x_i to x_j . The cofactor Δ_{ijk} is the determinant with the loops touching the k th path removed. The determinant Δ is

$$\Delta = 1 - \sum_{n=1}^N L_n + \sum_{m=1, q=1}^{M, Q} L_m L_q - \sum L_r L_s L_t + \dots,$$

where L_q equals the value of the q th loop transmittance. Therefore the rule for evaluating Δ in terms of loops $L_1, L_2, L_3, \dots, L_N$ is

$$\begin{aligned} \Delta = & 1 - (\text{sum of all different loop gains}) \\ & + (\text{sum of the gain products of all combinations of two nontouching loops}) \\ & - (\text{sum of the gain products of all combinations of three nontouching loops}) \\ & + \dots, \end{aligned}$$

Dr. Ibrahim Al-Abbas

Write the gain formula in a simplified form:

$$T = \frac{\sum_k P_k \Delta_k}{\Delta}$$

Systematic approach:

1. Calculate forward path transfer function P_k for each forward path k
2. Calculate all loop transfer functions
3. Consider nontouching loops 2 at a time
4. Consider nontouching loops 3 at a time
5. etc
6. Calculate Δ from steps 2,3,4 and 5
7. Calculate Δ_k as portion of Δ not touching forward path k

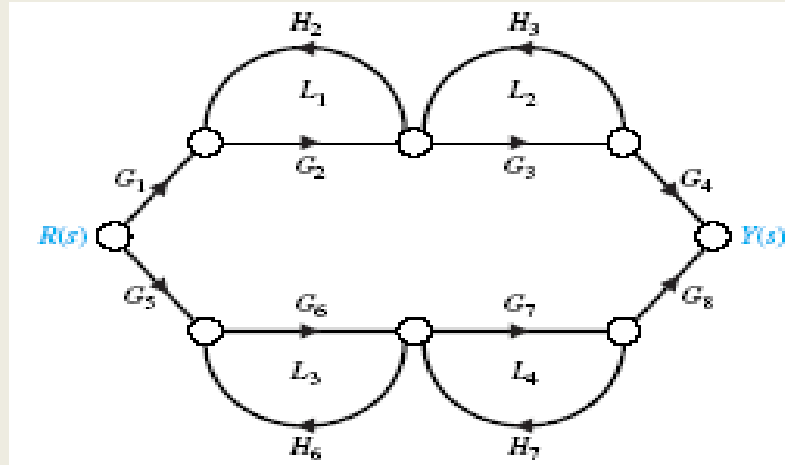

1. Calculate forward path transfer function P_k for each forward path k .

$$P_1 = G_1 G_2 G_3 G_4 \text{ (path 1)} \quad \text{and} \quad P_2 = G_5 G_6 G_7 G_8 \text{ (path 2)}$$

2. Calculate all loop TF's.

$$L_1 = G_2 H_2, \quad L_2 = H_3 G_3, \quad L_3 = G_6 H_6, \quad L_4 = G_7 H_7$$

3. Consider nontouching loops 2 at a time.

Loops L1 and L2 do not touch Loops L3 and L4

4. Consider nontouching loops 3 at a time.

None.

5. Calculate Δ from steps 2,3,4.

$$\Delta = 1 - (L_1 + L_2 + L_3 + L_4) + (L_1L_3 + L_1L_4 + L_2L_3 + L_2L_4)$$

6. Calculate Δ_k as portion of Δ not touching forward path k .

$$\Delta_1 = 1 - (L_3 + L_4) \quad \text{and} \quad \Delta_2 = 1 - (L_1 + L_2)$$

The TF of the system is

$$\frac{Y(s)}{R(s)} = T(s) = \frac{P_1\Delta_1 + P_2\Delta_2}{\Delta}$$

UNIT II TIME RESPONSE ANALYSIS

- We have already discussed the affect of location of poles and zeros on the transient response of 1st order systems.
- Compared to the simplicity of a first-order system, a second-order system exhibits a wide range of responses that must be analyzed and described.
- Varying a first-order system's parameter (T, K) simply changes the speed and offset of the response
- Whereas, changes in the parameters of a second-order system can change the *form* of the response.
- A second-order system can display characteristics much like a first-order system or, depending on component values, display damped or *pure oscillations* for its *transient response*.

Introduction

- A general second-order system is characterized by the following transfer function.

$$\frac{C(s)}{R(s)} = \frac{\omega_n^2}{s^2 + 2\zeta\omega_n s + \omega_n^2}$$

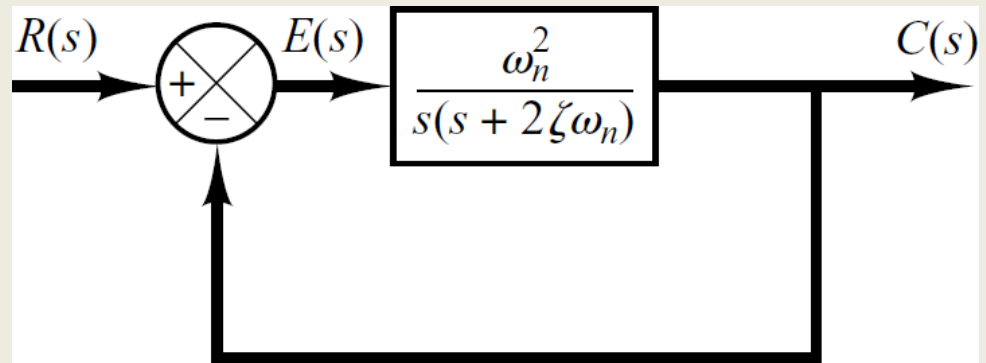

ω_n \longrightarrow **un-damped natural frequency** of the second order system, which is the frequency of oscillation of the system without damping.

ζ \longrightarrow **damping ratio** of the second order system, which is a measure of the degree of resistance to change in the system output.

$$\frac{C(s)}{R(s)} = \frac{\omega_n^2}{s^2 + 2\zeta\omega_n s + \omega_n^2}$$

- Two poles of the system are

$$-\omega_n\zeta + \omega_n\sqrt{\zeta^2 - 1}$$

$$-\omega_n\zeta - \omega_n\sqrt{\zeta^2 - 1}$$

$$-\omega_n \zeta + \omega_n \sqrt{\zeta^2 - 1}$$

$$-\omega_n \zeta - \omega_n \sqrt{\zeta^2 - 1}$$

- According the value of ζ , a second-order system can be set into one of the four categories:

1. Overdamped - when the system has two real distinct poles ($\zeta > 1$).

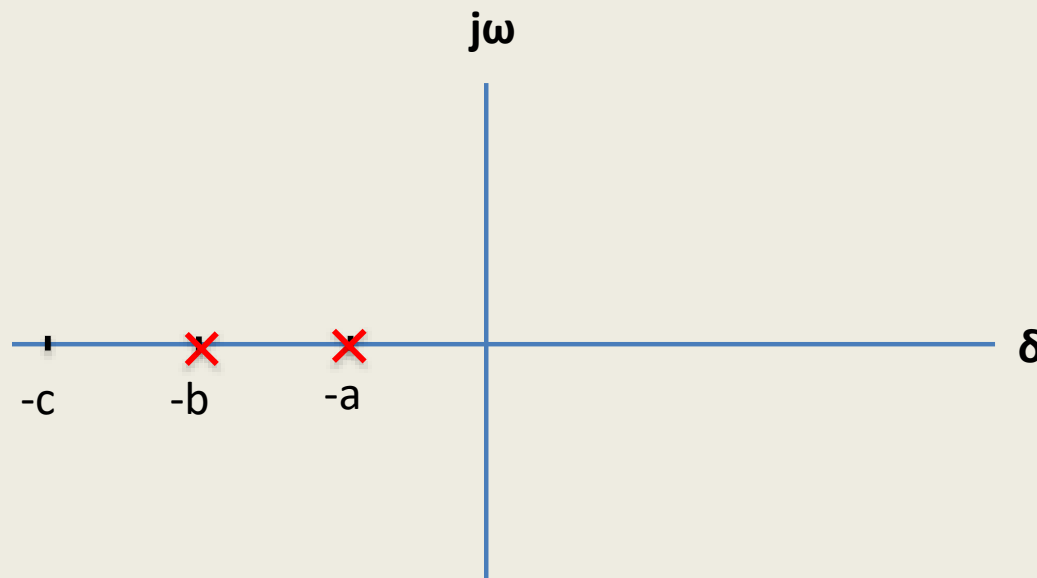

$$-\omega_n \zeta + \omega_n \sqrt{\zeta^2 - 1}$$

$$-\omega_n \zeta - \omega_n \sqrt{\zeta^2 - 1}$$

- According the value of ζ , a second-order system can be set into one of the four categories:

2. *Underdamped* - when the system has two complex conjugate poles ($0 < \zeta < 1$)

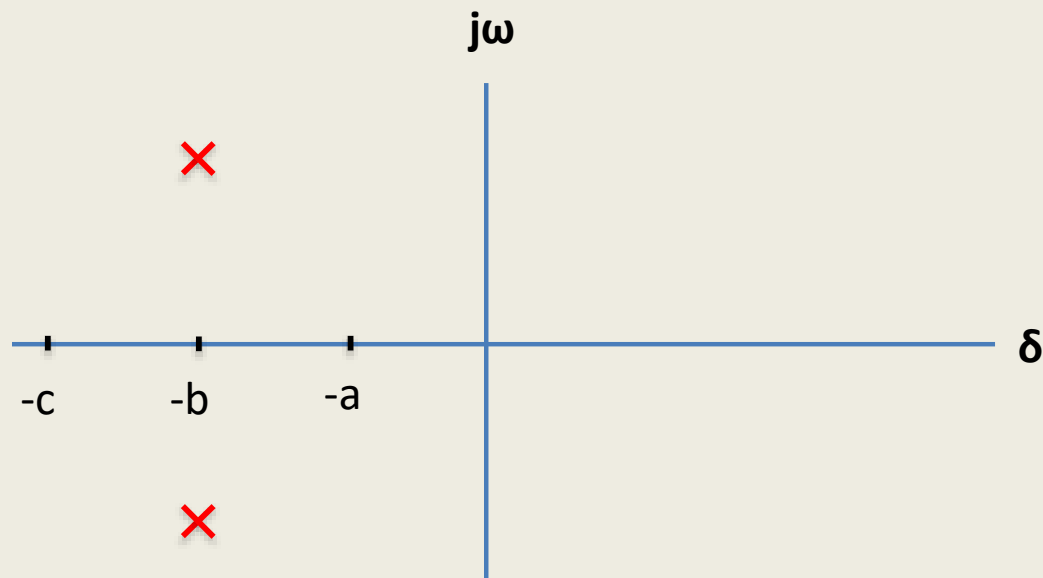

$$-\omega_n \zeta + \omega_n \sqrt{\zeta^2 - 1}$$

$$-\omega_n \zeta - \omega_n \sqrt{\zeta^2 - 1}$$

- According the value of ζ , a second-order system can be set into one of the four categories:

3. *Undamped* - when the system has two imaginary poles ($\zeta = 0$).

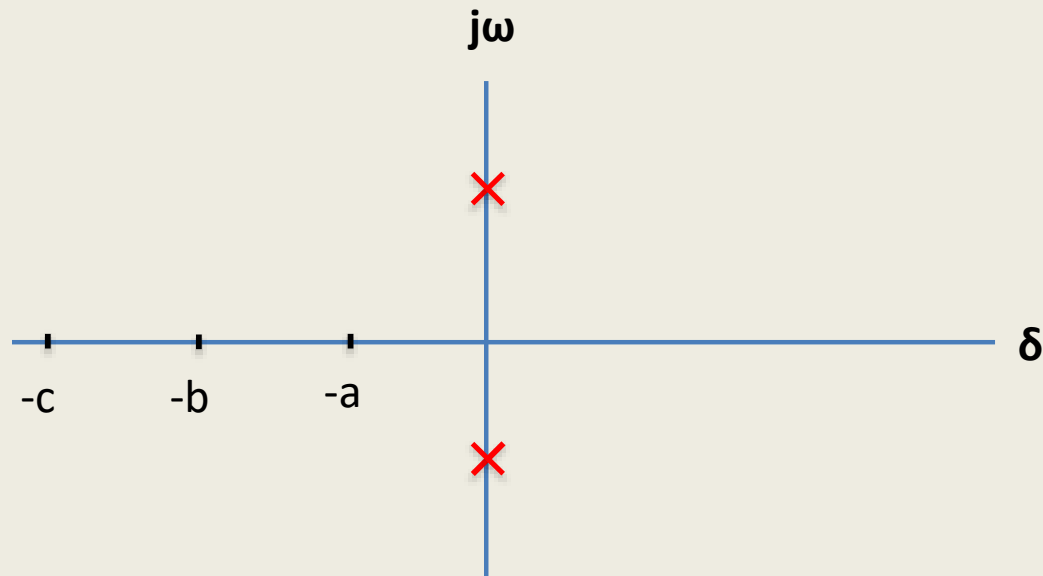

$$-\omega_n \zeta + \omega_n \sqrt{\zeta^2 - 1}$$

$$-\omega_n \zeta - \omega_n \sqrt{\zeta^2 - 1}$$

- According the value of ζ , a second-order system can be set into one of the four categories:

4. *Critically damped* - when the system has two real but equal poles ($\zeta = 1$).

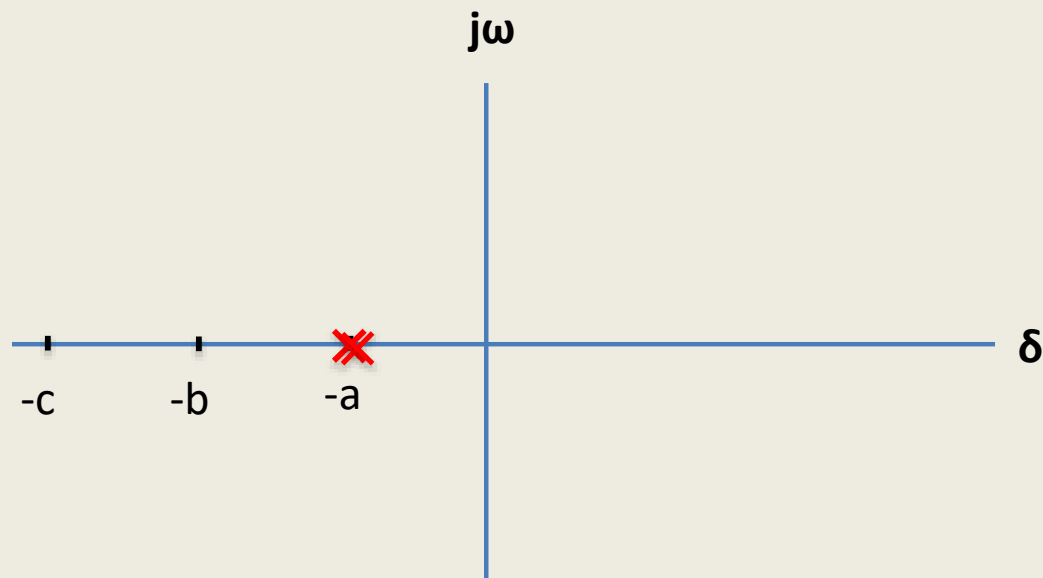

Time-Domain Specification

For $0 < \zeta < 1$ and $\omega_n > 0$, the 2nd order system's response due to a unit step input looks like

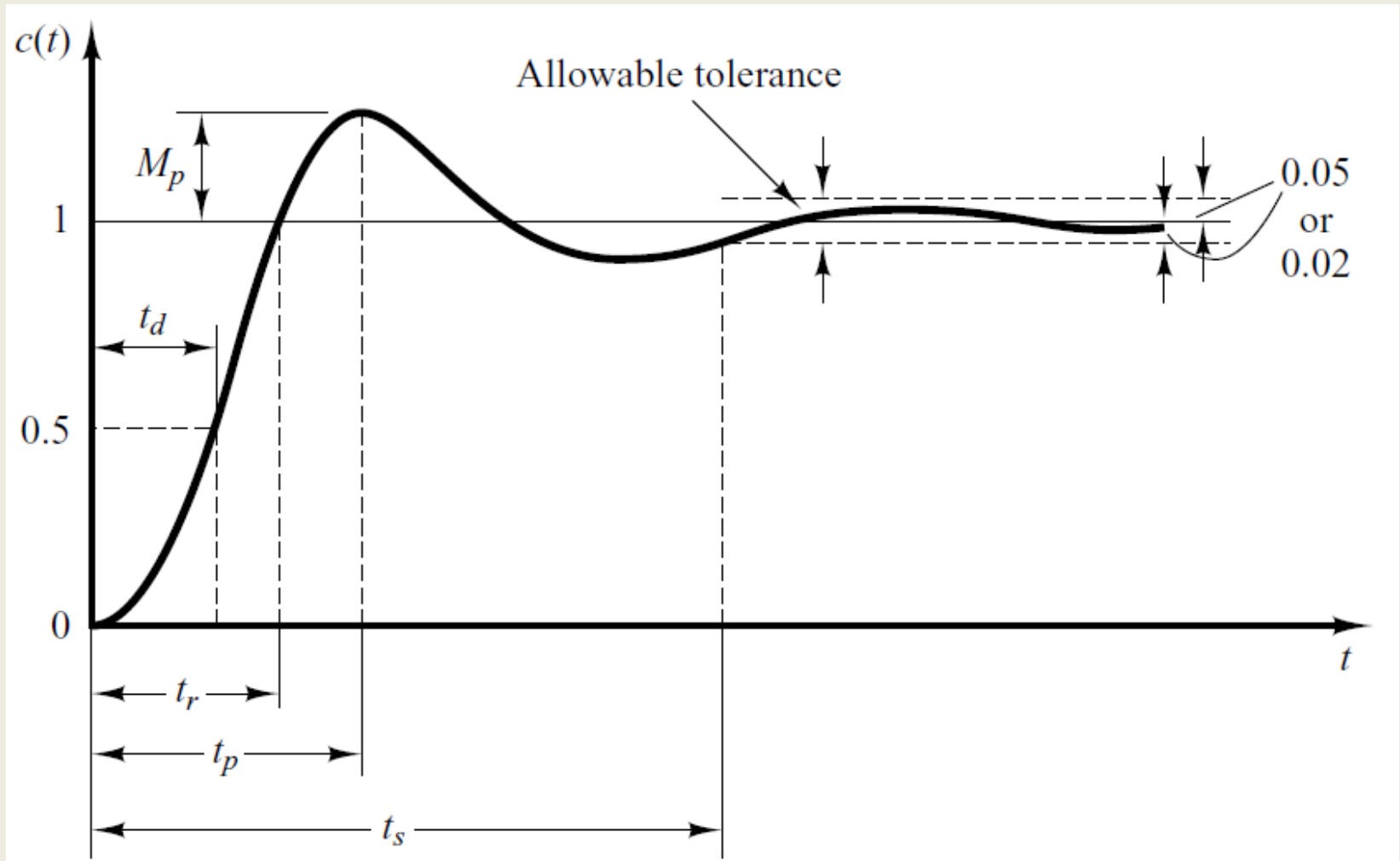

Step Response of underdamped System

$$\frac{C(s)}{R(s)} = \frac{\omega_n^2}{s^2 + 2\zeta\omega_n s + \omega_n^2} \xrightarrow{\text{Step Response}} C(s) = \frac{\omega_n^2}{s(s^2 + 2\zeta\omega_n s + \omega_n^2)}$$

- The partial fraction expansion of above equation is given as

$$C(s) = \frac{1}{s} - \frac{s + 2\zeta\omega_n}{s^2 + 2\zeta\omega_n s + \omega_n^2}$$

$$C(s) = \frac{1}{s} - \frac{s + 2\zeta\omega_n}{s^2 + 2\zeta\omega_n s + \zeta^2\omega_n^2 + \omega_n^2 - \zeta^2\omega_n^2}$$

$$C(s) = \frac{1}{s} - \frac{s + 2\zeta\omega_n}{(s + \zeta\omega_n)^2 + \omega_n^2(1 - \zeta^2)}$$

Step Response of underdamped System

$$C(s) = \frac{1}{s} - \frac{s + 2\zeta\omega_n}{(s + \zeta\omega_n)^2 + \omega_n^2(1 - \zeta^2)}$$

- Above equation can be written as

$$C(s) = \frac{1}{s} - \frac{s + 2\zeta\omega_n}{(s + \zeta\omega_n)^2 + \omega_d^2}$$

- Where $\omega_d = \omega_n \sqrt{1 - \zeta^2}$, is the frequency of transient oscillations and is called **damped natural frequency**.
- The inverse Laplace transform of above equation can be obtained easily if **C(s)** is written in the following form:

$$C(s) = \frac{1}{s} - \frac{s + \zeta\omega_n}{(s + \zeta\omega_n)^2 + \omega_d^2} - \frac{\zeta\omega_n}{(s + \zeta\omega_n)^2 + \omega_d^2}$$

Step Response of underdamped System

$$C(s) = \frac{1}{s} - \frac{s + \zeta\omega_n}{(s + \zeta\omega_n)^2 + \omega_d^2} - \frac{\zeta\omega_n}{(s + \zeta\omega_n)^2 + \omega_d^2}$$

$$C(s) = \frac{1}{s} - \frac{s + \zeta\omega_n}{(s + \zeta\omega_n)^2 + \omega_d^2} - \frac{\frac{\zeta}{\sqrt{1-\zeta^2}}\omega_n\sqrt{1-\zeta^2}}{(s + \zeta\omega_n)^2 + \omega_d^2}$$

$$C(s) = \frac{1}{s} - \frac{s + \zeta\omega_n}{(s + \zeta\omega_n)^2 + \omega_d^2} - \frac{\zeta}{\sqrt{1-\zeta^2}} \frac{\omega_d}{(s + \zeta\omega_n)^2 + \omega_d^2}$$

$$c(t) = 1 - e^{-\zeta\omega_n t} \cos\omega_d t - \frac{\zeta}{\sqrt{1-\zeta^2}} e^{-\zeta\omega_n t} \sin\omega_d t$$

Step Response of underdamped System

$$c(t) = 1 - e^{-\zeta\omega_n t} \cos\omega_d t - \frac{\zeta}{\sqrt{1-\zeta^2}} e^{-\zeta\omega_n t} \sin\omega_d t$$

$$c(t) = 1 - e^{-\zeta\omega_n t} \left[\cos\omega_d t + \frac{\zeta}{\sqrt{1-\zeta^2}} \sin\omega_d t \right]$$

- When $\zeta = 0$

$$\begin{aligned}\omega_d &= \omega_n \sqrt{1-\zeta^2} \\ &= \omega_n\end{aligned}$$

$$c(t) = 1 - \cos\omega_n t$$

Time Domain Specifications

Rise Time

$$t_r = \frac{\pi - \theta}{\omega_d} = \frac{\pi - \theta}{\omega_n \sqrt{1 - \zeta^2}}$$

Peak Time

$$t_p = \frac{\pi}{\omega_d} = \frac{\pi}{\omega_n \sqrt{1 - \zeta^2}}$$

Settling Time (2%)

$$t_s = 4T = \frac{4}{\zeta \omega_n}$$

$$t_s = 3T = \frac{3}{\zeta \omega_n}$$

Settling Time (4%)

Maximum Overshoot

$$M_p = e^{-\frac{\pi \zeta}{\sqrt{1 - \zeta^2}}} \times 100$$

System

Pole-zero Plot

Response

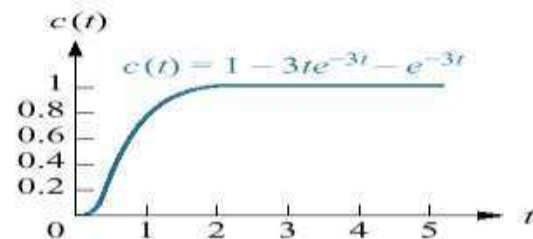
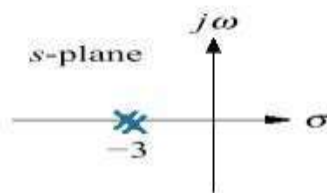
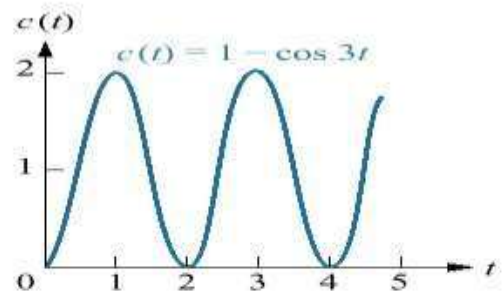
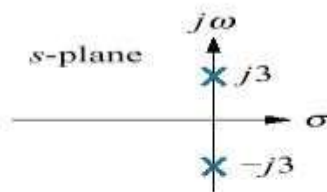
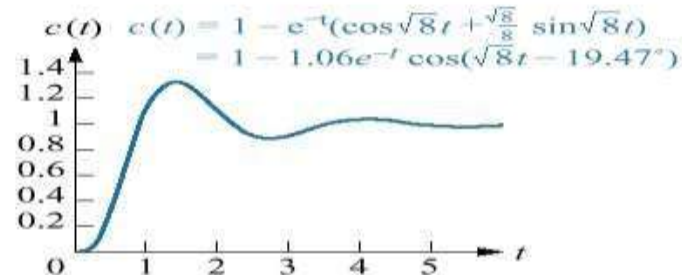
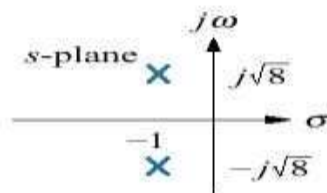
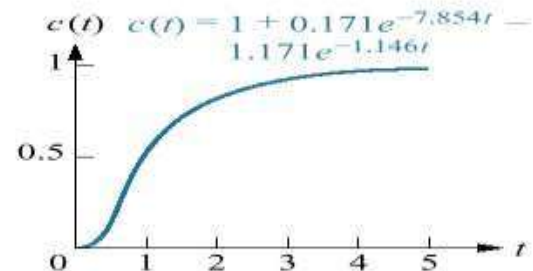
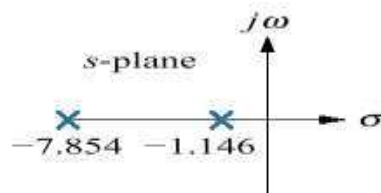
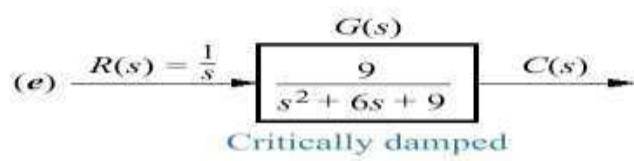
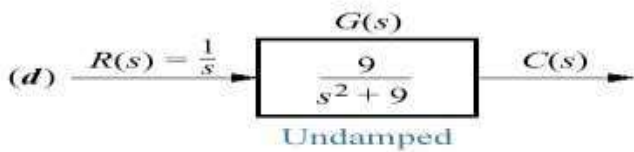
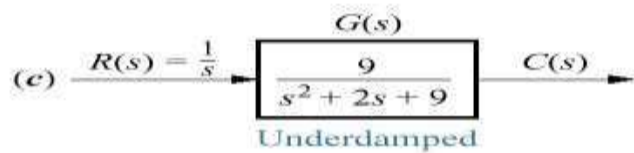
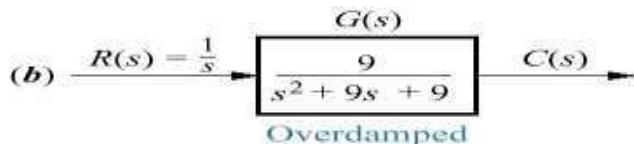
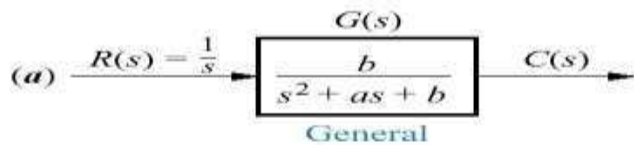

Introduction to Controllers

- The concept of a control system is to sense deviation of the output from the desired value and correct it, till the desired output is achieved.
- The deviation of the actual output from its desired value is called an error. The measurement of error is possible because of feedback.
- The feedback allows us to compare the actual output with its desired value to generate the error.
- The controller is an element which accepts the error in some form and decides the proper corrective action.
- The output of the controller is then applied to the process or final control element. This brings the output back to its desired set point value.
- The controller is the heart of a control system. The accuracy of the entire system depends on how sensitive is the controller to the error detected and how it is manipulating such an error.

Classifications of Industrial Controllers

Most industrial controllers may be classified according to their control actions as:

1. Two-position or on-off controllers
2. **Proportional controllers**
3. **Integral controllers**
4. **Proportional-plus-integral controllers**
5. Proportional-plus-derivative controllers
6. **Proportional-plus-integral-plus-derivative controllers**

Proportional controllers

- In this control mode, the output of the controller is simple proportional to the error $e(t)$.
- The relation between the error $e(t)$ and the controller output p is determined by constant called proportional gain constant denoted as K_p .
- The output of the controller is a linear function of the error $e(t)$.
- Thus each value of the error has a unique value of the controller output.
- The range of the error which covers 0 % to 100 % controller output is called proportional band.
- The basic relationship between output of the controller and error signal is given by,

$$p(t) = K_p e(t)$$

Taking Laplace transform,

$$P(s) = K_p E(s)$$

K_p = Proportional gain constant

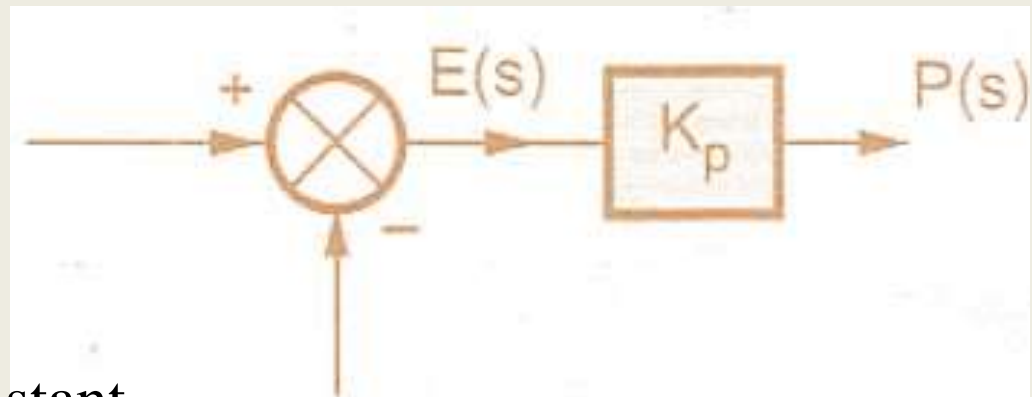

Integral controllers

- In the proportional control mode, error reduces but can not go to zero.
- It finally produces an offset error. It can not adapt with the changing load conditions. To avoid this, another control mode is often used in the control systems which is based on the history of the errors. This mode is called integral mode or reset action controller.
- In such a controller, the value of the controller output $p(t)$ is changed at a rate which is proportioned to the actuating error signal $e(t)$. Mathematically it is expressed as,

$$\frac{dp(t)}{dt} = K_i e(t)$$

K_i = Constant relating error and rate

Taking Laplace transform,

$$sP(s) = K_i E(s) \quad \text{or} \quad P(s) = (K_i/s) E(s)$$

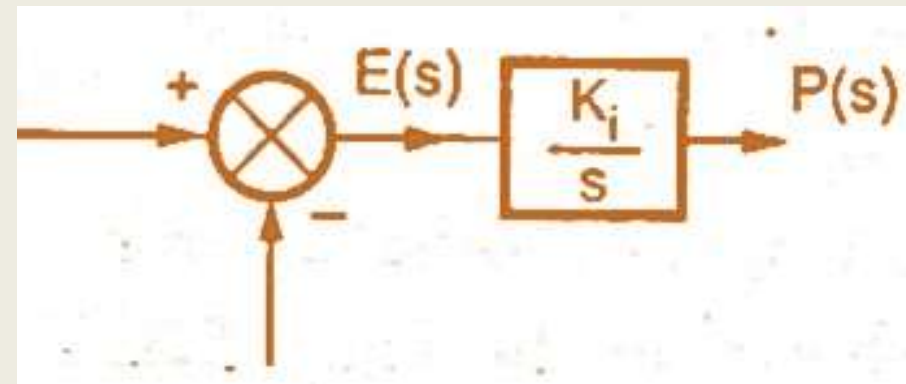

Derivative controllers

- The controller produces a control action that is proportional to the rate at which the error is changing $de(t)/dt$.
- The mathematical equation for the mode is,

$$p(t) = K_d \frac{de(t)}{dt}$$

where K_d = Derivative gain constant.

Taking Laplace transform

$$P(s) = K_d s E(s)$$

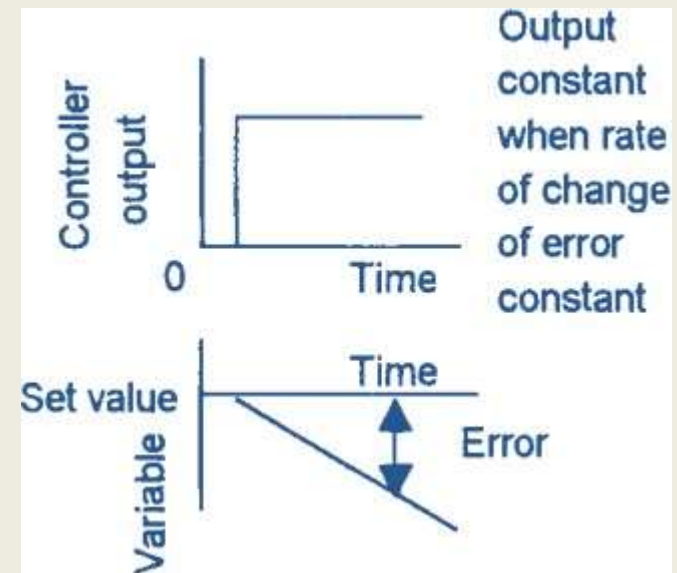
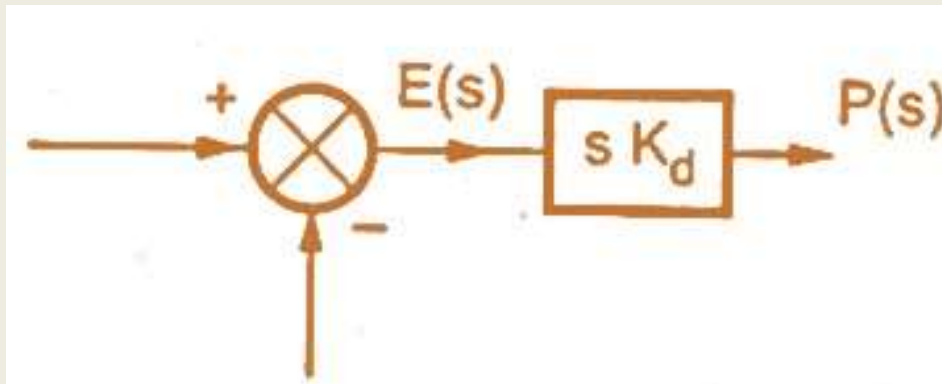

Proportional + Integral controllers

- This is a composite control mode obtained by combining the proportional mode and the integral mode.
- The mathematical expression for such a composite control is,

$$p(t) = K_p e(t) + K_p K_i \int_0^t e(t) dt + p(0)$$

Taking Laplace transform,

$$P(s) = \left[K_p + \frac{K_p K_i}{s} \right] E(s)$$

$$P(s) = K_p \left[1 + \frac{K_i}{s} \right] E(s)$$

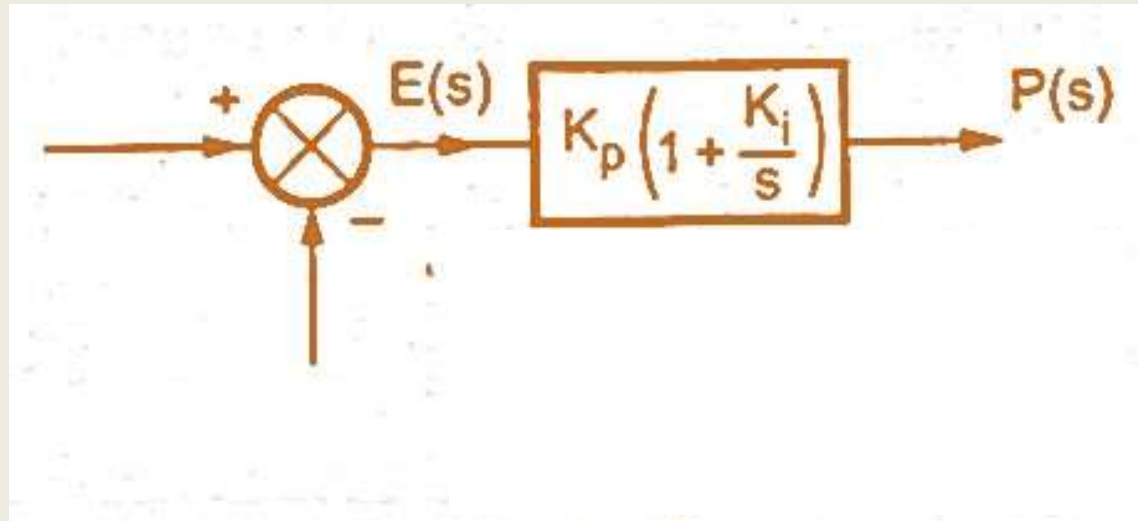

Proportional + Derivative controllers

- The series combination of proportional and derivative control modes gives proportional plus derivative control mode.
- The mathematical expression for the PD composite control is,

$$p(t) = K_p e(t) + K_p K_d \frac{de(t)}{dt} + p(0)$$

- Taking Laplace transform,

$$P(s) = [K_p + K_p K_d s] E(s)$$

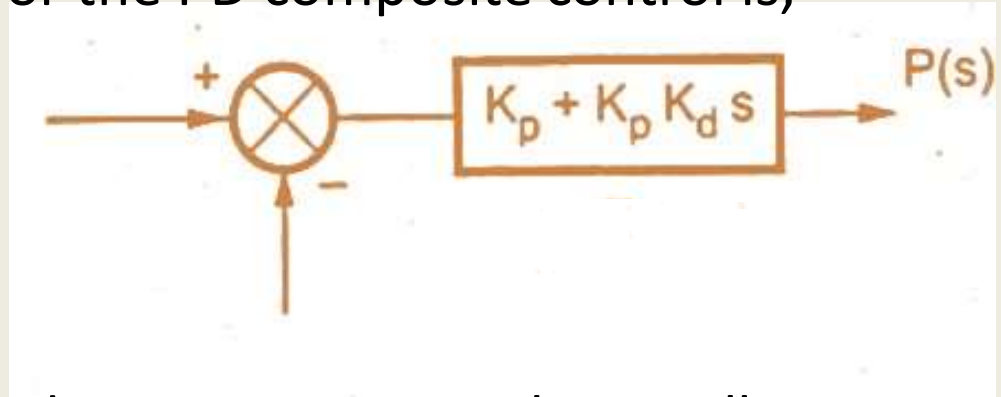

- The addition of a derivative mode to a proportional controller modifies its response to inputs.
- A PD controller provides an element to the response which is largest when the rate of change of the error is greatest and diminishes as it becomes smaller.
- The derivative mode is never used alone because it is not capable of maintaining a control signal under steady error conditions.
- It is always used with the proportional mode and often additionally

Proportional + Integral + Derivative controllers

- The composite controller including the combination of the proportional, integral and derivative control mode is called PID control mode and the controller is called three mode controller.
- It is very much complex to design but very powerful in action.
- Mathematically such a control mode can be expressed as,

$$p(t) = K_p e(t) + K_p K_i \int_0^t e(t) dt + K_p K_d \frac{de(t)}{dt} + p(0)$$

$$P(s) = \left[K_p + \frac{K_p K_i}{s} + K_p K_d s \right] E(s)$$

$$P(s) = \frac{K_p}{s} [s^2 K_d + s + K_i] E(s)$$

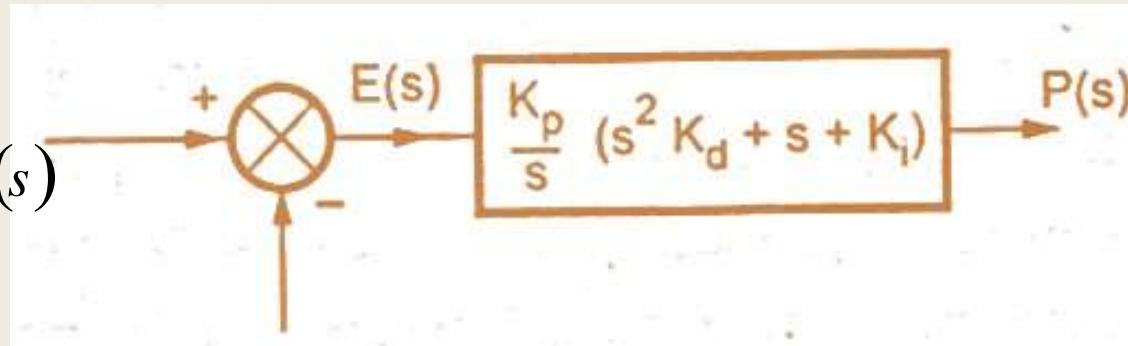

Proportional + Integral + Derivative controllers

- This mode has advantages of all the modes.
- The integral mode eliminates the offset error of the proportional mode and the response is also very fast due to derivative mode.
- The sudden response is produced due to derivative mode.
- Thus it can be used for any process condition.
- With the PID control action, there is no offset, no oscillations with least settling time.
- So there is improvement in both transient as well as steady state response.

P+I+D controllers summary

Proportional action (P)	Arrests	It arrest the change of the Measured Value but always with an Offset from the Measured Value
Integral action (I)	Restores	It removes the Offset
Derivative action (D)	Accelerates	It speeds up the removal of the Offset

UNIT III STABILITY ANALYSIS IN TIME DOMAIN

ROUTH-HURWITZ CRITERIA:-

- Introduces additional combinations of coefficients
- Based on Sturm's theorem.

Central is the idea of the "Routh Table"



Step 1: Write the polynomial as

$$d(s) = a_n s^n + a_{n-1} s^{n-1} + \dots + a_1 s + a_0$$

Step 2

Write the coefficients in 2 rows

- First row starts with a_n
- Second row starts with a_{n-1}
- Other coefficients alternate between rows
- Both rows should be same length
 -) Continue until no coefficients are left
 -) Add zero as last coefficient if necessary

TABLE 6.1 Initial layout for Routh table

s^4	a_4	a_2	a_0
s^3	a_3	a_1	0
s^2			
s^1			
s^0			

Step 3

Complete the third row.

- Call the new entries b_1, \dots, b_k
 -) The third row will be the same length as the first two

$$b_1 = - \frac{\det \begin{pmatrix} a_4 & a_2 \\ a_3 & a_1 \end{pmatrix}}{a_3} \quad b_2 = - \frac{\det \begin{pmatrix} a_4 & a_0 \\ a_3 & 0 \end{pmatrix}}{a_3} \quad b_3 = - \frac{\det \begin{pmatrix} a_4 & 0 \\ a_3 & 0 \end{pmatrix}}{a_3}$$

- The denominator is the first entry from the previous row.
- The numerator is the determinant of the entries from the previous two rows:
 -) The first column
 -) The next column following the coefficient

$$b_k = - \frac{\det \begin{pmatrix} a_n & a_{n-2k} \\ a_{n-1} & a_{n-2k-1} \end{pmatrix}}{a_{n-1}}$$

-) If a coefficient doesn't exist, substitute 0.

TABLE 6.2 Completed Routh table

s^4	a_4	a_2	a_0
s^3	a_3	a_1	0
s^2	$-\frac{\begin{vmatrix} a_4 & a_2 \\ a_3 & a_1 \end{vmatrix}}{a_3} = b_1$	$-\frac{\begin{vmatrix} a_4 & a_0 \\ a_3 & 0 \end{vmatrix}}{a_3} = b_2$	$-\frac{\begin{vmatrix} a_4 & 0 \\ a_3 & 0 \end{vmatrix}}{a_3} = 0$
s^1	$-\frac{\begin{vmatrix} a_3 & a_1 \\ b_1 & b_2 \end{vmatrix}}{b_1} = c_1$	$-\frac{\begin{vmatrix} a_3 & 0 \\ b_1 & 0 \end{vmatrix}}{b_1} = 0$	$-\frac{\begin{vmatrix} a_3 & 0 \\ b_1 & 0 \end{vmatrix}}{b_1} = 0$
s^0	$-\frac{\begin{vmatrix} b_1 & b_2 \\ c_1 & 0 \end{vmatrix}}{c_1} = d_1$	$-\frac{\begin{vmatrix} b_1 & 0 \\ c_1 & 0 \end{vmatrix}}{c_1} = 0$	$-\frac{\begin{vmatrix} b_1 & 0 \\ c_1 & 0 \end{vmatrix}}{c_1} = 0$

Treat each following row in the same way as the third row

- There should be $n + 1$ rows total, including the first row.

Now examine the first column

TABLE 6.3 Completed Routh table for Example 6.1

s^3	1	31	0
s^2	10 1	1030 103	0
s^1	$-\frac{\begin{vmatrix} 1 & 31 \\ 1 & 103 \end{vmatrix}}{1} = -72$	$-\frac{\begin{vmatrix} 1 & 0 \\ 0 & 0 \end{vmatrix}}{1} = 0$	$-\frac{\begin{vmatrix} 1 & 0 \\ 1 & 0 \end{vmatrix}}{1} = 0$
s^0	$-\frac{\begin{vmatrix} 1 & 103 \\ -72 & 0 \end{vmatrix}}{-72} = 103$	$-\frac{\begin{vmatrix} 1 & 0 \\ -72 & 0 \end{vmatrix}}{-72} = 0$	$-\frac{\begin{vmatrix} 1 & 0 \\ -72 & 0 \end{vmatrix}}{-72} = 0$

Theorem 1.

The number of sign changes in the first column of the Routh table equals the number of roots of the polynomial in the Closed Right Half-Plane (CRHP).

Note: Any row can be multiplied by any positive constant without changing the result.

Stability of CT Systems in the s-Plane

- Recall our stability condition for the Laplace transform of the impulse response of a CT linear time-invariant system:

$$H(s) = \frac{b_M s^M + b_{M-1} s^{M-1} + \dots + b_0}{s^N + a_{N-1} s^{N-1} + \dots + s_0} \Leftrightarrow \operatorname{Re}(p_i) < 0 \quad \text{for } i = 1, 2, \dots, N$$

- This implies the poles are in the left-half plane.

This also implies:

$$|h(t)| \rightarrow 0 \text{ as } t \rightarrow \infty \quad \text{and} \quad \int_{-\infty}^{\infty} |h(t)| dt < \infty$$

- A system is said to be marginally stable if its impulse response is bounded:

$$|h(t)| \leq c \quad \forall t$$

In this case, at least one pole of the system lies on the $j\omega$ -axis.

- Recall periodic signals also have poles on the $j\omega$ -axis because they are marginally stable.
- Also recall that the left-half plane maps to the **inside** of the unit circle in the z-plane for discrete-time (sampled) signals.
- We can show that circuits built from passive components (RLC) are always stable if there is some resistance in the circuit.

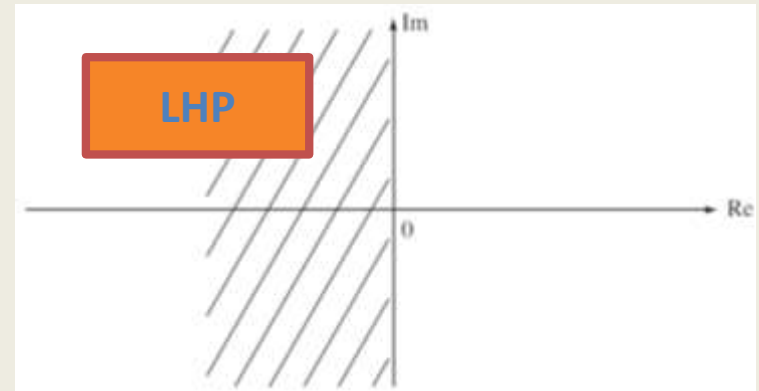

Stability of CT Systems in the s-Plane

• Example: Series RLC Circuit

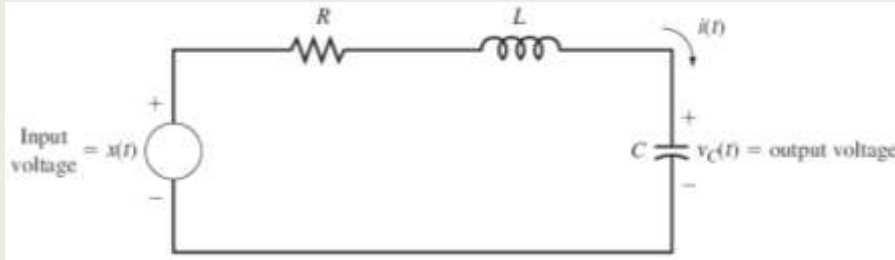

$$H(s) = \frac{1/LC}{s^2 + (R/L)s + 1/LC}$$

Using the quadratic formula:

$$p_1, p_2 = -\frac{R}{2L} \pm \sqrt{\left(\frac{R}{2L}\right)^2 - \frac{1}{LC}}$$

Case 1:

$$\left(\frac{R}{2L}\right)^2 - \frac{1}{LC} \geq 0 \Rightarrow \text{two real poles}$$

$$-\frac{R}{2L} - \sqrt{\left(\frac{R}{2L}\right)^2 - \frac{1}{LC}} < 0 \Rightarrow \text{pole in LHP}$$

\Rightarrow always stable

$$-\frac{R}{2L} + \sqrt{\left(\frac{R}{2L}\right)^2 - \frac{1}{LC}} < 0$$

quadratic term must be $< \frac{R}{2L}$

\Rightarrow always stable

Case 2:

$$\left(\frac{R}{2L}\right)^2 - \frac{1}{LC} < 0 \Rightarrow \text{two complex poles,}$$

$$\text{Re}\{p_1\} = -\frac{R}{2L} \Rightarrow \text{always stable}$$

The RLC circuit
is always stable. Why?

The Routh-Hurwitz Stability Test

- The procedures for determining stability do not require finding the roots of the denominator polynomial, which can be a daunting task for a high-order system (e.g., 32 poles).
- The Routh-Hurwitz stability test is a method of determining stability using simple algebraic operations on the polynomial coefficients. It is best demonstrated through an example.

• Consider:

$$A(s) = a_N s^N + a_{N-1} s^{N-1} + \dots + a_1 s + a_0$$

• Construct the Routh array:

s^N	a_N	a_{N-2}	a_{N-4}	...
s^{N-1}	a_{N-1}	a_{N-3}	a_{N-5}	...
s^{N-2}	b_{N-2}	b_{N-4}	b_{N-6}	...
s^{N-3}	c_{N-3}	c_{N-5}	c_{N-7}	...
\vdots	\vdots	\vdots	\vdots	\vdots
s^2	d_2	d_0	0	...
s^1	e_1	0	0	...
s^0	f_0	0	0	...

N even : $(N / 2) + 1$ columns

N odd : $(N + 1) / 2$ columns

$$b_{N-2} = \frac{a_{N-1} a_{N-2} - a_N a_{N-3}}{a_{N-1}} = a_{N-2} - \frac{a_N a_{N-3}}{a_{N-1}}$$

$$b_{N-4} = \frac{a_{N-1} a_{N-4} - a_N a_{N-5}}{a_{N-1}} = a_{N-4} - \frac{a_N a_{N-5}}{a_{N-1}}$$

Number of sign changes in 1st column = number of poles in the RHPRLC circuit is always stable

Routh-Hurwitz Examples

- **Example:** $A(s) = s^2 + a_1s + a_0$

$$\begin{array}{rcc} s^2 & 1 & a_0 \\ s^1 & a_1 & 0 \\ s^0 & \frac{a_1 a_0 - (1)(0)}{a_1} = a_0 & 0 \end{array}$$

if $a_1 > 0$ and $a_0 < 0 \Rightarrow$ one sign change \Rightarrow 1 RHP pole \Rightarrow unstable

if $a_1 < 0$ and $a_0 < 0 \Rightarrow$ one sign change \Rightarrow 1 RHP pole \Rightarrow unstable

if $a_1 < 0$ and $a_0 > 0 \Rightarrow$ two sign changes \Rightarrow 2 RHP poles \Rightarrow unstable

- **Example:** $A(s) = s^3 + a_2s^2 + a_1s + a_0$

$$\begin{array}{rcc} s^3 & 1 & a_1 \\ s^2 & a_2 & a_0 \\ s^1 & \frac{a_2 a_1 - (1)a_0}{a_2} = a_1 - \frac{a_0}{a_2} & 0 \\ s^0 & a_0 & 0 \end{array}$$

if $a_2 < 0$ and $a_0 > 0 \Rightarrow$ two sign changes \Rightarrow 2 RHP poles \Rightarrow unstable

Analysis of the Step Response For A 1st-Order System

- Recall the transfer function for a 1st-order differential equation:

$$H(s) = \frac{k}{s - p}$$

$$X(s) = \mathcal{L}\{u(t)\} = \frac{1}{s}$$

$$Y(s) = H(s)X(s) = \frac{k}{s(s - p)}$$

$$Y(s) = \frac{-k/p}{s} + \frac{k/p}{s - p}$$

$$y(t) = -\frac{k}{p}(1 - e^{pt})u(t)$$

```
num = 1; den = [1 -p];  
t = 0:0.05:10;  
y = step(num, den, t);
```

- Define a time constant as the time it takes for the response to reach $1/e$ (37%) of its value.
- The time constant in this case is equal to $-1/p$. Hence, the real part of the pole, which is the distance of the pole from the $j\omega$ -axis, and is the bandwidth of the pole, is directly related to the time constant.

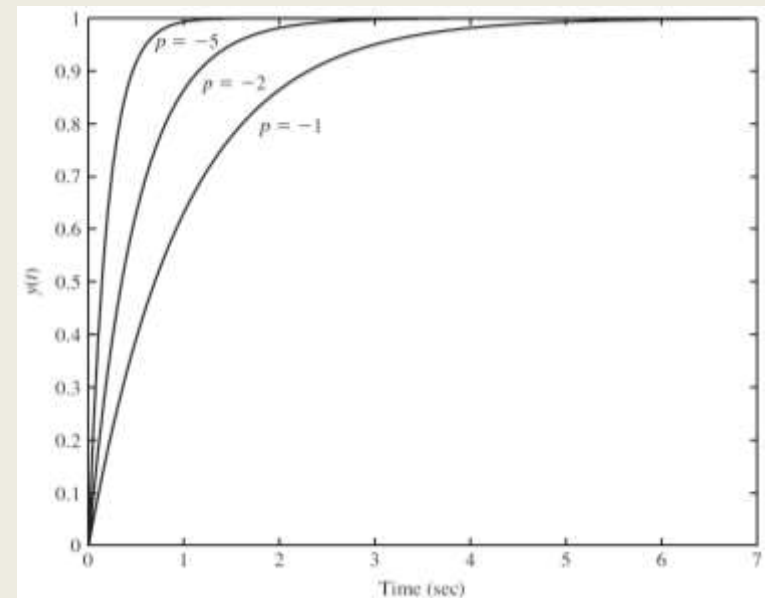
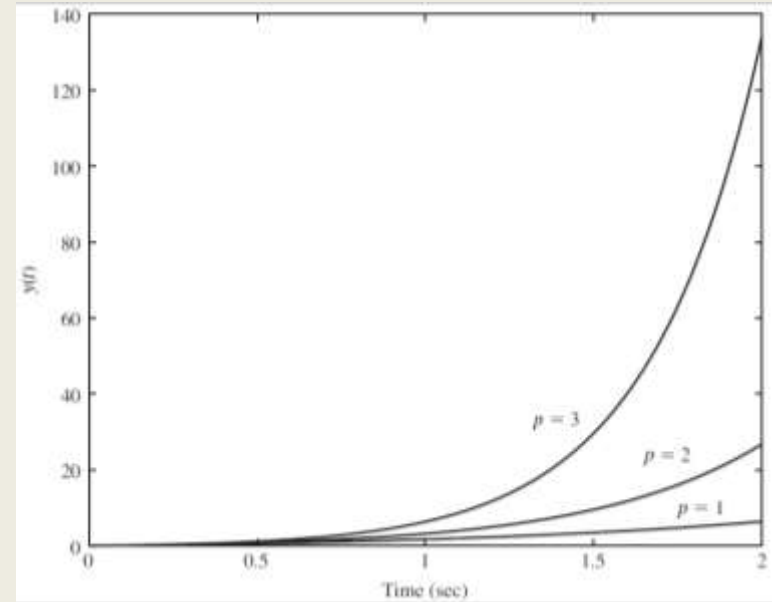

Consider the transfer function

$$\hat{G}(s) = \frac{1}{s^5 + 2s^4 + 2s^3 + 4s^2 + 11s + 10}$$

The Routh Table begins:

s^5	1	2	11
s^4	2	4	10
s^3	0	6	0

The next entry in the table will be

$$-\frac{\det \begin{pmatrix} 2 & 4 \\ 0 & 6 \end{pmatrix}}{0} = \frac{-12}{0}$$

Which is **problematic**.

Note: If there is a zero in the first column, the system is only marginally stable

- Small changes in the coefficients lead to instability.

The solution is to use ϵ instead of 0 in the first column.

$$\begin{array}{c|ccc} s^5 & 1 & 2 & 11 \\ s^4 & 2 & 4 & 10 \\ s^3 & \epsilon & 6 & 0 \end{array}$$

Now the next entry in the table will be

$$-\frac{\det \begin{pmatrix} 2 & 4 \\ \epsilon & 6 \end{pmatrix}}{\epsilon} = \frac{-(12 - 4\epsilon)}{\epsilon}$$

Because ϵ is infinitely small, we let $12 - 4\epsilon = 12$.

Assume $\epsilon > 0$

- We have at least one sign change
- At least one unstable pole.

We can keep calculating if necessary.

$$\begin{array}{r|rrr}
 s^5 & 1 & 2 & 11 \\
 s^4 & 2 & 4 & 10 \\
 s^3 & 0 & 6 & 0 \\
 s^3 & \epsilon & 6 & 0 \\
 s^2 & \frac{4\epsilon - 12}{\epsilon} & \frac{10\epsilon}{\epsilon} & 0 \\
 s^2 & \underline{-12} & 10 & 0 \\
 s & \frac{\epsilon}{10\epsilon^2 + 72} & 0 & 0 \\
 s & 6 & 0 & 0 \\
 s & 10 & 0 & 0 \\
 1 & 10 & 0 & 0
 \end{array}$$

So there are two sign changes

- Two unstable poles

Root Locus:

the locus of roots of the characteristic equation of the **closed-loop** system as a specific parameter (usually, gain K) is varied from 0 to ∞ .

The advantages of RL approach:

1. Avoiding tedious and complex roots-solving calculation
2. Clearly showing the contributions of each loop poles or zeros to the location of the closed-loop poles.
3. Indicating the manner in which the loop poles and zeros should be modified so that the response meets system performance specifications.

Properties of Root Loci

- 1 $K = 0$ and $K = \pm\infty$ points of Root Loci
- 2 Number of Branches on the RL
- 3 Symmetry of the RL
- 4 Root Loci on the real-axis
- 5 Asymptotes of the RL
- 6 Breakaway points on the RL
- 7 Departure angle and arrival angle of RL
- 8 Intersection of the RL with the imaginary axis
- 9 The sum of the roots and the product of the roots of the closed-loop characteristic equation

1 $K = 0$ and $K = \infty$ points

Root loci originate on the **poles** of $G(s)H(s)$ (for $K=0$) and terminates on the **zeros** of $G(s)H(s)$ (as $K=\infty$).

RL
Equation:

$$G(s)H(s) = \frac{K \prod_{i=1}^m (s - Z_i)}{\prod_{i=1}^n (s - P_i)} = -1$$

Magnitude
Equation:

$$\frac{K \prod_{i=1}^m |s - Z_i|}{\prod_{i=1}^n |s - P_i|} = 1$$

$$K = \frac{\prod_{i=1}^n |s - P_i|}{\prod_{i=1}^m |s - Z_i|}$$

$K = 0 \quad \rightarrow s = P_i \quad \rightarrow$ Root loci start from **poles** of $G(s)H(s)$

$K = \infty \quad \rightarrow s = Z_i \quad \rightarrow$ Root loci end at **zeros** of $G(s)H(s)$.

2 Number of branches on the RL

n th-order system, RL have n starting points and RL have n branches

RL
Equation:

$$G(s)H(s) = \frac{K \prod_{i=1}^m (s - Z_i)}{\prod_{i=1}^n (s - P_i)} = -1$$

The order of the characteristic equation is $n \rightarrow$ as K varies from 0 to ∞ , n roots change $\rightarrow n$ root loci.

For a real physical system, the number of poles of $G(s)H(s)$ are more than zeros, i.e. $n > m$.

n root loci end at open-loop zeros (finite zeros);

m root loci end at open-loop zeros (finite zeros);

$(n - m)$ root loci end at $(n - m)$ infinite zeros.

3 Symmetry of the RL

The RL are symmetrical with respect to the real axis of the s -plane.

The roots of characteristic equation are **real** or **complex-conjugate**.

Therefore, we only need to draw the RL **on the up half s -plane** and **on the real-axis**, the rest can be obtained by plotting its mirror image.

4 RL on the Real Axis

real axis

right

odd

zero: z_1 poles: p_1, p_2, p_3, p_4, p_5

Pick a test point s_1 on $[p_2, p_3]$

$$\angle G(s_1)H(s_1) = \sum_{i=1}^1 \angle(s_1 - z_i) - \sum_{i=1}^5 \angle(s_1 - p_i)$$

? $\Leftrightarrow \angle G(s_1)H(s_1) = (2l + 1)180^\circ$

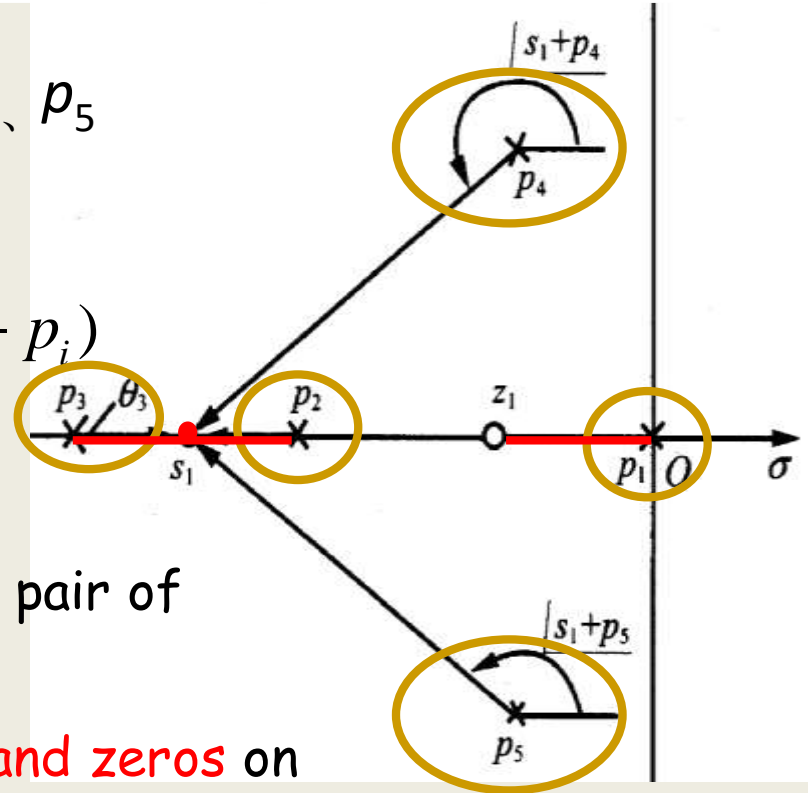

The sum of angles provided by every pair of **complex conjugate poles** are 360° ;

The angle provided by **all the poles and zeros** on the **right** of s_1 is 180° ;

The angle provided by **all the poles and zeros** on the **left** of s_1 is 0° .

Example

Consider the following loop transfer function

$$G(s)H(s) = \frac{K(s+1)(s+4)(s+6)}{s^2(s+2)(s+3)^2}$$

Determine its root loci on the real axis.

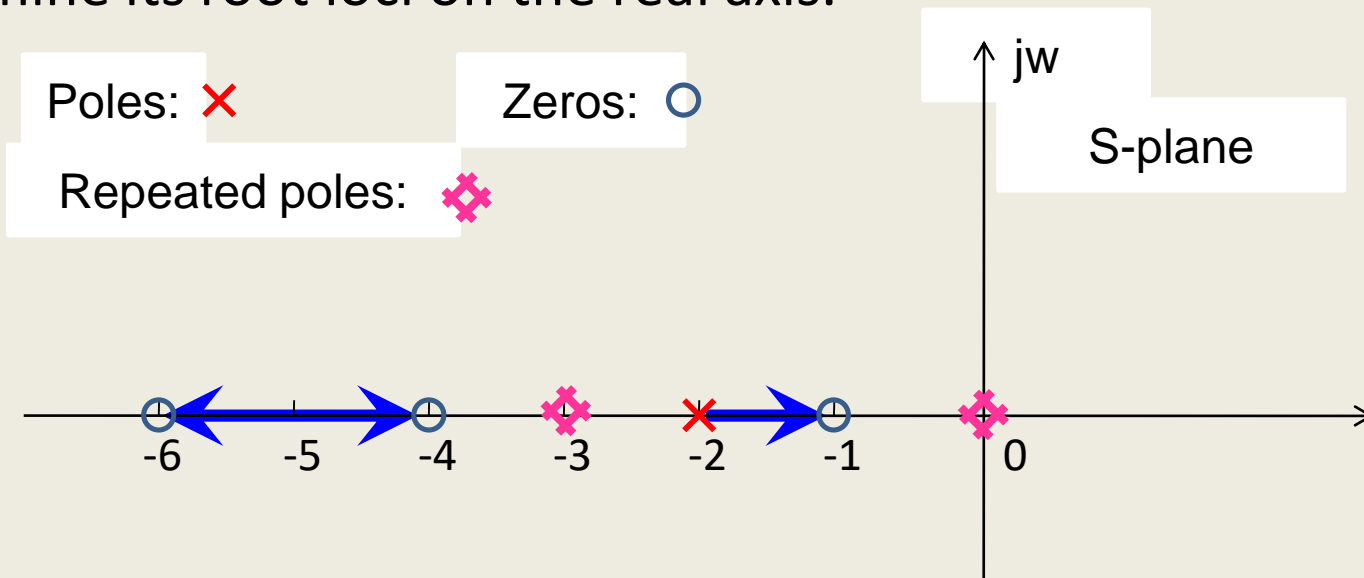

On the **right** of $[-2, -1]$ the number of real zeros and poles=**3**.

On the **right** of $[-6, -4]$, the number of real zeros and poles=**7**.

5 Asymptotes of RL

$$n \neq m$$

$$2|n-m|$$
$$|s| = \infty$$

RL

Equation:

$$G(s)H(s) = \frac{K \prod_{i=1}^m (s - Z_i)}{\prod_{i=1}^n (s - P_i)} = -1$$

The angles between the asymptotes and the real axis are ($i = 0, 1, 2, \dots, n-m-1$) :

$$\varphi_a = \frac{(2i+1)180^\circ}{n-m}$$

The asymptotes intersect the real axis at:

$$\sigma_a = \frac{\sum_{i=1}^n p_i - \sum_{i=1}^m z_i}{n-m}$$

Example

Consider the following loop transfer function

$$G(s)H(s) = \frac{K(0.25s + 1)}{s(s + 1)(0.2s + 1)} = \frac{K^*(s + 4)}{s(s + 1)(s + 5)}$$

Determine the asymptotes of its root loci.

3 poles: 0, -1, -5

$$n - m = 3 - 1 = 2$$

1 zero: -4

The asymptotes intersect the real axis at

$$\sigma_a = \frac{\sum_{i=1}^n p_i - \sum_{i=1}^m z_i}{n - m} = \frac{(0) + (-1) + (-5) - (-4)}{3 - 1} = -1$$

The angles between the asymptotes and the real axis are

$$\varphi_a = \frac{(2i + 1)180^\circ}{n - m}, \quad i = 0, 1 \quad \varphi_a = 90^\circ, 270^\circ$$

Example

Consider the following loop transfer function

$$G(s)H(s) = \frac{K(s+1)}{s(s+4)(s^2+2s+2)}$$

Determine the asymptotes of its root loci.

4 poles: 0, $-1+j$, $-1-j$, -4

1 zero: -1

$$n-m=4-1=3$$

The asymptotes intersect the real axis at

$$\begin{aligned}\sigma_a &= \frac{\sum_{i=1}^n p_i - \sum_{i=1}^m z_i}{n-m} \\ &= \frac{(0) + (-1+j) + (-1-j) + (-4) - (-1)}{4-1} = -\frac{5}{3}\end{aligned}$$

The angles between the asymptotes and the real axis are

$$\varphi_a = \frac{(2i+1)180^\circ}{n-m}, \quad i = 0, 1, 2 \quad \varphi_a = 60^\circ, 180^\circ, 300^\circ$$

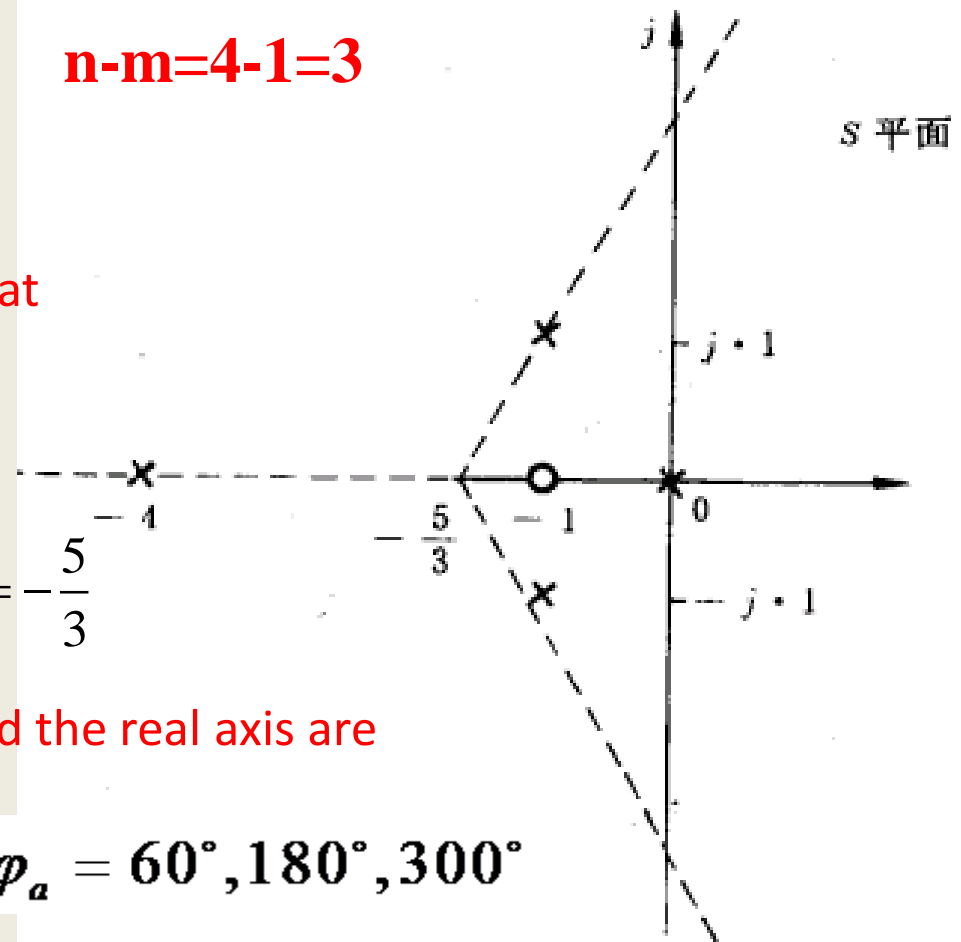

6 Breakaway points on the RL

Breakaway points on the RL correspond to multi-order roots of the RL equation.

The breakaway points on the RL are determined by finding the roots of $dK/ds=0$ or $dG(s)H(s)=0$.

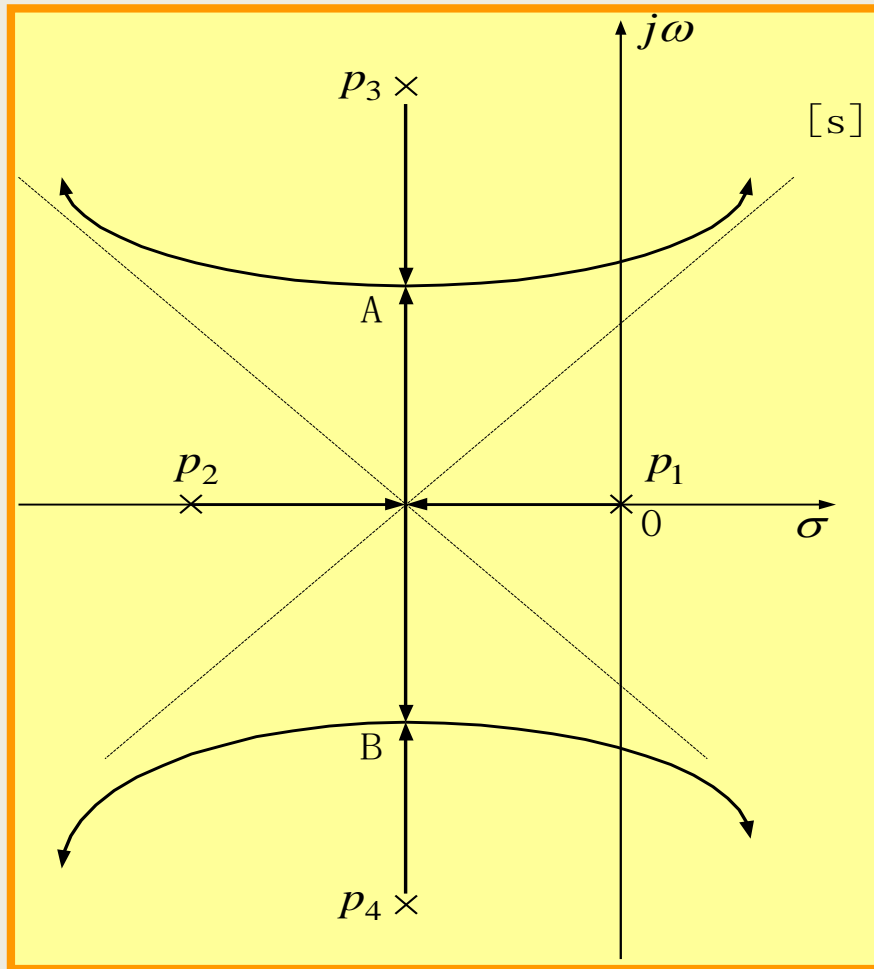

Example

The poles and zeros of $G(s)H(s)$ are shown in the following figure, determin its root loci.

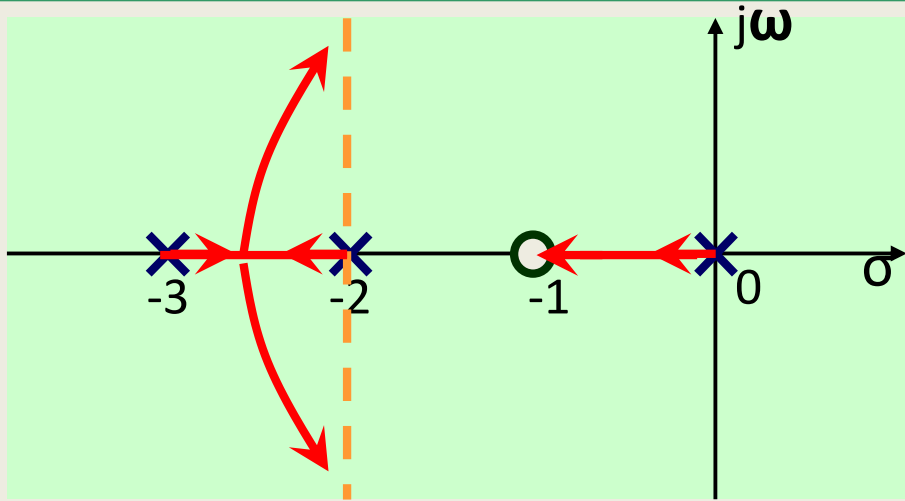

Rule 1、 2、 3→

RL have **three** branches, starting from poles 0、 -2、 -3, ending at on finite zero -1 and two infinite zeros. The RL are symmetrical with respect to the real axis.

Ruel 4→The intersections [-1,0] and[-3,-2] on the real axis are RL.

Rule 5→The RL have two asymptotes($n - m = 2$)

$$\varphi_a = \frac{(2i + 1)180^\circ}{n - m} = 90^\circ, 270^\circ$$

$$\sigma_a = \frac{\sum_{i=1}^n p_i - \sum_{i=1}^m z_i}{n - m} = \frac{0 + (-2) + (-3) - (-1)}{2} = -2$$

$i = 0, 1$

Rule 6→The RL have breakaway points on the real axis (within[-3,-2])

$$\frac{1}{\sigma_b + 1} = \frac{1}{\sigma_b - 0} + \frac{1}{\sigma_b + 2} + \frac{1}{\sigma_b + 3} \quad \sigma_b = -2.47$$

Example

$$G(s)H(s) = \frac{K}{s(s+4)(s^2+4s+20)}$$

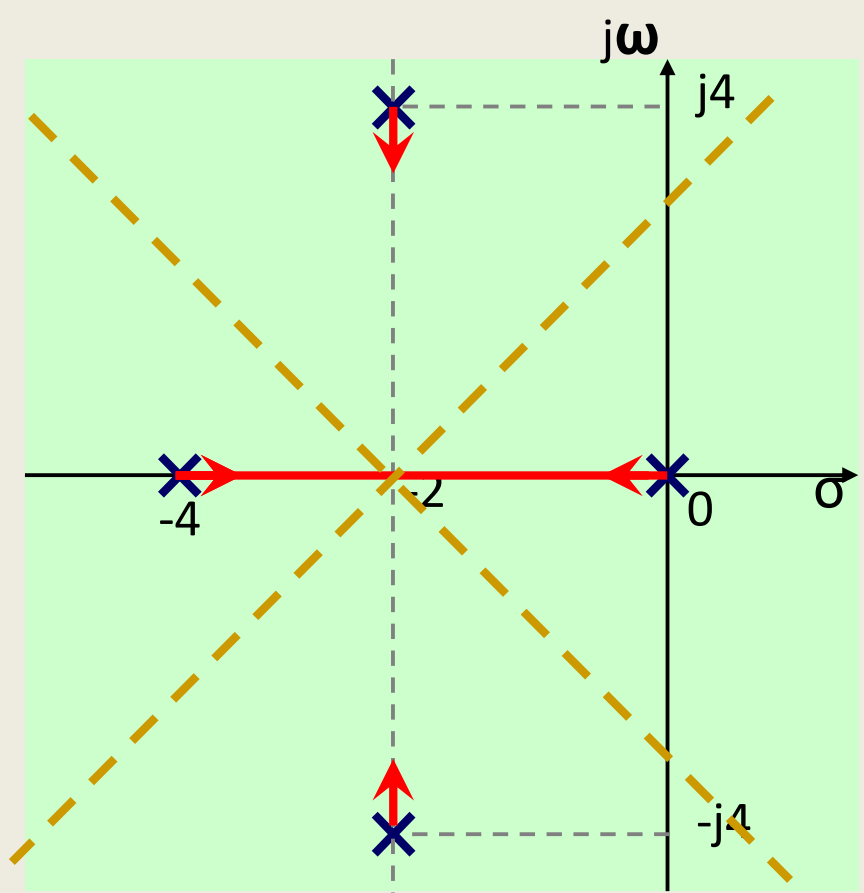

Rule 1, 2, 3, 4 → n=4, m=0
 the RL are symmetrical with respect to the real axis;
 the RL have **four branches** which start from poles 0, -4 and $-2 \pm j4$;
 the RL end at infinite zeros;
 the intersection $[-4, 0]$ on the real-axis is RL

Rule 5 →

The RL have four asymptotes.

$$\varphi_a = \frac{(2l+1)180^\circ}{n-m} \quad (l = 0, 1, 2, 3)$$

$$= 45^\circ, 135^\circ, 225^\circ, 315^\circ$$

$$\sigma_a = \frac{\sum_{i=1}^n p_i - \sum_{i=1}^m z_i}{n-m} = \frac{0 + (-4) + (-2) + (-2)}{4} = -2$$

Example

$$G(s)H(s) = \frac{K}{s(s+4)(s^2+4s+20)}$$

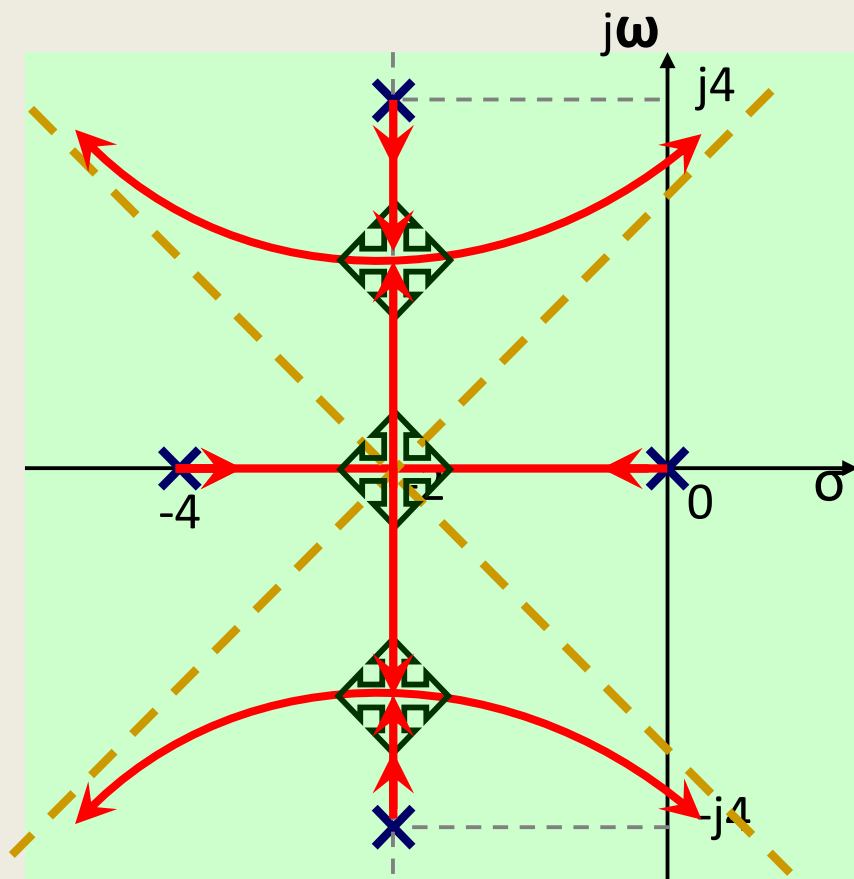

Rule 6 → the breakaway point of the RL

$$1 + G(s)H(s) = 1 + \frac{K}{s(s+4)(s^2+4s+20)} = 0$$

$$K = -s(s+4)(s^2+4s+20) = -(s^4 + 8s^3 + 36s^2 + 80s)$$

$$\frac{dK}{ds} = -(4s^3 + 24s^2 + 72s + 80) = 0$$

$$\sigma_{b1} = -2$$

$$\sigma_{b2,3} = -2 \pm j2.45$$

7 Angles of departure and angles of arrival of the RL

The angle of **departure or arrival** of a root locus at a **pole or zero**, respectively, of $G(s)H(s)$ denotes the angle of the **tangent** to the locus near the point.

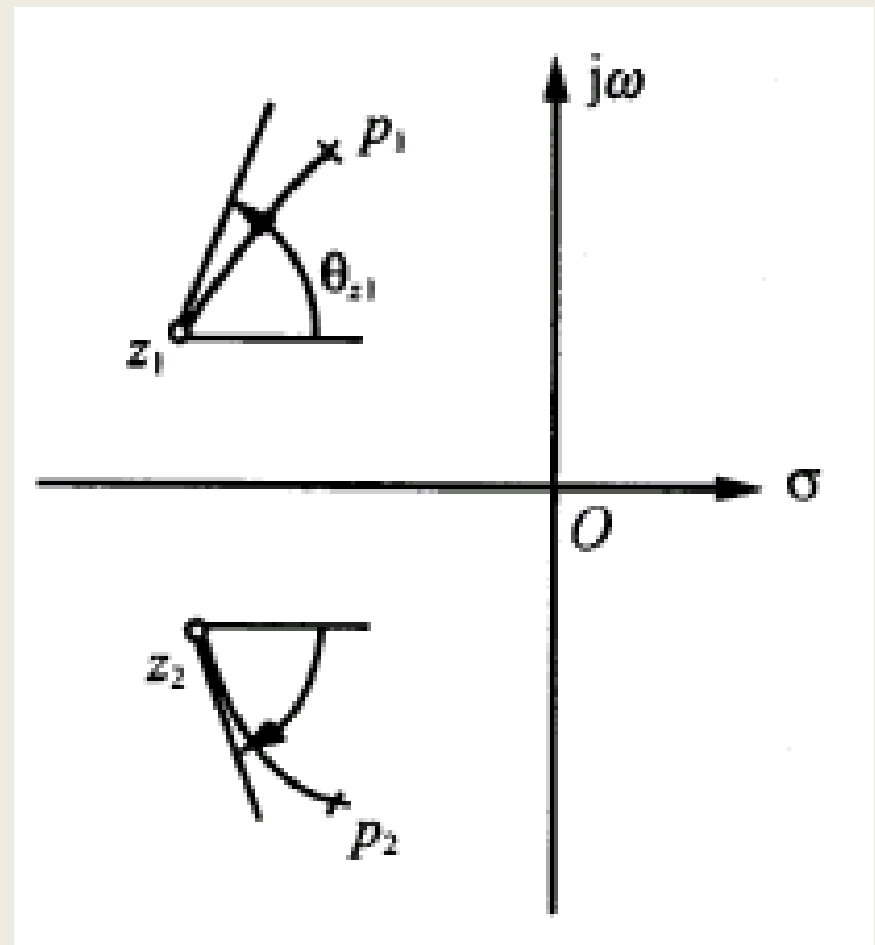
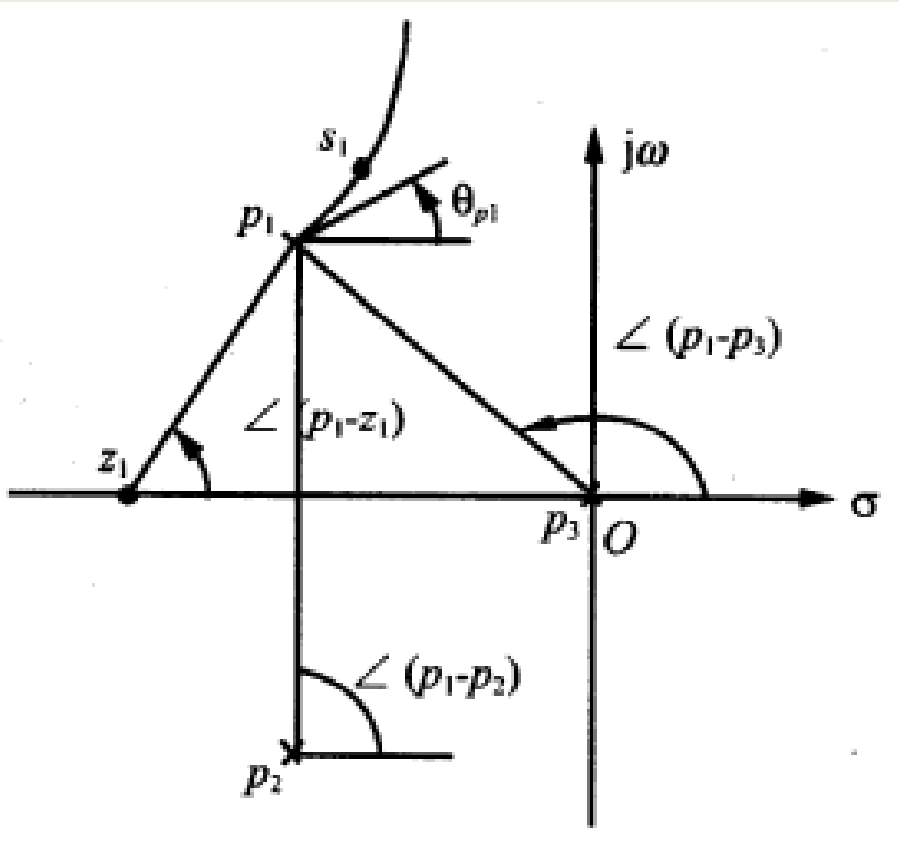

Angle of Departure:

$$\theta_{p_j} = (2l + 1)\pi + \sum_{i=1}^m \angle(p_j - z_i) - \sum_{\substack{i=1 \\ i \neq j}}^n \angle(p_j - p_i), \quad l = 0, \pm 1, \dots$$

Pick up a point s_1 that is close to p_1

Applying **Angle Equation (AE)**

$$\angle(s_1 - z_1) - \angle(s_1 - p_1) - \angle(s_1 - p_2) - \angle(s_1 - p_3) = (2l + 1)\pi$$

$s_1 \rightarrow p_1$ $\angle(s_1 - p_1) \rightarrow$ angle of departure θ_{p_1}

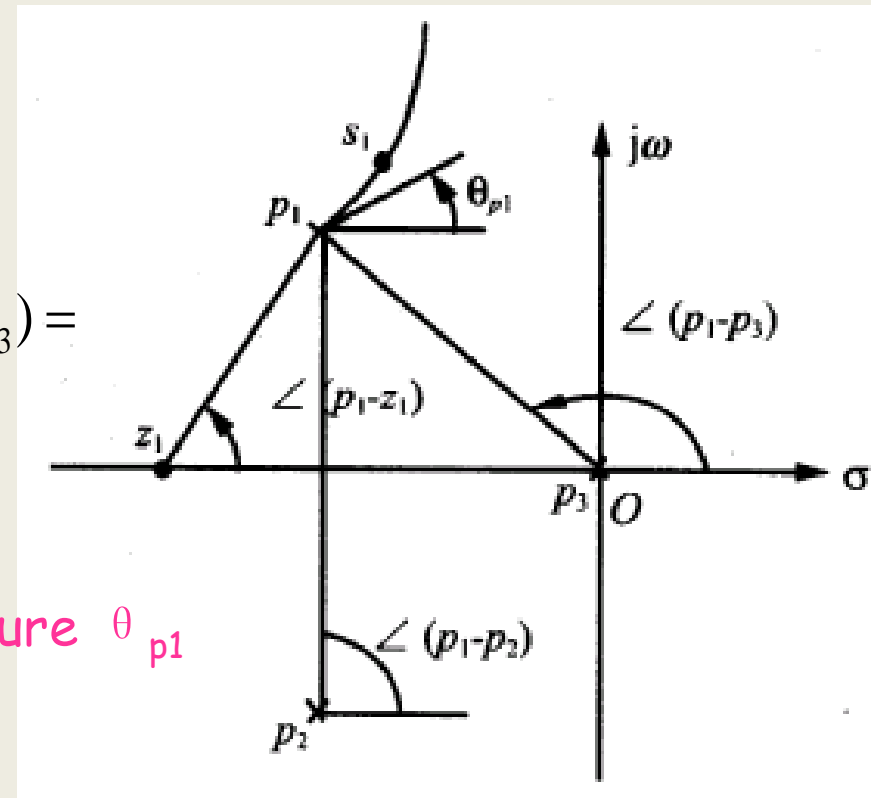

$$\theta_{p_1} = (2l + 1)\pi + \angle(p_1 - z_1) - \angle(p_1 - p_2) - \angle(p_1 - p_3)$$

Angle of Arrival:

$$\varphi_{z_j} = (2l + 1)\pi + \sum_{i=1}^n \angle(z_j - p_i) - \sum_{\substack{i=1 \\ i \neq j}}^m \angle(z_j - z_i), \quad l = 0, \pm 1, \dots$$

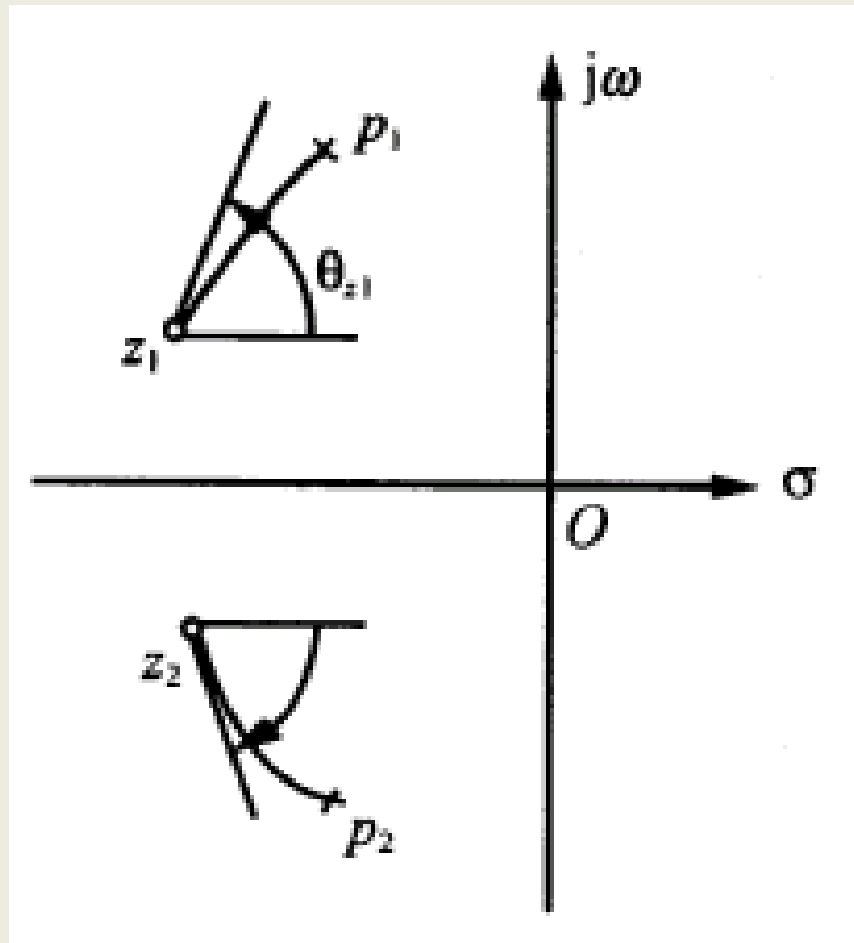

Example

Consider the following loop transfer function

$$G(s)H(s) = \frac{Ks}{(s+1)^2(s-1)}$$

Determine its RL when K varies from 0 to ∞ .

3 poles $P_{1,2}=-1$ (repeated poles) $P_3=1$; 1 zero $Z_1=0$, $n-m=2$.
 3 branches , 2 asymptotes

$$\sigma_a = \frac{\sum_{i=1}^n P_i - \sum_{i=1}^m Z_i}{n-m} = \frac{-1-1+1-0}{3-1} = -0.5$$

$$\phi_a = \frac{(2l+1)\pi}{n-m} = \frac{\pi}{2}, \frac{3\pi}{2}$$

Angle of departure:

$$\theta_{pl} = (2l+1)\pi + \pi - \pi - \frac{\pi}{2} = \frac{\pi}{2}, \frac{3\pi}{2}$$

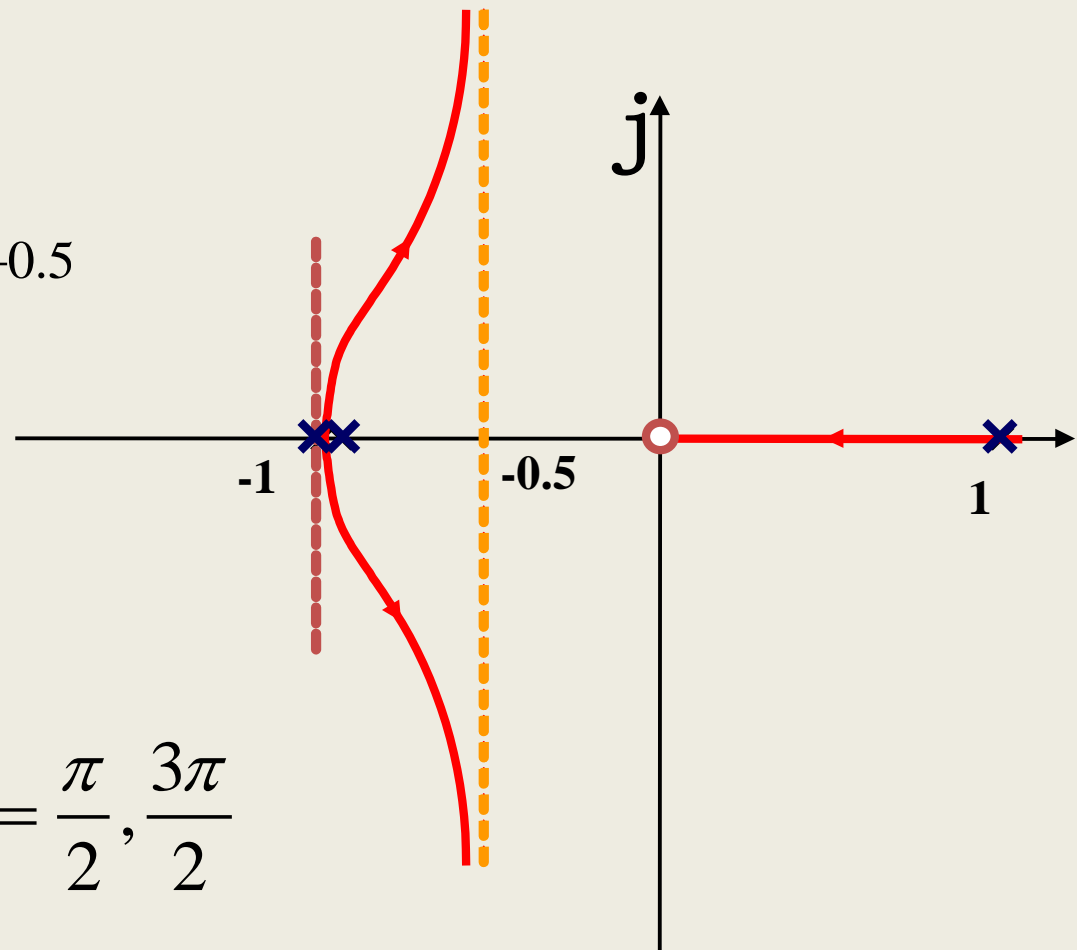

8 Intersection of the RL with the Imaginary Axis

Intersection of the RL with Im-axis → ?

The characteristic equation have roots on the Im-axis and the system is **marginally stable**.

Method 2

$$s = j\omega \rightarrow 1 + G(s)H(s) = 0 \rightarrow 1 + G(j\omega)H(j\omega) = 0$$

$$\begin{cases} \text{Re}[1 + G(j\omega)H(j\omega)] = 0 \\ \text{Im}[1 + G(j\omega)H(j\omega)] = 0 \end{cases} \rightarrow \omega$$

Example

Consider the following loop transfer function

$$G(s)H(s) = \frac{K}{s(s+1)(s+2)}$$

Determine the intersection of the RL with Im-axis.

Method 1

Closed-loop CE: $s(s+1)(s+2) + K = s^3 + 3s^2 + 2s + K = 0$

Routh's Tabulation:

s^3	1	2
s^2	3	K
s^1	$\frac{6-K}{3}$	0
s^0	K	

Marginally stable:
 $K = 6$

Auxiliary equation:

$$3s^2 + 6 = 0$$

Intersection point: $s = \pm j\sqrt{2}$

Example

Consider the following loop transfer function

$$G(s)H(s) = \frac{K}{s(s+1)(s+2)}$$

Determine the intersection of the RL with Im-axis.

Method 2

Closed-loop CE: $s(s+1)(s+2) + K = s^3 + 3s^2 + 2s + K = 0$

$s = j\omega$ → Closed-loop CE → $1 + G(j\omega)H(j\omega) = 0$

$$(j\omega)^3 + 3(j\omega)^2 + 2(j\omega) + K = (K - 3\omega^2) + j(2\omega - \omega^3) = 0$$

Real part: $K - 3\omega^2 = 0$

Imaginary part: $2\omega - \omega^3 = 0$

$$\left. \begin{array}{l} K - 3\omega^2 = 0 \\ 2\omega - \omega^3 = 0 \end{array} \right\} \Rightarrow \omega = \pm\sqrt{2} \quad K = 6$$

UNIT IV FREQUENCY RESPONSE ANALYSIS

What is frequency response of a system?

- The frequency response of a system is defined as the steady-state response of the system to a sinusoidal input signal.
- The sinusoid is a unique input signal, and the resulting output signal for a linear system, as well as signals throughout the system, is sinusoidal in the steady-state.

A blue ribbon banner with a 3D effect, featuring a central cylindrical section and two flared ends. The text "Bode Plot Definition" is written in white on the central section.

Bode Plot Definition

What is Bode Plot?

Bode Plot is a (semi log) plot of the transfer function magnitude and phase angle as a function of frequency.

Frequency Response

- The transfer function can be separated into magnitude and phase angle information

$$\mathbf{H}(j\omega) = |\mathbf{H}(j\omega)| \angle \mathbf{\Phi}(j\omega)$$

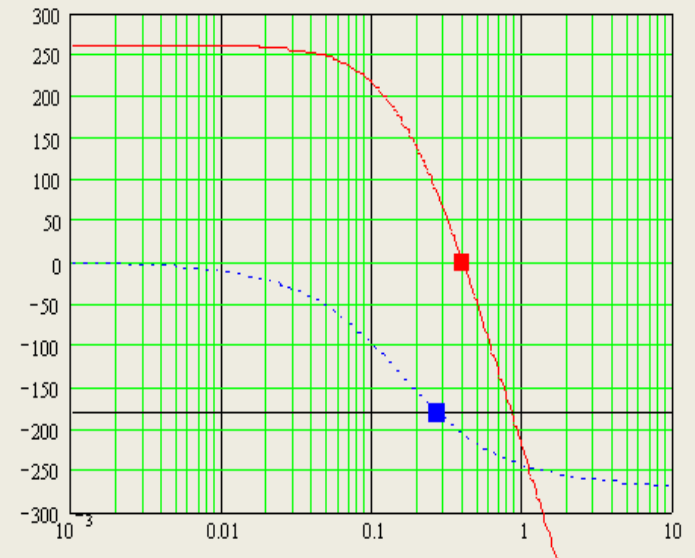
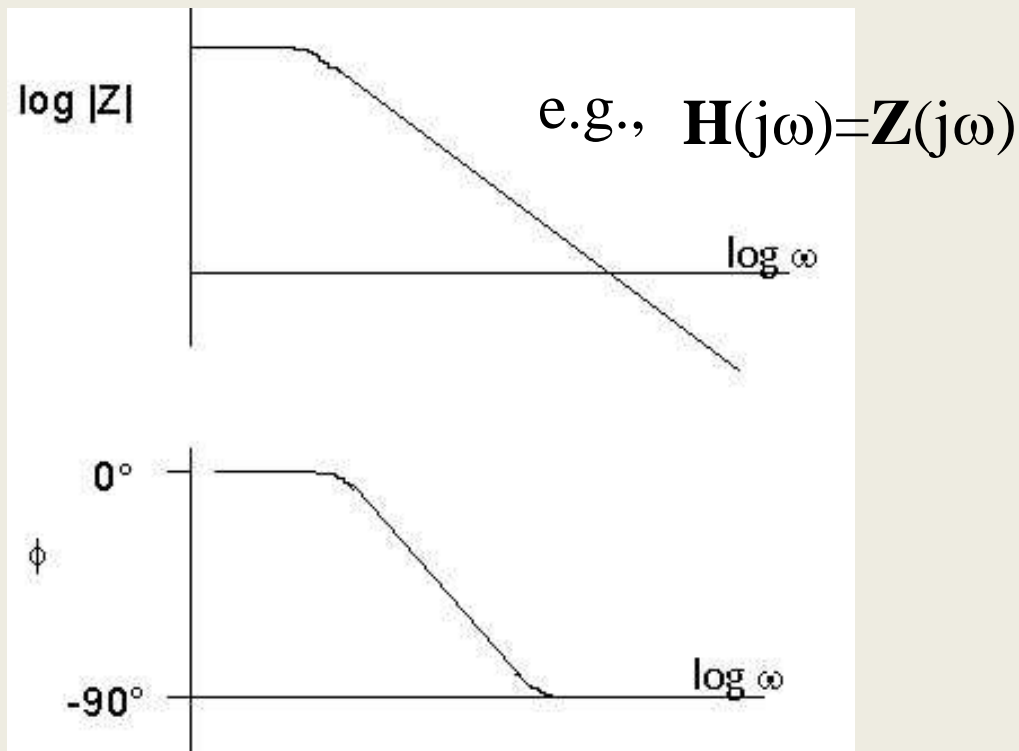

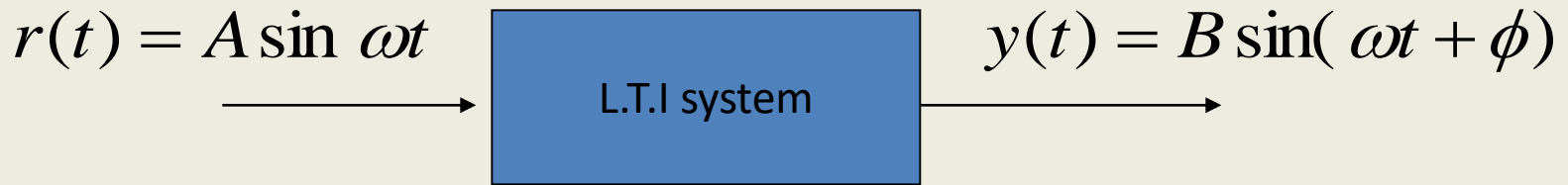

Magnitude: $\frac{B}{A}$ Phase: ϕ

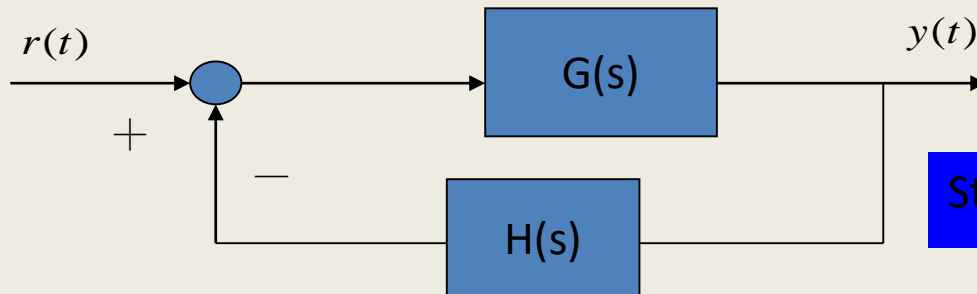

Steady state response

$$\frac{Y(s)}{R(s)} = \frac{G(s)}{1 + G(s)H(s)}$$

$$s = \sigma + j\omega \Rightarrow s = j\omega$$

Magnitude:

$$\frac{|G(j\omega)|}{|1 + G(j\omega)H(j\omega)|}$$

Phase:

$$\frac{\angle G(j\omega)}{\angle [1 + G(j\omega)H(j\omega)]}$$

Logarithmic coordinate

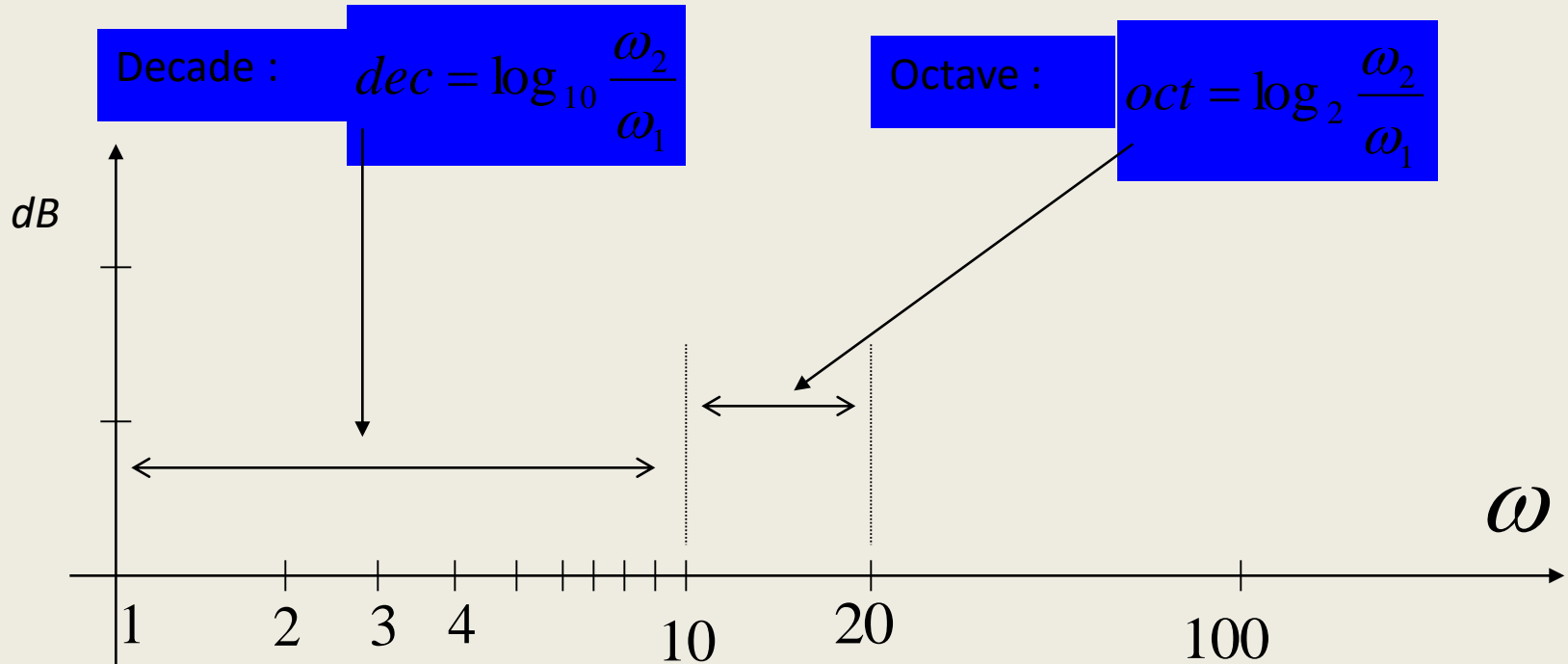

- The gain magnitude is many times expressed in terms of decibels (dB)

$$dB = 20 \log_{10} A$$

where A is the amplitude or gain

- a *decade* is defined as any 10-to-1 frequency range
- an *octave* is any 2-to-1 frequency range

$$20 \text{ dB/decade} = 6 \text{ dB/octave}$$

Bode Plot Construction

$$\frac{Y(s)}{R(s)} = \frac{k(s + z_1)(s + z_2)\cdots}{(s + p_1)(s + p_2)(s^2 + as + b)\cdots}$$

Case 1: k

Magnitude:

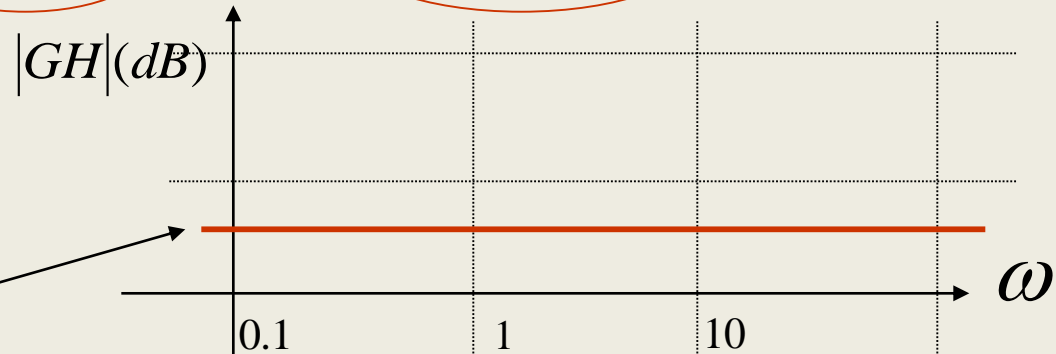

$$|k|_{dB} = 20 \log |k| (dB)$$

Phase:

$$\angle k = \begin{cases} 0^\circ & , k > 0 \\ 180^\circ & , k < 0 \end{cases}$$

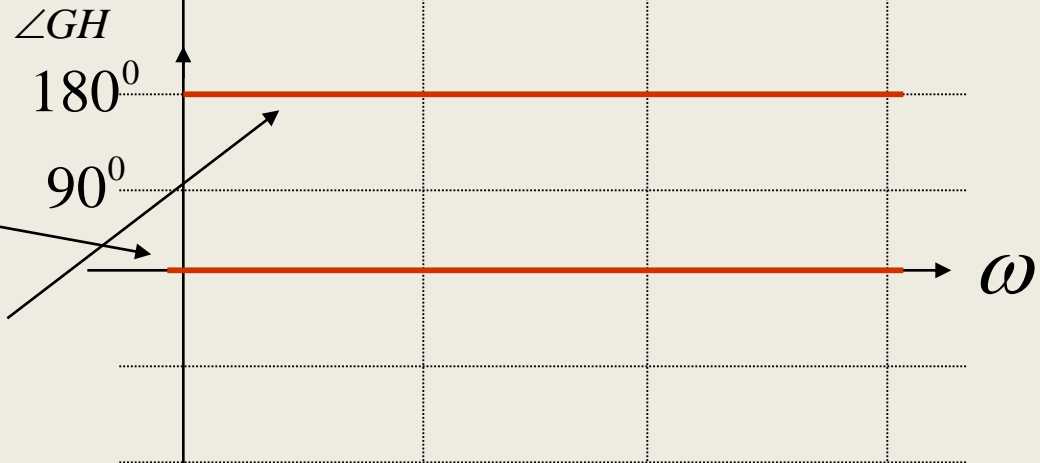

Case II : $\frac{1}{s^p}$

Magnitude:

$$\left| \frac{1}{(j\omega)^p} \right|_{dB} = -20p \log \omega (dB)$$

Phase:

$$\angle \frac{1}{(j\omega)^p} = (-90^\circ) \times p$$

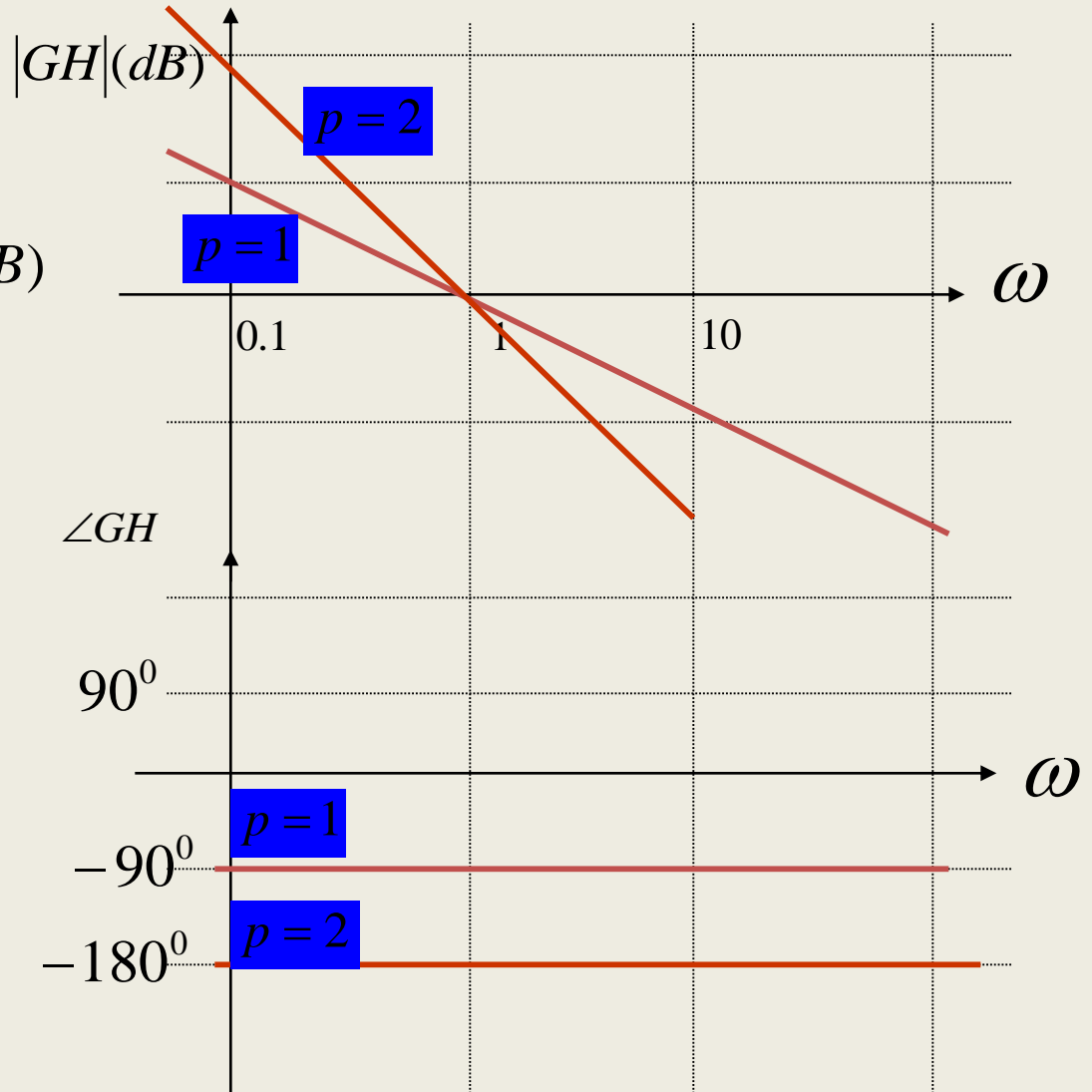

Case III :

$$S^p$$

Magnitude:

$$\left| (j\omega)^p \right|_{dB} = 20p \log \omega (dB)$$

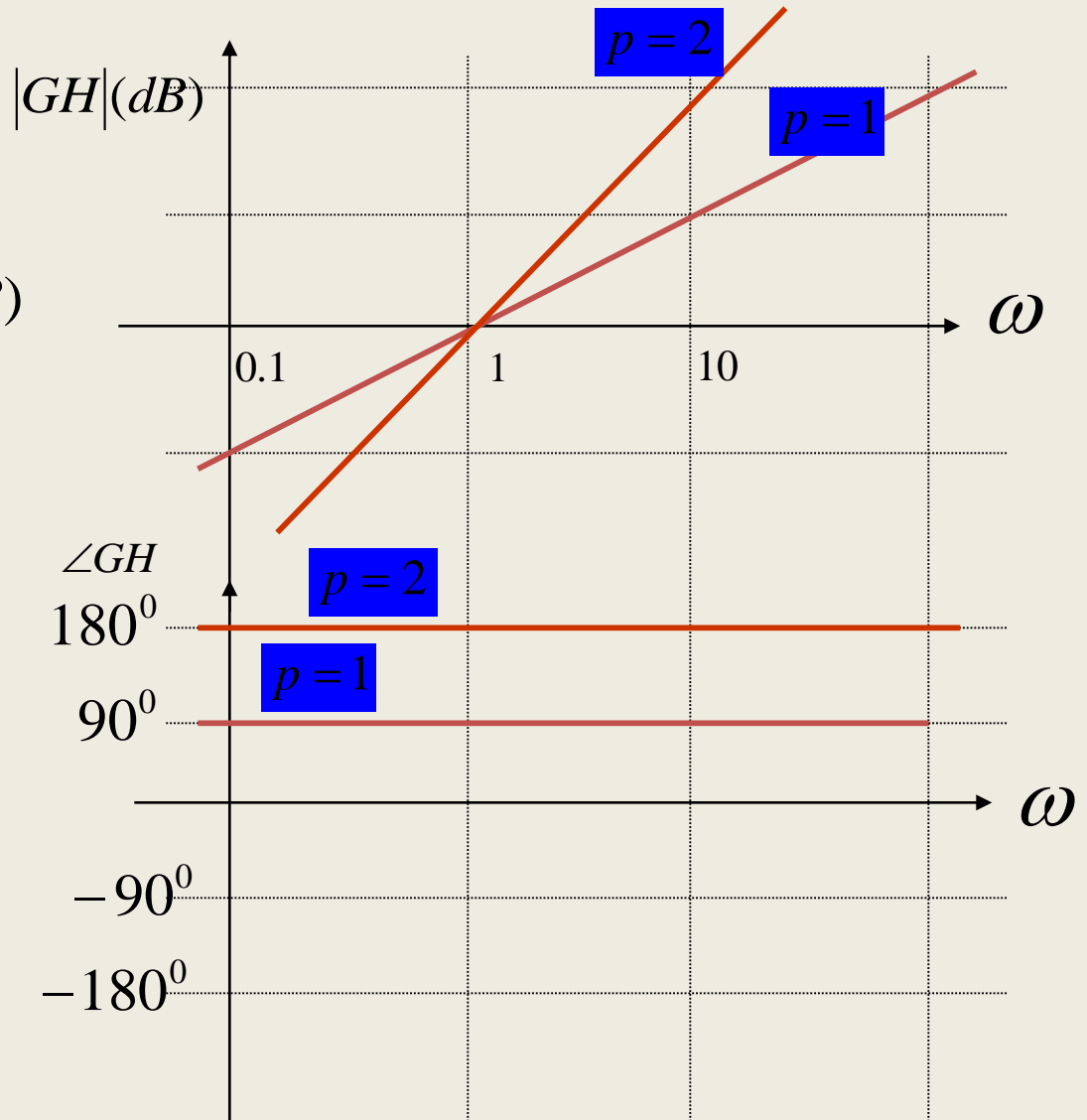

Phase:

$$\angle (j\omega)^p = (90^\circ) \times p$$

Case IV: $\frac{a}{(s+a)}$ or $(\frac{1}{a}s+1)^{-1}$

$a=1$

Magnitude:

$$\left| (1 + j\frac{\omega}{a})^{-1} \right|_{dB} = -20 \log \sqrt{1 + (\frac{\omega}{a})^2}$$

$$= -10 \log [1 + (\frac{\omega}{a})^2]$$

$$\omega \ll a \Rightarrow \frac{\omega}{a} \approx 0 \Rightarrow dB = -10 \log 1 = 0$$

$$\omega \gg a \Rightarrow 1 + j\frac{\omega}{a} \approx \frac{\omega}{a} \Rightarrow dB \approx -20 \log \frac{\omega}{a}$$

$$dB = -[20 \log \omega - 20 \log a]$$

$$\omega = a \Rightarrow 1 + j1 \Rightarrow dB = -10 \log 2 = -3.01$$

Phase:

$$\angle(1 + j\frac{\omega}{a}) = 0^\circ - \tan^{-1} \frac{\omega}{a}$$

$$\omega \ll a \Rightarrow \frac{\omega}{a} \approx 0 \Rightarrow \angle GH \approx \tan^{-1} 0 = 0^\circ$$

$$\omega \gg a \Rightarrow \frac{\omega}{a} \approx \infty \Rightarrow \angle GH \approx -\tan^{-1} \infty = -90^\circ$$

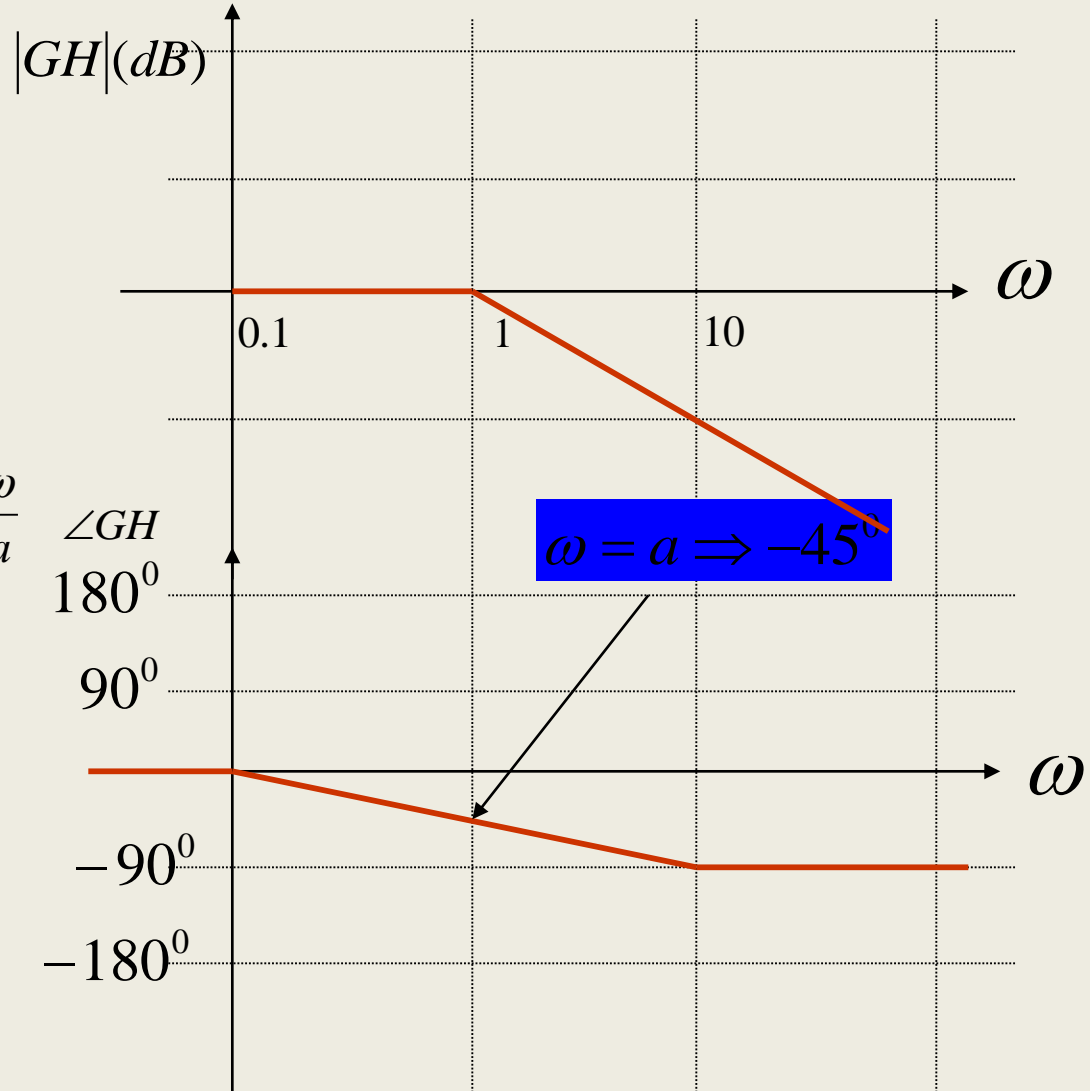

Case V:

$$\frac{(s+a)}{a} \text{ or } \left(\frac{1}{a}s+1\right)$$

$$a=1$$

Magnitude:

$$\left|1 + j\frac{\omega}{a}\right|_{dB} = 20 \log \sqrt{1 + \left(\frac{\omega}{a}\right)^2}$$

$$= 10 \log \left[1 + \left(\frac{\omega}{a}\right)^2\right]$$

$$\omega \ll a \Rightarrow \frac{\omega}{a} \approx 0 \Rightarrow dB = 10 \log 1 = 0$$

$$\omega \gg a \Rightarrow 1 + j\frac{\omega}{a} \approx \frac{\omega}{a} \Rightarrow dB \approx 20 \log \frac{\omega}{a}$$

$$dB = 20 \log \omega - 20 \log a$$

$$\omega = a \Rightarrow 1 + j1 \Rightarrow dB = 10 \log 2 = 3.01$$

Phase:

$$\angle\left(1 + j\frac{\omega}{a}\right) = \tan^{-1} \frac{\omega}{a}$$

$$\omega \ll a \Rightarrow \frac{\omega}{a} \approx 0 \Rightarrow \angle GH \approx \tan^{-1} 0 = 0^\circ$$

$$\omega \gg a \Rightarrow \frac{\omega}{a} \approx \infty \Rightarrow \angle GH \approx \tan^{-1} \infty = 90^\circ$$

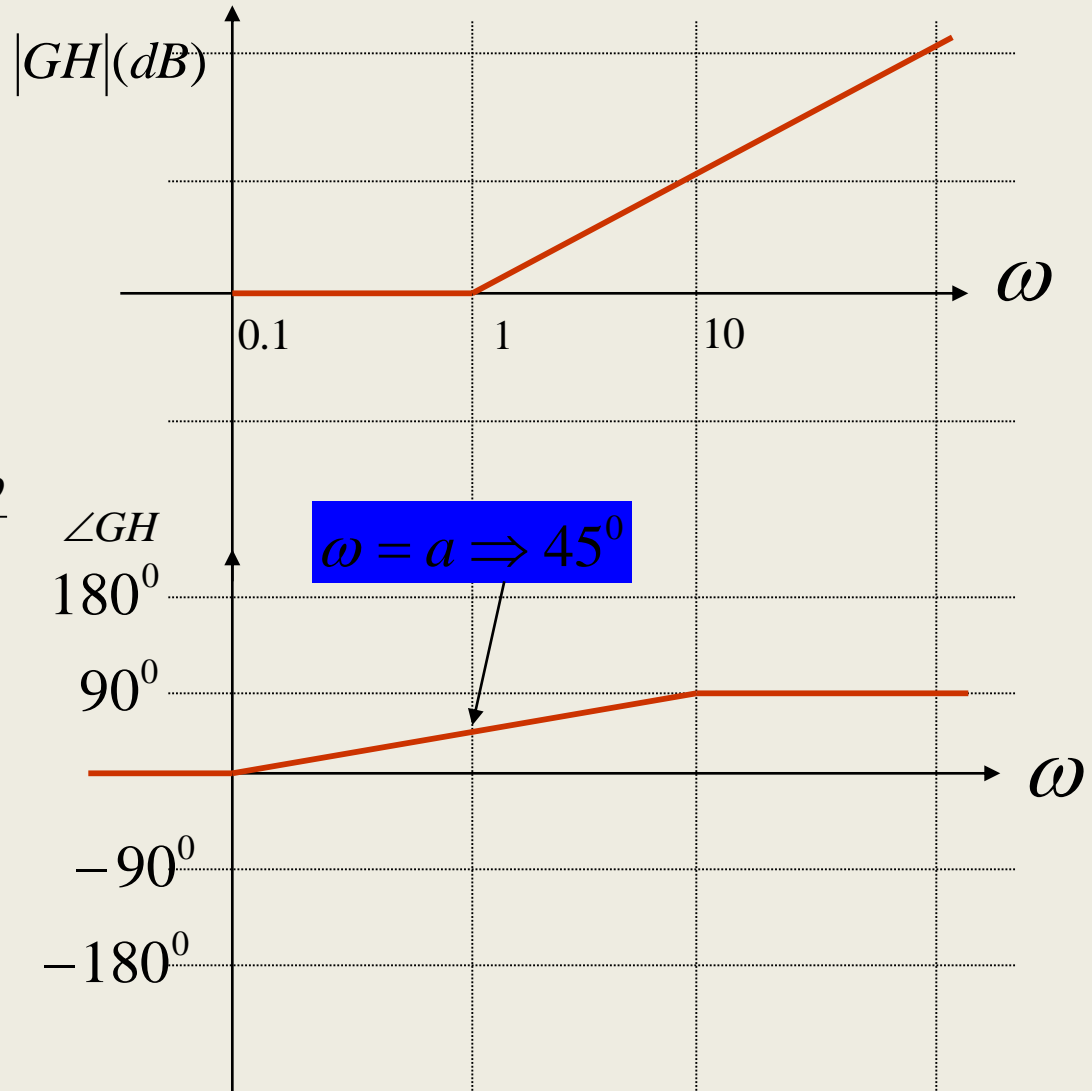

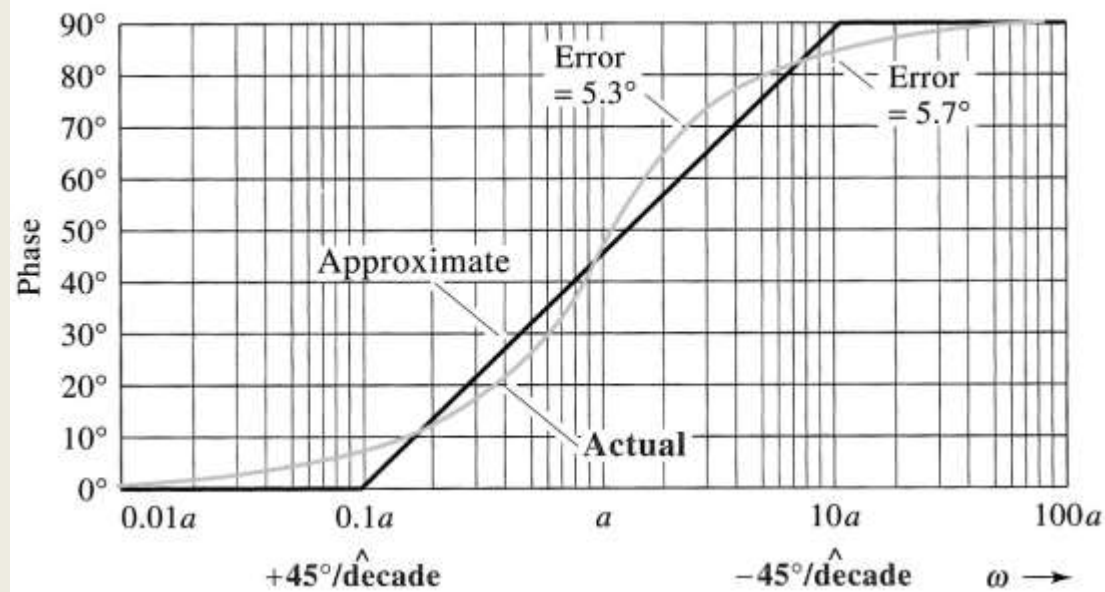
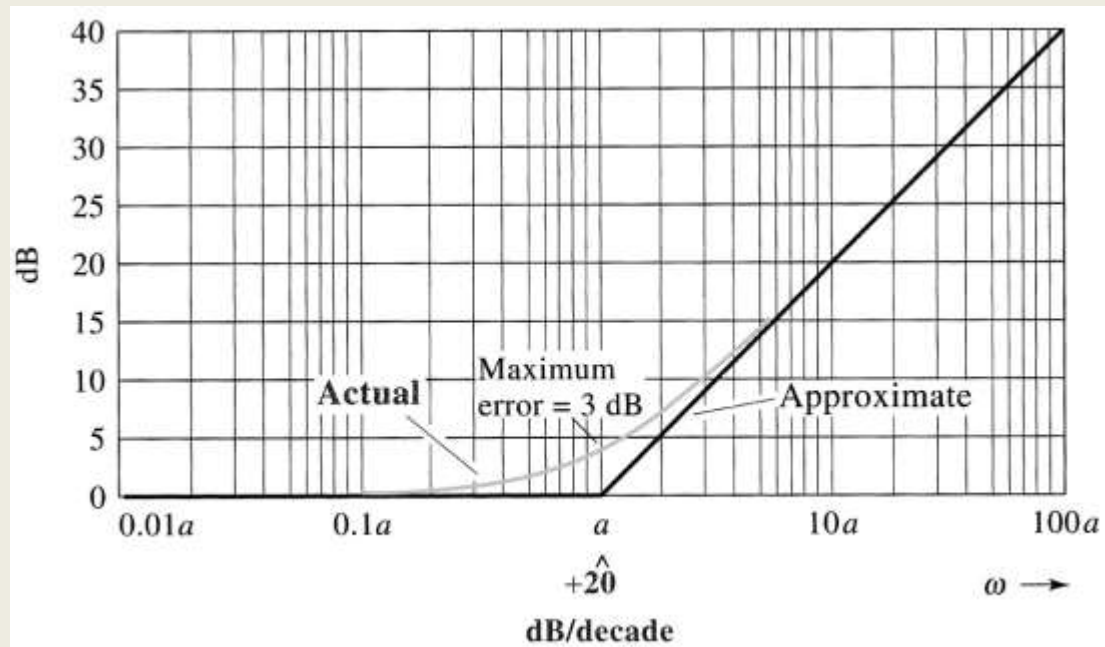

Case VI:

$$T(s) = \frac{\omega_n^2}{s^2 + 2\xi\omega_n s + \omega_n^2}$$

$$T(j\omega) = \frac{\omega_n^2}{(\omega_n^2 - \omega^2) + 2j\xi\omega_n\omega} \quad \angle T(j\omega) = -\tan^{-1} \frac{2\xi\omega\omega_n}{(\omega_n^2 - \omega^2)}$$

$$T(j\omega) = \frac{1}{(1 - (\frac{\omega}{\omega_n})^2) + j2\xi\frac{\omega}{\omega_n}} \quad \angle T(j\omega) = -\tan^{-1} \frac{2\xi\frac{\omega}{\omega_n}}{1 - (\frac{\omega}{\omega_n})^2}$$

$$|T(j\omega)| = \begin{cases} 0 & , \frac{\omega}{\omega_n} \ll 1 \\ -20 \log(2\xi) & , \frac{\omega}{\omega_n} = 1 \\ -40 \log(\frac{\omega}{\omega_n}) & , \frac{\omega}{\omega_n} \gg 1 \end{cases} \quad \angle T(j\omega) = \begin{cases} 0^0 & , \frac{\omega}{\omega_n} \ll 1 \\ -90^0 & , \frac{\omega}{\omega_n} = 1 \\ -180^0 & , \frac{\omega}{\omega_n} \gg 1 \end{cases}$$

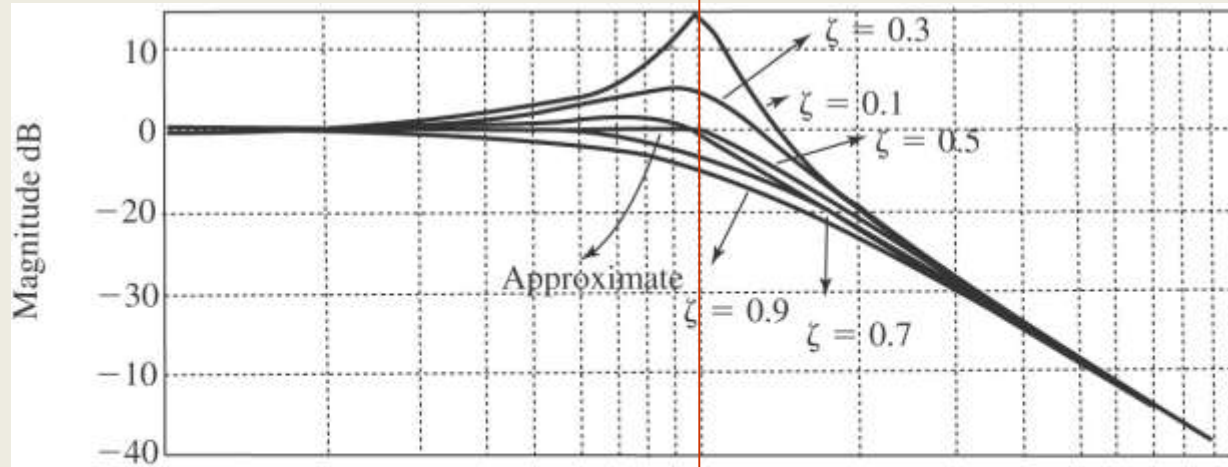

$\omega = \omega_n$

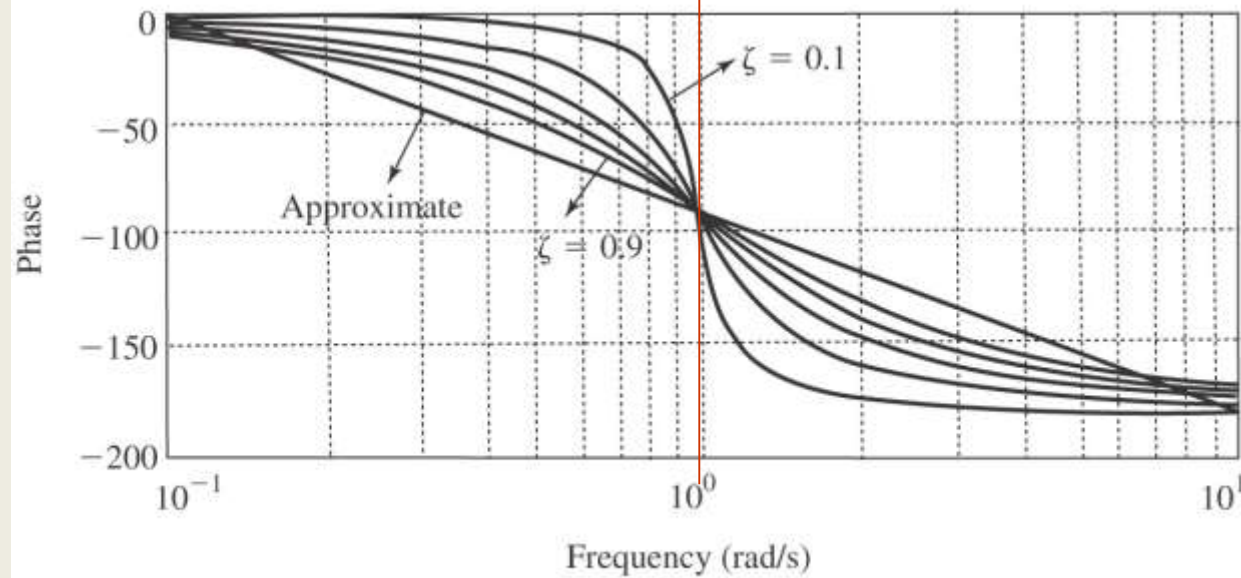

Relative Stability

A transfer function is called **minimum phase** when all the poles and zeroes are LHP and **non-minimum-phase** when there are RHP poles or zeroes.

Minimum phase system



Stable

The **gain margin (GM)** is the distance on the bode magnitude plot from the amplitude at the phase crossover frequency up to the 0 dB point. $GM = -(dB \text{ of } GH \text{ measured at the phase crossover frequency})$

The **phase margin (PM)** is the distance from -180 up to the phase at the gain crossover frequency. $PM = 180 + \text{phase of } GH \text{ measured at the gain crossover frequency}$

Open loop transfer function : $G(s)H(s)$

Closed-loop transfer function : $1 + G(s)H(s)$

Open loop Stability \rightarrow poles of $G(s)H(s)$ in LHP

Closed-loop Stability \rightarrow
poles of $G(s)H(s)$ in left side of $(-1,0)$

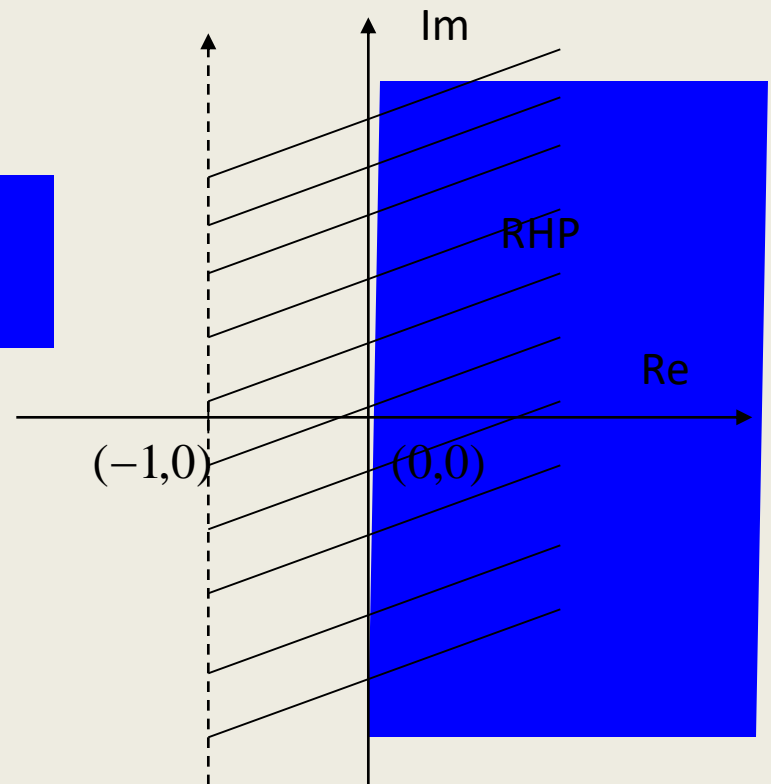

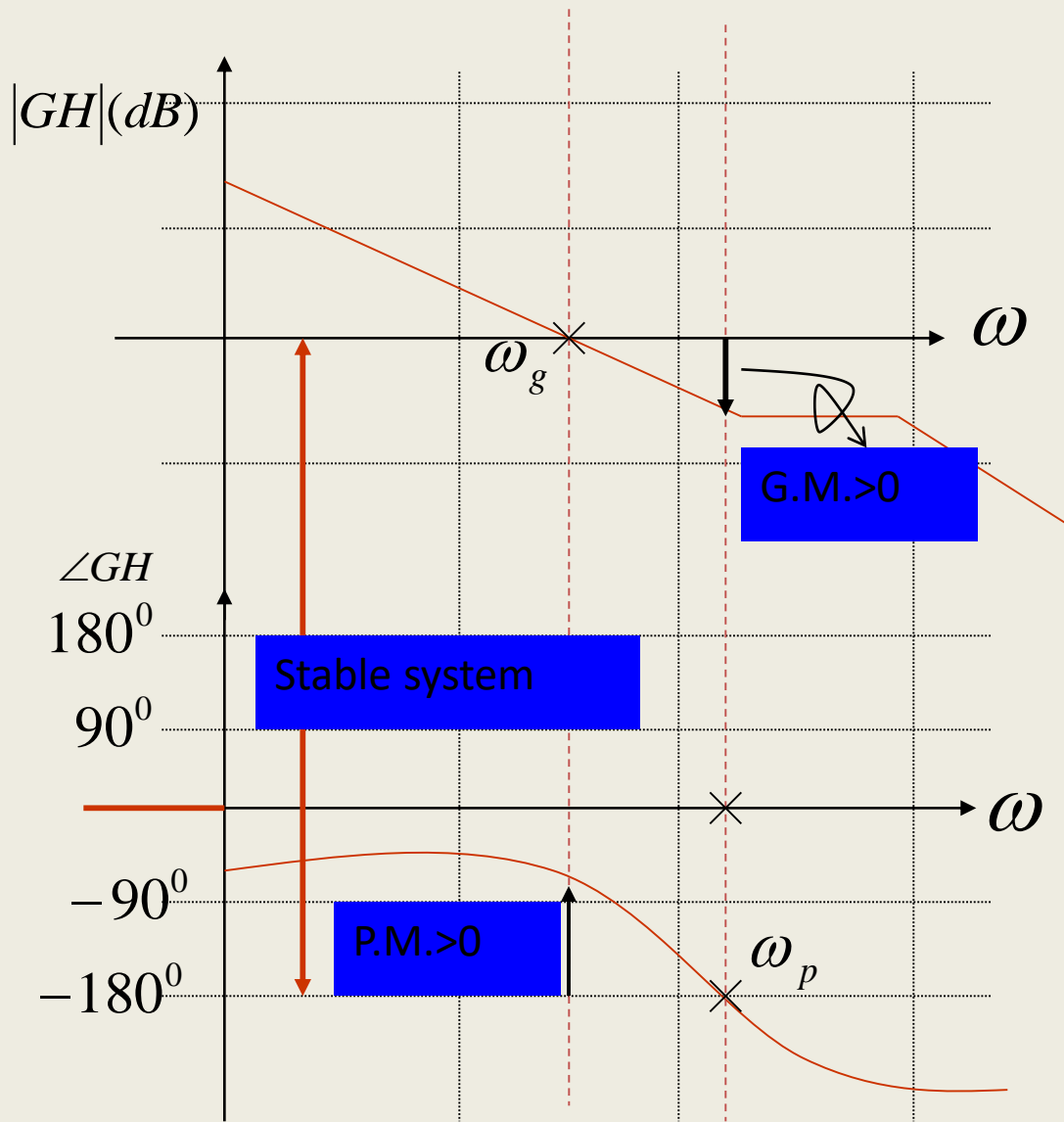

$$(-1,0) \Rightarrow \begin{cases} 0dB \\ -180^\circ \end{cases}$$

Gain crossover frequency: ω_g

phase crossover frequency: ω_p

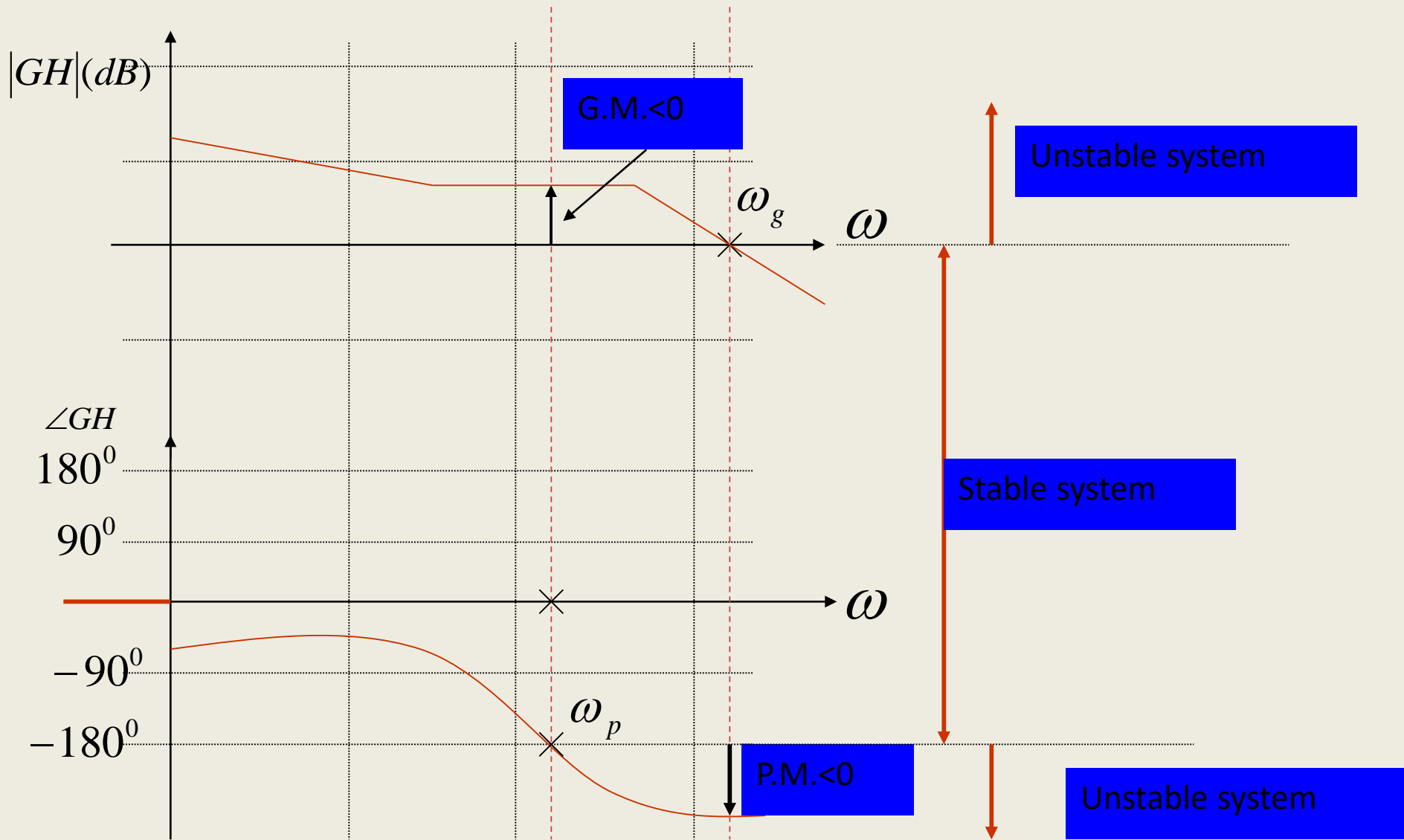

Bode Diagrams

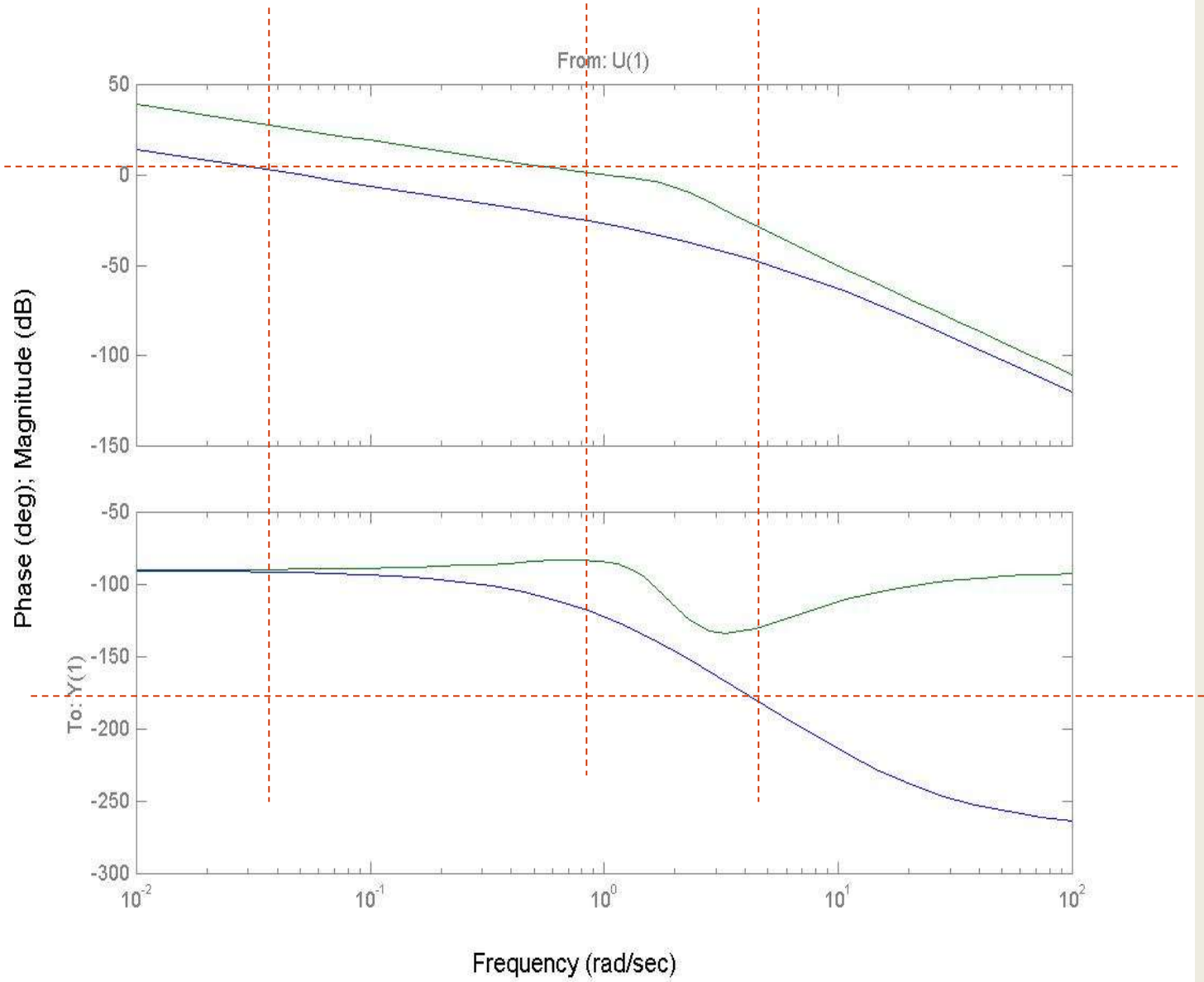

Gain and Phase Margin

Let's say that we have the following system:

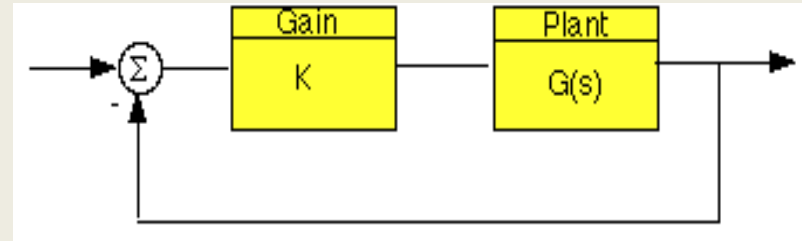

where K is a variable (constant) gain and $G(s)$ is the plant under consideration.

The gain margin is defined as the change in open loop gain required to make the system unstable. Systems with greater gain margins can withstand greater changes in system parameters before becoming unstable in closed loop. Keep in mind that unity gain in magnitude is equal to a gain of zero in dB

The phase margin is defined as the change in open loop phase shift required to make a closed loop system unstable.

The phase margin is the difference in phase between the phase curve and -180 deg at the point corresponding to the frequency that gives us a gain of 0 dB (the gain cross over frequency, ω_{gc}).

Likewise, the gain margin is the difference between the magnitude curve and 0 dB at the point corresponding to the frequency that gives us a phase of -180 deg (the phase cross over frequency, ω_{pc}).

Gain and Phase Margin

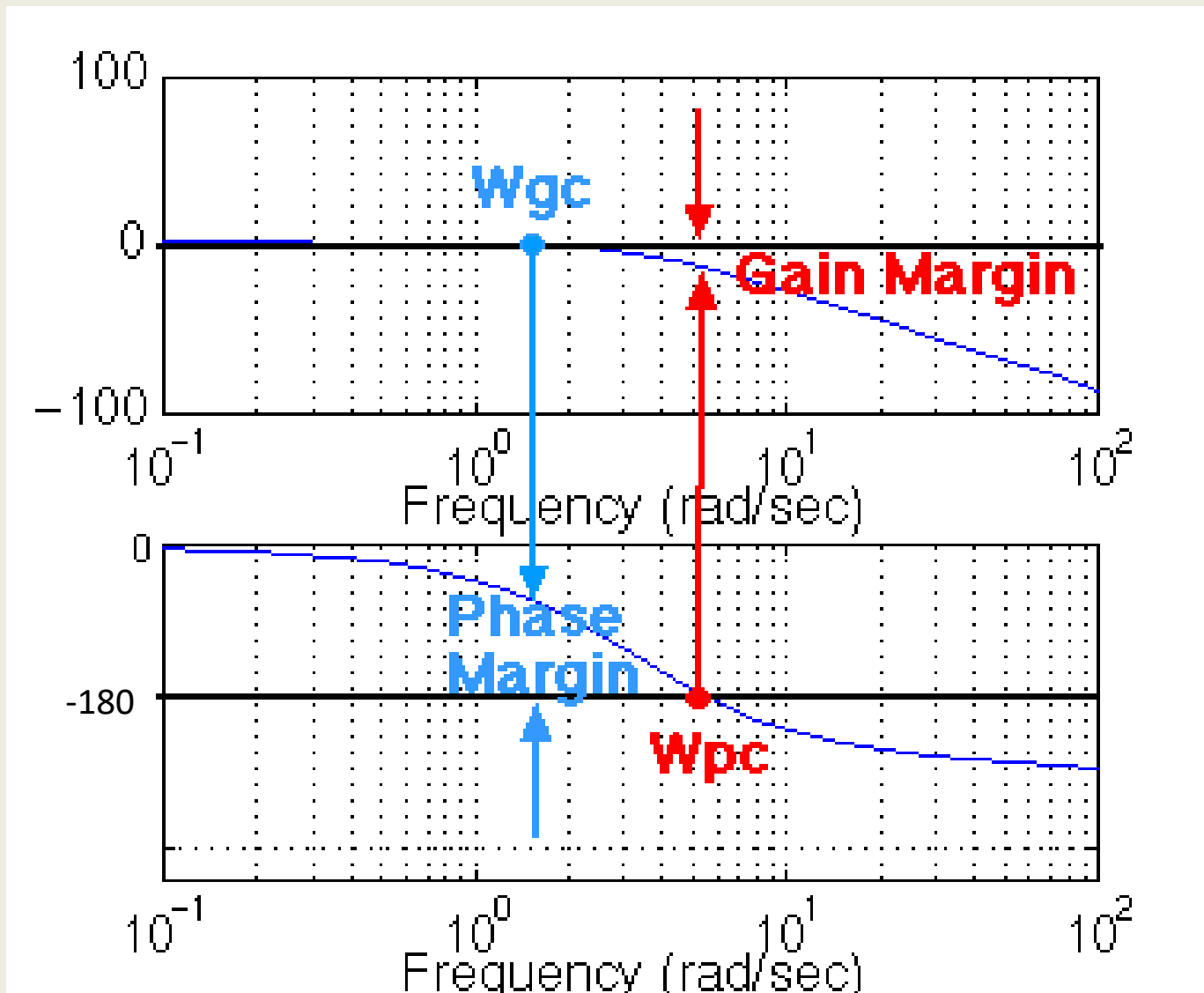

Polar plot

The polar form of $G(j\omega)H(j\omega)$ is-

$$G(j\omega)H(j\omega) = |G(j\omega)H(j\omega)| \angle G(j\omega)H(j\omega)$$

The **Polar plot** is a plot, which can be drawn between the magnitude and the phase angle of $G(j\omega)H(j\omega)$ by varying ω from zero to ∞ . The polar graph sheet or in a regular graph sheet is shown in the following figure.

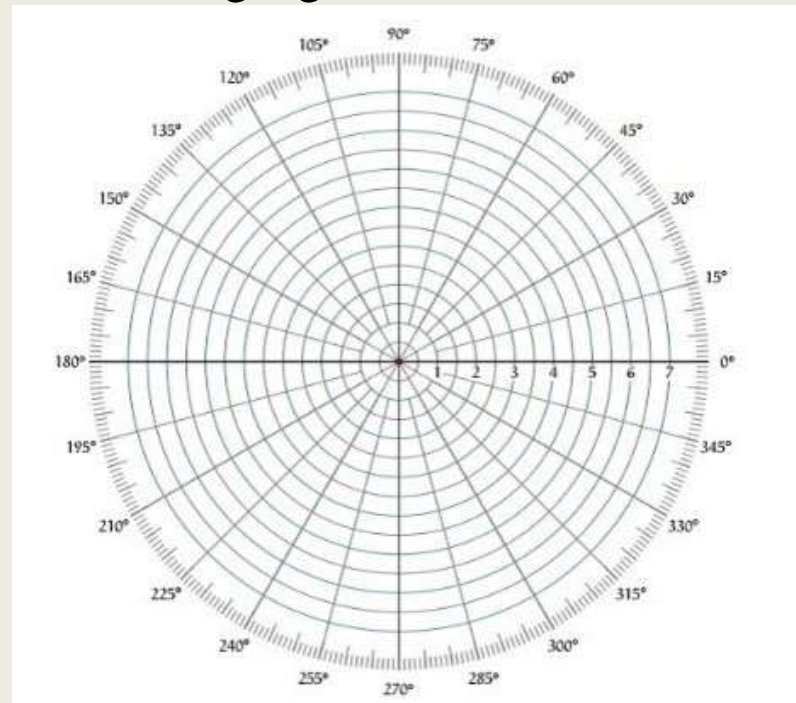

Rules for Drawing Polar Plots:

Follow these rules for plotting the polar plots.

- Substitute, $s=j\omega$ in the open loop transfer function.
- Write the expressions for magnitude and the phase of $G(j\omega)H(j\omega)$.
- Find the starting magnitude and the phase of $G(j\omega)H(j\omega)$ by substituting $\omega=0$.

So, the polar plot starts with this magnitude and the phase angle.

- Find the ending magnitude and the phase of $G(j\omega)H(j\omega)$ by substituting $\omega=\infty$.

So, the polar plot ends with this magnitude and the phase angle.

- Check whether the polar plot intersects the real axis, by making the imaginary term of $G(j\omega)H(j\omega)$ equal to zero and find the value(s) of ω .
- Check whether the polar plot intersects the imaginary axis, by making real term of $G(j\omega)H(j\omega)$ equal to zero and find the value(s) of ω .
- For drawing polar plot more clearly, find the magnitude and phase of $G(j\omega)H(j\omega)$ by considering the other value(s) of ω

Example

Consider a first order system

$$G(s) = \frac{1}{1 + \tau s}$$

where τ is the time constant.

Step 1 –Substitute, $s=j\omega$ in the first order system.

$$G(j\omega) = \frac{1}{1 + j\omega\tau}$$

Multiplying both numerator and denominator by the conjugate of

$$G(j\omega) = \frac{1 - j\omega\tau}{1 + \omega^2\tau^2} = \underbrace{\frac{1}{1 + \omega^2\tau^2}}_{\text{Re}(G(j\omega))} + j \underbrace{\frac{-\omega\tau}{1 + \omega^2\tau^2}}_{\text{Im}(G(j\omega))}$$

Step 2 -The magnitude of the transfer function is

$$|G(j\omega)| = \sqrt{\left(\frac{1}{1+\omega^2\tau^2}\right)^2 + \left(\frac{-\omega\tau}{1+\omega^2\tau^2}\right)^2} = \frac{1}{\sqrt{1+\omega^2\tau^2}}$$

Step 3--The phase angle of the transfer function is

$$\phi = \tan^{-1}\left(\frac{-\omega\tau / (1+\omega^2\tau^2)}{1 / (1+\omega^2\tau^2)}\right) = \tan^{-1}\left(\frac{-\omega\tau}{1}\right)$$

Step 4

Point	Frequency (w)	Magnitude	Phase angle
1	0	1	0
2	∞	0	-90

Point 3 Where the plot crosses the real axis, i.e., $\text{Im}(G(j\omega)) = 0$.

$$\frac{-\omega\tau}{1+\omega^2\tau^2} = 0 \Rightarrow \omega = 0 \text{ and } \omega = \infty. \text{ These are the same as Points 1 and 2.}$$

Point 4 Where the plot crosses the imaginary axis, $\text{Re}(G(j\omega)) = 0$.

$$\frac{1}{1+\omega^2\tau^2} = 0 \Rightarrow \omega = \infty. \text{ This is the same as Point 2.}$$

For one more frequency point: Taking $\omega = 1/\tau$, then one has

$$|G(j\omega)| = \frac{1}{\sqrt{1+1}} = \frac{1}{\sqrt{2}}, \quad \phi = \tan^{-1}\left(\frac{-1}{1}\right) = -45^\circ$$

Sketching the Polar plot for $\frac{1}{(1 + \tau s)}$, one has

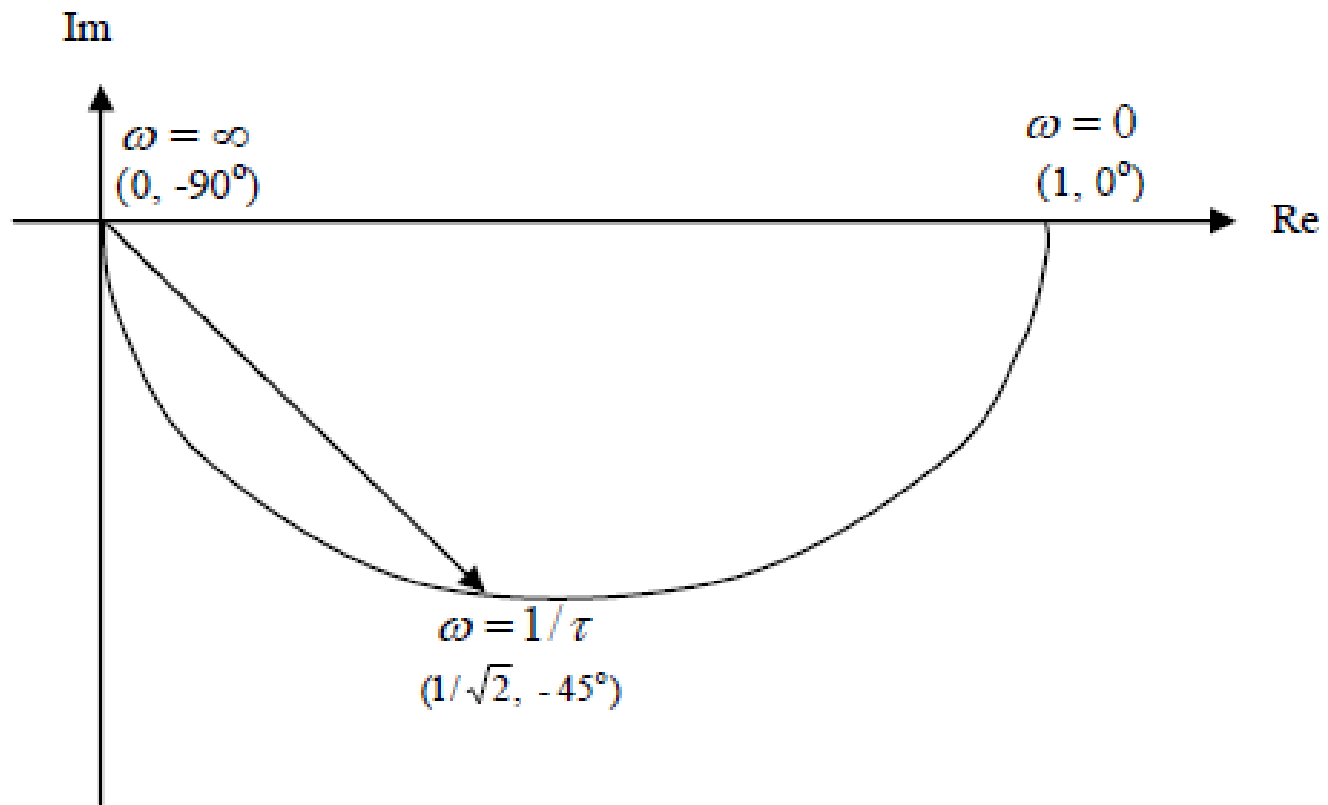

Example

$$G(s) = \frac{K}{(1+sT_1)(1+sT_2)}$$

Putting $s = j\omega$, we get

$$G(j\omega) = \frac{K}{(1+j\omega T_1)(1+j\omega T_2)}$$

$$|G(j\omega)| = \frac{K}{\sqrt{1+\omega^2 T_1^2} \sqrt{1+\omega^2 T_2^2}}$$

$$\angle G(j\omega) = -\tan^{-1}(\omega T_1) - \tan^{-1}(\omega T_2)$$

$$\text{For } \omega = 0, |G(j\omega)| = K, \angle G(j\omega) = 0^\circ$$

$$\text{For } \omega = \infty, |G(j\omega)| = 0, \angle G(j\omega) = -180^\circ$$

To find out the points on which the plot cuts real and/or imaginary axis, we derive

$$\begin{aligned}
 G(j\omega) &= \frac{K}{(1+j\omega T_1)(1+j\omega T_2)} \frac{(1-j\omega T_1)(1-j\omega T_2)}{(1-j\omega T_1)(1-j\omega T_2)} \\
 &= \frac{K(1-j\omega T_1-j\omega T_2-\omega^2(T_1 T_2))}{(1+\omega^2 T_1^2)(1+\omega^2 T_2^2)} \\
 &= \frac{K(1-\omega^2 T_1 T_2)}{(1+\omega^2 T_1^2)(1+\omega^2 T_2^2)} + j \frac{(-K\omega(T_1+T_2))}{(1+\omega^2 T_1^2)(1+\omega^2 T_2^2)}
 \end{aligned}$$

If we put real part to zero, then

$$1 - \omega^2 T_1 T_2 = 0$$

$$\omega = \frac{1}{\sqrt{T_1 T_2}}$$

Putting this value in $G(j\omega)$, we get negative imaginary value, hence the plot is cutting on negative imaginary axis.

Putting imaginary part to zero, we get $= 0$; hence the plot does not cut real axis.

Value at which plot cuts negative imaginary axis,

$$A = |G(j\omega)|_{\omega = \frac{1}{\sqrt{T_1 T_2}}} = \frac{K\sqrt{T_1 T_2}}{T_1 + T_2} \text{ (derive it yourself)}$$

The system in question will have polar plot as,

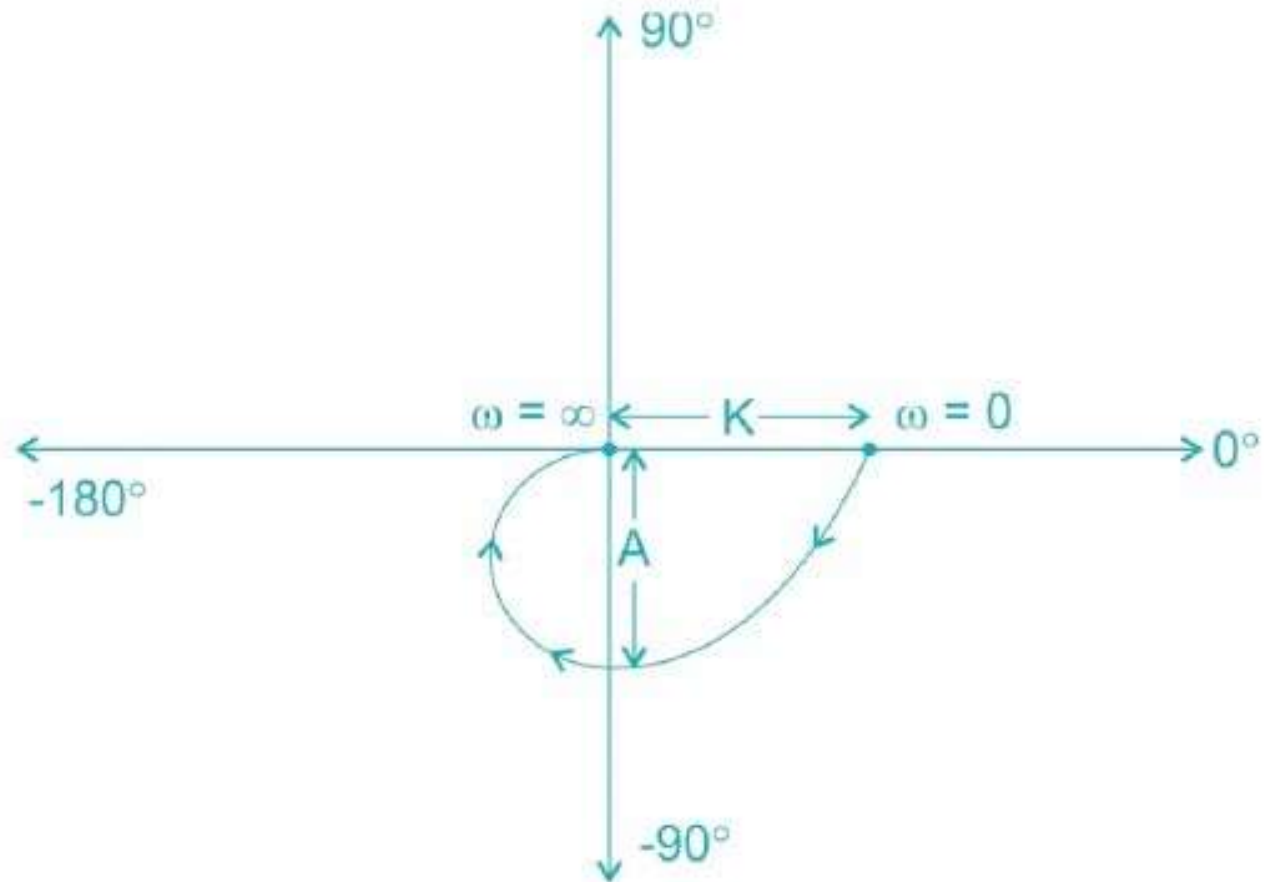

Compensator

- The control system are designed to perform specific tasks. The requirement of a control system are usually specified as performance specifications.
- The specifications related to accuracy, relative stability and speed of the response.

The design problem may be stated as follows:

- **When a set of specifications are given for a system, then a suitable compensator should be designed so that the overall system will meet the given specification.**
- The compensation schemes used for feedback control system is **either series compensation** or **parallel** feedback compensation.

Realization of lag compensator using electrical network:

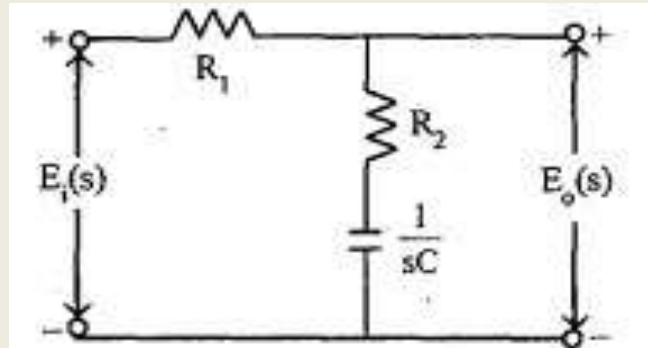

$$E_o(s) = E_i(s) \frac{(R_2 + 1/sC)}{(R_1 + R_2 + 1/sC)} = E_i(s) \frac{(sCR_2 + 1) / sC}{[sC(R_1 + R_2) + 1] / sC}$$
$$= E_i(s) \frac{(sCR_2 + 1)}{[sC(R_1 + R_2) + 1]}$$

Transfer function of electrical network

$$\left. \begin{array}{l} \text{Transfer function} \\ \text{of electrical network} \end{array} \right\} \frac{E_o(s)}{E_i(s)} = \frac{CR_2(s + 1/CR_2)}{C(R_1 + R_2)[s + 1/C(R_1 + R_2)]}$$

Realization of lead compensator using electrical network:

By voltage division rule,

$$\text{Output voltage, } E_0(s) = E_i(s) \frac{R_2}{R_2 + \left(R_1 \times \frac{1}{sC} \right)}$$

$$E_0(s) = E_i(s) \cdot \frac{R_2}{R_2 + \frac{R_1}{(R_1Cs + 1)}}$$

$$= E_i(s) \frac{R_2}{\frac{R_2(R_1Cs + 1) + R_1}{R_1Cs + 1}}$$

$$\text{Transfer function of electrical network } \left\{ \frac{E_0(s)}{E_i(s)} = \frac{R_2(R_1Cs + 1)}{[R_1R_2Cs + R_2 + R_1]} = \frac{R_1CR_2 \left[s + \frac{1}{R_1C} \right]}{R_1CR_2 \left[s + \frac{(R_1 + R_2)}{R_1CR_2} \right]} \right.$$

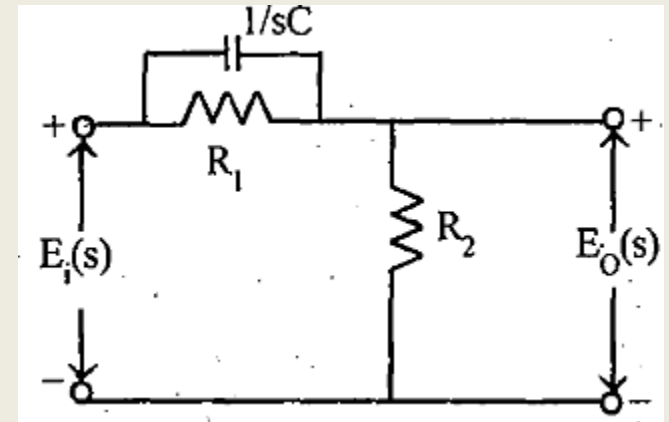

S. No	Lag Compensator	Lead Compensator	Lag-Lead compensator
1	A compensator having the characteristics of a lag network is called lag compensator.	A compensator having the characteristics of a lead network is called lead compensator.	A compensator having the characteristics of a lag-lead network is called lag-lead compensator.
2	If a sinusoidal signal is applied, then in steady state the output will have a phase lag with respect to the input.	If a sinusoidal signal is applied, then in steady state the output will have a phase lead with respect to the input.	If a sinusoidal signal is applied, then in steady state both phase lag and lead occurs in the output, but in different frequency region.
3	Lag compensation results in a large improvement in steady state performance but results in slower response due to reduced bandwidth.	The lead compensation increases the bandwidth, which improves the speed of the response and also reduces the amount of overshoot.	A lag-lead compensation combines the advantages of lag and lead compensations.

UNIT V STATE SPACE ANALYSIS **OF CONTINUOUS SYSTEMS**

- Alternative method of modeling a system than
 - Differential / difference equations
 - Transfer functions
- Uses matrices and vectors to represent the system parameters and variables

Motivation for State-Space Modeling

- Easier for computers to perform matrix algebra
 - e.g. MATLAB does all computations as matrix math
- Handles multiple inputs and outputs
- Provides more information about the system
 - Provides knowledge of internal variables (states)

⇒ Primarily used in complicated, large-scale systems

Transfer Functions vs. State-Space Models

- Transfer functions provide only input and output behavior
 - No knowledge of the inner workings of the system
 - System is essentially a “black box” that performs some functions

- State-space models also represent the internal behavior of the system

Definitions

V – Input vector

- Can be multiple inputs
- Written as a column vector

$$v(t) = \begin{bmatrix} v_1(t) \\ v_2(t) \\ \vdots \\ v_R(t) \end{bmatrix}$$

Y – Output vector

- A function of the input and the present state of the internal variables

$$y(t) = \begin{bmatrix} y_1(t) \\ y_2(t) \\ \vdots \\ y_M(t) \end{bmatrix}$$

Definitions

X – State vector

- Information of the current condition of the internal variables
- N is the “dimension” of the state model (number of internal state variables)

\dot{X} – “Next state” vector

- Derivative of the state vector
- Provides knowledge of where the states are going
 - Direction (+ or -)
 - How fast (magnitude)
- A function f of the input and the present state of the internal variables

DEFINITIONS

State:- The state of a dynamic system is the smallest set of variables (called state variables) that must be known at any given instant in order that, the future response of the system to any specified input may be calculated from the given dynamic equation. These are the set of variables such that the knowledge of these variables at $t=t_0$, together with the input for $t \geq t_0$ completely determines the behaviour of the systems for any time $t \geq t_0$.

DEFINITIONS

State Variables: The state variables of a dynamic system are the smallest set of variables which determine the state of the dynamic system. If at least n variables $x_1(t), x_2(t), \dots, x_n(t)$ are needed to completely describe the behaviour of a dynamic system (such that once the input is given for $t \geq t_0$ and the initial state at $t = t_0$ is specified, the future state of the system is completely determined), then such n variables $x_1(t), x_2(t), \dots, x_n(t)$ are a set of variables called STATE variables. It can also be noticed that the state variables need not be physically measurable or observable quantities. Practically, however, it is convenient to choose easily measurable quantities for the state variables because optimal control laws will require the feedback of all state variables with suitable weight.

State Space The n -dimensional space whose coordinate axes consist of the x_1 axis, x_2 axis, x_n axis is called a state space. Any state can be represented by a point in the state space.

State-Space Equations

General form of the state-space model

Two equations – $\dot{x}(t)$
 $y(t)$

$$\dot{x}(t) = f(x(t), v(t), t)$$

$$y(t) = g(x(t), v(t), t)$$

Linear State-Space Equations

$$\dot{x}(t) = Ax(t) + Bv(t)$$

$$y(t) = Cx(t) + Dv(t)$$

$x(t)$, $\dot{x}(t) \rightarrow N \times 1$ vectors

$v(t) \rightarrow R \times 1$ vector

$y(t) \rightarrow M \times 1$ vector

$A \rightarrow N \times N$ system matrix

$B \rightarrow N \times R$ input matrix

$C \rightarrow M \times N$ output matrix

$D \rightarrow M \times R$ matrix representing direct coupling from system inputs to system outputs

If A , B , C , D are constant over time, then the system is also time invariant

→ Linear Time Invariant (LTI) system

Construction of State Equations from a Differential Equation

(Let there be no derivatives of the input)

- The dimension of the state equations (number of state variables) should equal the order of the differential equation
- Let one state variable equal the output ($y(t)$)
- Let one state variable equal the derivative of the output
- Let one state variable equal the $(N-1)$ -th derivative of the output (where N is the order of the differential equation)
- Find the derivative of each of the newly defined state equations
 - In terms of the other state variables and the outputs
- Write the state equations

The State Variables of a Dynamic System:

The time-domain analysis and design of control systems utilizes the concept of the state of a system.

The state of a system is a set of variables such that the knowledge of these variables and the input functions will, with the equations describing the dynamics, provide the future state and output of the system.

For a dynamic system, the state of a system is described in terms of a set of state variables

$$[x_1(t) \quad x_2(t) \quad \dots \quad x_n(t)]$$

The state variables are those variables that determine the future behavior of a system when the present state of the system and the excitation signals are known. Consider the system shown in Figure 1, where $y_1(t)$ and $y_2(t)$ are the output signals and $u_1(t)$ and $u_2(t)$ are the input signals. A set of state variables $[x_1 \ x_2 \ \dots \ x_n]$ for the system shown in the figure is a set such that knowledge of the initial values of the state variables $[x_1(t_0) \ x_2(t_0) \ \dots \ x_n(t_0)]$ at the initial time t_0 , and of the input signals $u_1(t)$ and $u_2(t)$ for $t \geq t_0$, suffices to determine the future values of the outputs and state variables.

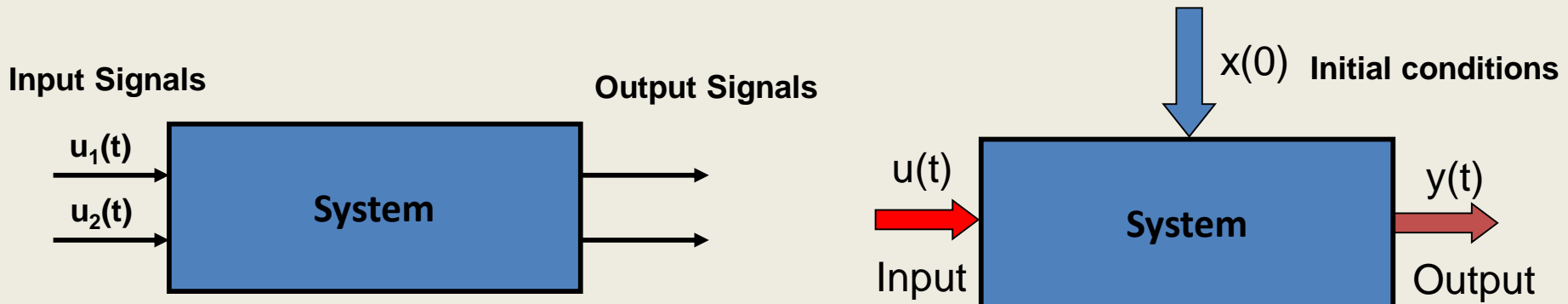

The state variables describe the future response of a system, given the present state, the excitation inputs, and the equations describing the dynamics.

A simple example of a state variable is the state of an on-off light switch. The switch can be in either the on or the off position, and thus the state of the switch can assume one of two possible values. Thus, if we know the present state (position) of the switch at t_0 and if an input is applied, we are able to determine the future value of the state of the element.

The concept of a set of state variables that represent a dynamic system can be illustrated in terms of the spring-mass-damper system shown in Figure 2. The number of state variables chosen to represent this system should be as small as possible in order to avoid redundant state variables. A set of state variables sufficient to describe this system includes the position and the velocity of the mass.

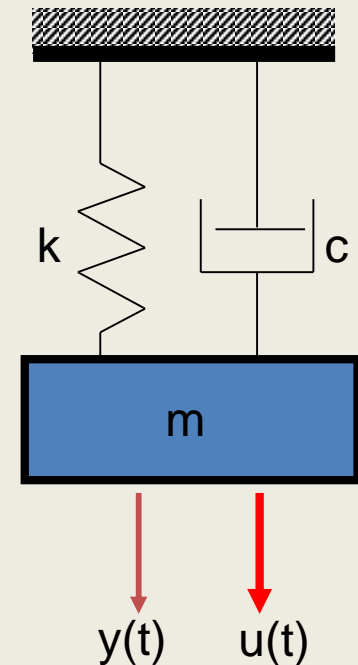

The State Differential Equation:

The state of a system is described by the set of first-order differential equations written in terms of the state variables $[x_1 \ x_2 \ \dots \ x_n]$. These first-order differential equations can be written in general form as

$$\begin{aligned}\dot{x}_1 &= a_{11}x_1 + a_{12}x_2 + \dots a_{1n}x_n + b_{11}u_1 + \dots b_{1m}u_m \\ \dot{x}_2 &= a_{21}x_1 + a_{22}x_2 + \dots a_{2n}x_n + b_{21}u_1 + \dots b_{2m}u_m \\ &\vdots \\ \dot{x}_n &= a_{n1}x_1 + a_{n2}x_2 + \dots a_{nn}x_n + b_{n1}u_1 + \dots b_{nm}u_m\end{aligned}$$

Thus, this set of simultaneous differential equations can be written in matrix form as follows:

$$\frac{d}{dt} \begin{bmatrix} x_1 \\ x_2 \\ \vdots \\ x_n \end{bmatrix} = \begin{bmatrix} a_{11} & a_{12} & \cdots & a_{1n} \\ a_{21} & a_{22} & \cdots & a_{2n} \\ \vdots & \cdots & \cdots & \vdots \\ a_{n1} & a_{n2} & \cdots & a_{nn} \end{bmatrix} \begin{bmatrix} x_1 \\ x_2 \\ \vdots \\ x_n \end{bmatrix} + \begin{bmatrix} b_{11} & \cdots & b_{1m} \\ \vdots & \cdots & \vdots \\ b_{n1} & \cdots & b_{nm} \end{bmatrix} \begin{bmatrix} u_1 \\ \vdots \\ u_m \end{bmatrix}$$

n: number of state variables, m: number of inputs.

The column matrix consisting of the state variables is called the **state vector** and is written as

$$\mathbf{x} = \begin{bmatrix} x_1 \\ x_2 \\ \vdots \\ x_n \end{bmatrix}$$

The vector of input signals is defined as u . Then the system can be represented by the compact notation of the state differential equation as

$$\dot{\mathbf{x}} = \mathbf{A} \mathbf{x} + \mathbf{B} \mathbf{u}$$

This differential equation is also commonly called the state equation. The matrix \mathbf{A} is an $n \times n$ square matrix, and \mathbf{B} is an $n \times m$ matrix. The state differential equation relates the rate of change of the state of the system to the state of the system and the input signals. In general, the outputs of a linear system can be related to the state variables and the input signals by the output equation

$$\mathbf{y} = \mathbf{C} \mathbf{x} + \mathbf{D} \mathbf{u}$$

Where \mathbf{y} is the set of output signals expressed in column vector form. The state-space representation (or state-variable representation) is comprised of the state variable differential equation and the output equation.

We can write the state variable differential equation for the RLC circuit as

$$\dot{\mathbf{x}} = \begin{bmatrix} 0 & -\frac{1}{C} \\ \frac{1}{L} & -\frac{R}{L} \end{bmatrix} \mathbf{x} + \begin{bmatrix} 1 \\ 0 \end{bmatrix} u(t)$$

and the output as

$$y = [0 \quad R] \mathbf{x}$$

The solution of the state differential equation can be obtained in a manner similar to the approach we utilize for solving a first order differential equation. Consider the first-order differential equation

$$\dot{x} = ax + bu$$

Where $x(t)$ and $u(t)$ are scalar functions of time. We expect an exponential solution of the form e^{at} . Taking the Laplace transform of both sides, we have

$$s \mathbf{X}(s) - \mathbf{x}_0 = \mathbf{a} \mathbf{X}(s) + \mathbf{b} \mathbf{U}(s)$$

therefore,

$$\mathbf{X}(s) = \frac{\mathbf{x}(0)}{s - \mathbf{a}} + \frac{\mathbf{b}}{s - \mathbf{a}} \mathbf{U}(s)$$

The inverse Laplace transform of $\mathbf{X}(s)$ results in the solution

$$\mathbf{x}(t) = e^{\mathbf{a}t} \mathbf{x}(0) + \int_0^t e^{\mathbf{a}(t-\tau)} \mathbf{b} u(\tau) d\tau$$

We expect the solution of the state differential equation to be similar to $\mathbf{x}(t)$ and to be of differential form. The **matrix exponential function** is defined as

$$e^{\mathbf{A}t} = \mathbf{I} + \mathbf{A}t + \frac{\mathbf{A}^2 t^2}{2!} + \dots + \frac{\mathbf{A}^k t^k}{k!} + \dots$$

which converges for all finite t and any A . Then the solution of the state differential equation is found to be

$$\mathbf{x}(t) = e^{At} \mathbf{x}(0) + \int_0^t e^{A(t-\tau)} \mathbf{B} \mathbf{u}(\tau) d\tau$$

$$\mathbf{X}(s) = [s\mathbf{I} - \mathbf{A}]^{-1} \mathbf{x}(0) + [s\mathbf{I} - \mathbf{A}]^{-1} \mathbf{B} \mathbf{U}(s)$$

where we note that $[s\mathbf{I} - \mathbf{A}]^{-1} = \phi(s)$, which is the Laplace transform of $\phi(t) = e^{At}$. The matrix exponential function $\phi(t)$ describes the unforced response of the system and is called the fundamental or **state transition matrix**.

$$\mathbf{x}(t) = \phi(t) \mathbf{x}(0) + \int_0^t \phi(t - \tau) \mathbf{B} \mathbf{u}(\tau) d\tau$$

THE TRANSFER FUNCTION FROM THE STATE EQUATION

The transfer function of a single input-single output (SISO) system can be obtained from the state variable equations.

$$\dot{\mathbf{x}} = \mathbf{A} \mathbf{x} + \mathbf{B} u$$
$$\mathbf{y} = \mathbf{C} \mathbf{x}$$

where y is the single output and u is the single input. The Laplace transform of the equations

$$s\mathbf{X}(s) = \mathbf{A}\mathbf{X}(s) + \mathbf{B} U(s)$$
$$\mathbf{Y}(s) = \mathbf{C}\mathbf{X}(s)$$

where \mathbf{B} is an $n \times 1$ matrix, since u is a single input. We do not include initial conditions, since we seek the transfer function. Reordering the equation

$$[s\mathbf{I} - \mathbf{A}]\mathbf{X}(s) = \mathbf{B} \mathbf{U}(s)$$

$$\mathbf{X}(s) = [s\mathbf{I} - \mathbf{A}]^{-1} \mathbf{B} \mathbf{U}(s) = \phi(s) \mathbf{B} \mathbf{U}(s)$$

$$\mathbf{Y}(s) = \mathbf{C} \phi(s) \mathbf{B} \mathbf{U}(s)$$

Therefore, the transfer function $G(s)=Y(s)/U(s)$ is

$$\mathbf{G}(s) = \mathbf{C} \phi(s) \mathbf{B}$$

Example:

Determine the transfer function $G(s)=Y(s)/U(s)$ for the RLC circuit as described by the state differential function

$$\dot{\mathbf{x}} = \begin{bmatrix} 0 & -\frac{1}{C} \\ \frac{1}{L} & -\frac{R}{L} \end{bmatrix} \mathbf{x} + \begin{bmatrix} \frac{1}{C} \\ 0 \end{bmatrix} u \quad , \quad y = [0 \quad R] \mathbf{x}$$

$$[sI - A] = \begin{bmatrix} s & \frac{1}{C} \\ -\frac{1}{L} & s + \frac{R}{L} \end{bmatrix}$$

$$\phi(s) = [sI - A]^{-1} = \frac{1}{\Delta(s)} \begin{bmatrix} s + \frac{R}{L} & -\frac{1}{C} \\ \frac{1}{L} & s \end{bmatrix}$$

$$\Delta(s) = s^2 + \frac{R}{L}s + \frac{1}{LC}$$

Then the transfer function is

$$G(s) = \begin{bmatrix} 0 & R \end{bmatrix} \begin{bmatrix} \frac{s + \frac{R}{L}}{\Delta(s)} & -\frac{1}{C\Delta(s)} \\ \frac{1}{L\Delta(s)} & \frac{s}{\Delta(s)} \end{bmatrix} \begin{bmatrix} \frac{1}{C} \\ 0 \end{bmatrix}$$

$$G(s) = \frac{R/LC}{\Delta(s)} = \frac{R/LC}{s^2 + \frac{R}{L}s + \frac{1}{LC}}$$

State transition matrix

$$\frac{d}{dt} x(t) = Ax(t) + Bu(t)$$
$$y(t) = Cx(t) + Du(t)$$

The behavior of $x(t)$ et $y(t)$:

1. Homogeneous solution of $x(t)$
2. Non-homogeneous solution of $x(t)$

Homogeneous solution

$$\dot{x}(t) = Ax(t)$$

$$sX(s) - x(0) = AX(s)$$

$$X(s) = (sI - A)^{-1} x(0)$$

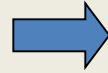

$$\begin{aligned} x(t) &= L^{-1}[(sI - A)^{-1}]x(0) \\ &= e^{At} x(0) \end{aligned}$$

State transition matrix

$$\Phi(t) \stackrel{\Delta}{=} e^{At} = L^{-1}[(sI - A)^{-1}]$$

$$x(t_0) = e^{At_0} x(0)$$

$$x(0) = e^{-At_0} x(t_0)$$

$$x(t) = e^{At} e^{-At_0} x(t_0) = e^{A(t-t_0)} x(t_0) = \Phi(t - t_0) x(t_0)$$

Properties

$$\Phi(t) \stackrel{\Delta}{=} e^{At} = L^{-1}[(sI - A)^{-1}]$$

1. $\Phi(0) = I$
2. $\Phi^{-1}(t) = \Phi(-t)$
3. $x(0) = \Phi(-t)x(t)$
4. $\Phi(t_2 - t_1)\Phi(t_1 - t_0) = \Phi(t_2 - t_0)$
5. $\Phi(t)^k = \Phi(kt)$

Non-homogeneous solution

$$\frac{d}{dt} x(t) = Ax(t) + Bu(t)$$

$$y(t) = Cx(t) + Du(t)$$

$$sX(s) - x(0) = AX(s) + BU(s)$$

$$(sI - A)X(s) = x(0) + BU(s)$$

$$X(s) = (sI - A)^{-1} x(0) + (sI - A)^{-1} BU(s)$$

$$x(t) = L^{-1}[(sI - A)^{-1}]x(0) + L^{-1}[(sI - A)^{-1} BU(s)]$$

$$x(t) = \Phi(t)x(0) + \int_0^t \Phi(t - \tau)Bu(\tau)d\tau$$

$$x(t) = \Phi(t)x(0) + \int_0^t \Phi(t - \tau)Bu(\tau)d\tau$$

$$x(t) = \Phi(t - t_0)x(t_0) + \int_{t_0}^t \Phi(t - \tau)Bu(\tau)d\tau$$

$$y(t) = C\Phi(t - t_0)x(t_0) + \int_{t_0}^t C\Phi(t - \tau)Bu(\tau)d\tau + Du(t)$$



Zero-input response



Zero-state response

Example 1

$$\begin{bmatrix} \dot{x}_1 \\ \dot{x}_2 \end{bmatrix} = \begin{bmatrix} 0 & 1 \\ -2 & -3 \end{bmatrix} \begin{bmatrix} x_1 \\ x_2 \end{bmatrix} + \begin{bmatrix} 0 \\ 1 \end{bmatrix} u(t)$$

$$\text{let } x(0) = \begin{bmatrix} 0 & 0 \end{bmatrix}^T$$

$$\Phi(t) = L^{-1}[(sI - A)^{-1}] = e^{At} = \begin{bmatrix} 2e^{-t} - e^{-2t} & e^{-t} - e^{-2t} \\ -2e^{-t} + 2e^{-2t} & -e^{-t} + 2e^{-2t} \end{bmatrix}$$

$$x(t) = \Phi(t)x(0) + \int_0^t \Phi(t-\tau)Bu(\tau)d\tau$$

Ans:

$$\begin{bmatrix} x_1 \\ x_2 \end{bmatrix} = \begin{bmatrix} \frac{1}{2} + 2e^{-t} - \frac{3}{2}e^{-2t} \\ -2e^{-t} + 2e^{-2t} \end{bmatrix}$$

$$L^{-1}[(sI - A)^{-1}BU(s)]$$

$$\Phi(t) = L^{-1}[(sI - A)^{-1}]$$

$$\begin{bmatrix} \dot{x}_1 \\ \dot{x}_2 \\ \dot{x}_3 \end{bmatrix} = \begin{bmatrix} 0 & 1 & 0 \\ 0 & -4 & 3 \\ -1 & -1 & -2 \end{bmatrix} \begin{bmatrix} x_1 \\ x_2 \\ x_3 \end{bmatrix} + \begin{bmatrix} 0 & 0 \\ 1 & 0 \\ 0 & 1 \end{bmatrix} \begin{bmatrix} u_1 \\ u_2 \end{bmatrix}$$

$$\begin{bmatrix} y_1(t) \\ y_2(t) \end{bmatrix} = \begin{bmatrix} 1 & 0 & 0 \\ 0 & 0 & 1 \end{bmatrix} \begin{bmatrix} x_1 \\ x_2 \\ x_3 \end{bmatrix}$$

$$(sI - A)^{-1} = \frac{\text{adj}(sI - A)}{|sI - A|}$$

$$= \frac{1}{s(s+4)(s+2)+3+3s} \begin{bmatrix} s^2 + 6s + 11 & s + 2 & 3 \\ -3 & s^2 + 2 & 3s \\ s + 4 & -s - 1 & s^2 + 4s \end{bmatrix}$$