



# FUNDAMENTALS OF ELECTRICAL CIRCUITS (20A02101T)

---

1

► **PREPARED BY**

**Dr.S.Mallikarjunaiah**

**Professor,**

**Department of EEE.**

**VEMU Institute of Technology**

**JAWAHARLAL NEHRU TECHNOLOGICAL UNIVERSITY ANANTAPUR**  
**B.Tech (EEE) – I Sem L T P C (3 0 0 3)**  
**(20A02101T) FUNDAMENTALS OF ELECTRICAL CIRCUITS**

**Course Objectives:**

To make the student learn about

- Basic characteristics of R, L, C parameters, their Voltage and Current Relations and Various combinations of these parameters.
- The Single Phase AC circuits and concepts of real power, reactive power, complex power, phase angle and phase difference
- Series and parallel resonances, bandwidth, current locus diagrams
- Network theorems and their applications
- Network Topology and concepts like Tree, Cut-set , Tie-set, Loop, Co-Tree

**Unit- 1**

**Introduction to Electrical & Magnetic Circuits**

Electrical Circuits: Circuit Concept – Types of elements - Source Transformation-Voltage – Current Relationship for Passive Elements. Kirchhoff's Laws – Network Reduction Techniques- Series, Parallel, Series Parallel, Star-to-Delta or Delta-to-Star Transformation. Examples Magnetic Circuits: Faraday's Laws of Electromagnetic Induction-Concept of Self and Mutual Inductance-Dot Convention-Coefficient of Coupling-Composite Magnetic Circuit-Analysis of Series and Parallel Magnetic Circuits, MMF Calculations.

**Unit- 2**

**Network Topology**

Definitions – Graph – Tree, Basic Cutset and Basic Tieset Matrices for Planar Networks – Loop and Nodal Methods of Analysis of Networks & Independent Voltage and Current Sources – Duality & Dual Networks.Nodal Analysis, Mesh Analysis.

**Unit- 3**

**Single Phase A.C Circuits**

R.M.S, Average Values and Form Factor for Different Periodic Wave Forms – Sinusoidal Alternating Quantities – Phase and Phase Difference – Complex and Polar Forms of Representations, j-Notation, Steady State Analysis of R, L and C (In Series, Parallel and Series Parallel Combinations) with Sinusoidal Excitation- Resonance - Phasor diagrams - Concept of Power Factor- Concept of Reactance, Impedance, Susceptance and Admittance-Apparent Power, Active and Reactive Power, Examples.

## **Unit- 4**

### **Network Theorems**

Superposition, Reciprocity, Thevenin's, Norton's, Maximum Power Transfer, Millmann's, Tellegen's, and Compensation Theorems for D.C and Sinusoidal Excitations.

## **Unit- 5**

### **Three Phase A.C. Circuits**

Introduction - Analysis of Balanced Three Phase Circuits – Phase Sequence- Star and Delta Connection -Relation between Line and Phase Voltages and Currents in Balanced Systems - Measurement of Active and Reactive Power in Balanced and Unbalanced Three Phase Systems. Analysis of Three Phase Unbalanced Circuits - Loop Method - Star Delta Transformation Technique – for balanced and unbalanced circuits - Measurement of Active and reactive Power – Advantages of Three Phase System.

#### **Text Books:**

1. Fundamentals of Electric Circuits Charles K. Alexander and Matthew. N. O. Sadiku, Mc Graw Hill, 5th Edition, 2013.
2. Engineering circuit analysis William Hayt and Jack E. Kemmerly, Mc Graw Hill Company, 7th Edition, 2006.

#### **Reference Books:**

1. Circuit Theory Analysis & Synthesis A. Chakrabarti, Dhanpat Rai & Sons, 7th Revised Edition, 2018.
2. Network Analysis M.E Van Valkenberg, Prentice Hall (India), 3rd Edition, 1999.
3. Electrical Engineering Fundamentals V. Del Toro, Prentice Hall International, 2nd Edition, 2019.
4. Electric Circuits- Schaum's Series, Mc Graw Hill, 5th Edition, 2010.
5. Electrical Circuit Theory and Technology John Bird, Routledge, Taylor & Francis, 5th Edition, 2014.

## COURSE OUTCOMES

After completing the course, the student should be able to do the following

- Given a network, find the equivalent impedance by using network reduction techniques and determine the current through any element and voltage across and power through any element.
- Given a circuit and the excitation, determine the real power, reactive power, power factor etc,.
- Apply the network theorems suitably
- Determine the Dual of the Network, develop the Cut Set and Tie-set Matrices for a given Circuit. Also understand various basic definitions and concepts

# UNIT - 1

## Electric Circuit

- The system in which **electric current** can flow from source to load through one path and after delivering energy at load, the current can return to the other terminal of source through another path is referred as electric circuit.

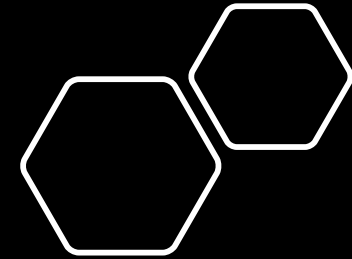

## Main Parts of an Electric Circuit

- Electrical Sources (for delivering electricity to the circuit and these are mainly electric generators and batteries)
- Controlling Devices (for controlling electricity and these are mainly switches, circuit breakers, **MCBs** etc.)
- Protection Devices (for protecting the circuit from abnormal conditions and these are mainly **electric fuses**, **MCBs**, Switchgear systems)
- Conducting Path (to carry current one point to other in the circuit and these are mainly wires or conductors)
- Load

# Basic Properties of an Electric Circuit

- A circuit is always a closed path.
- A circuit always contain an energy source which acts as source of electrons.
- The electric elements include uncontrolled and controlled source of energy, resistors, **capacitors**, **inductors**, etc.
- In an **electric circuit** flow of electrons takes place from negative terminal to positive terminal.
- Direction of flow of conventional current is from positive to negative terminal.
- Flow of current leads to potential drop across the various elements.

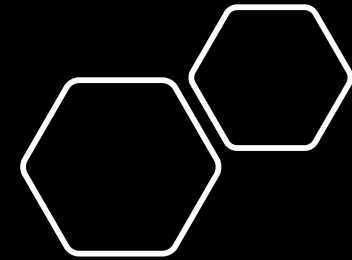

## Types of Electric Circuit

- **Open Circuit**-If due to disconnection of any part of an **electric circuit** if there is no flow of current the circuit is said to be open circuited.

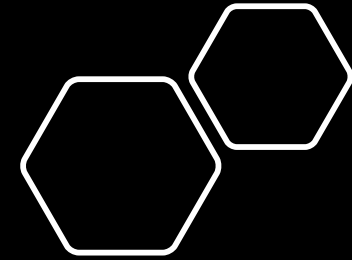
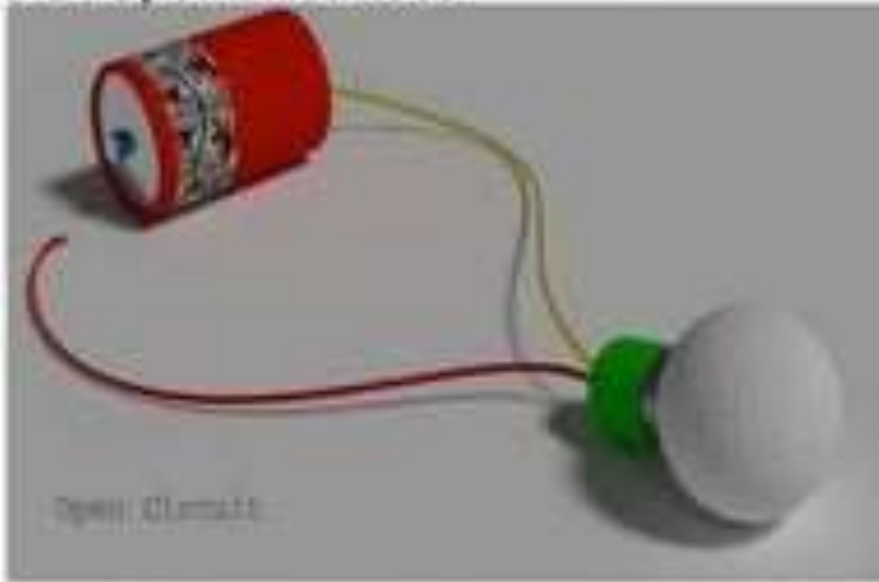

- **Closed Circuit**-If there is no discontinuity in the circuit and current can flow from one part to another part of the circuit then the circuit is said to be closed circuit.

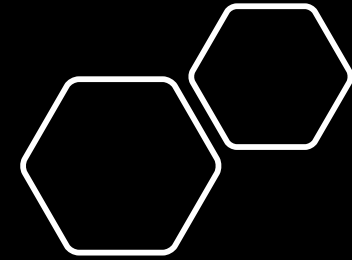
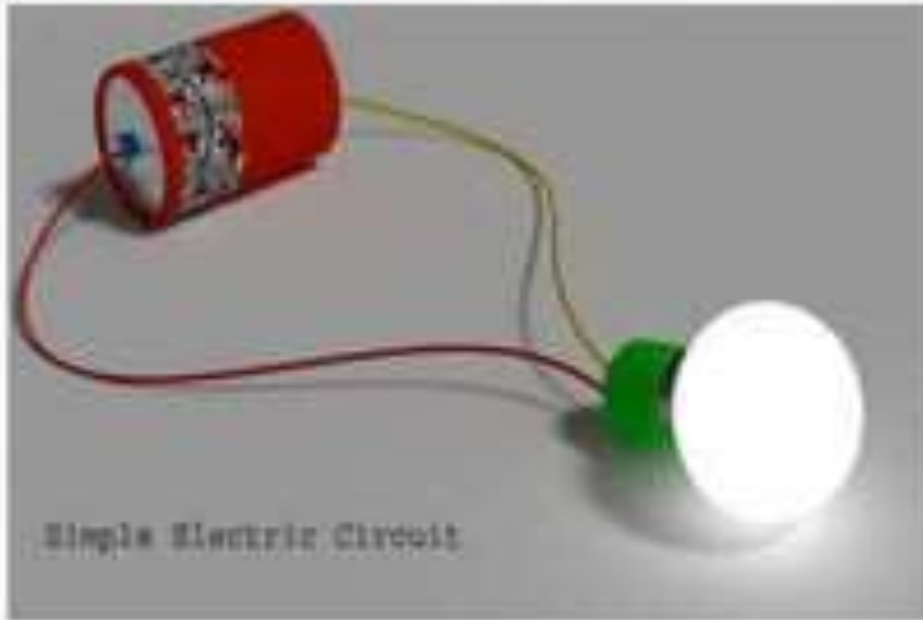

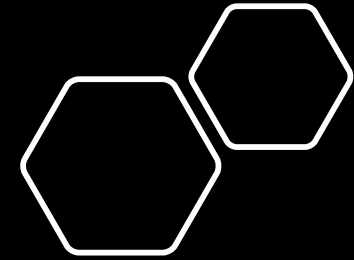

Electric circuits can further be categorized according to their structural features.

- Series Circuit
- Parallel Circuit
- Series Parallel Circuit.

## IDEAL VOLTAGE SOURCE

An **ideal voltage source** is a two-terminal device that maintains a fixed voltage drop across its terminals. It is often used as a mathematical abstraction that simplifies the analysis of real electric circuits

Ideal Voltage Source →



## IDEAL CURRENT SOURCE

A **current source** is an electronic circuit that delivers or absorbs an electric current which is independent of the voltage across it.

A current source is the dual of a voltage source.

Ideal current source →

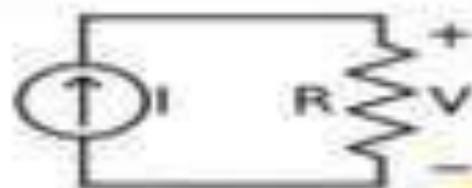

## DEPENDENT SOURCES

➤ In the theory of electrical networks, a dependent source is a voltage or a current source whose value depends on a voltage or current somewhere else in the network.

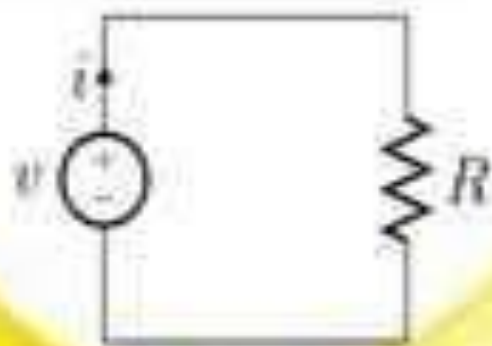

--> A simple electric circuit made up of a voltage source and a resistor.  
Here ,  $V=iR$  (Ohm's law)

- Some voltage (current) sources have their voltage (current) values varying with some other variables.
- They are called *dependent* voltage (current) sources or *controlled* voltage (current) sources.

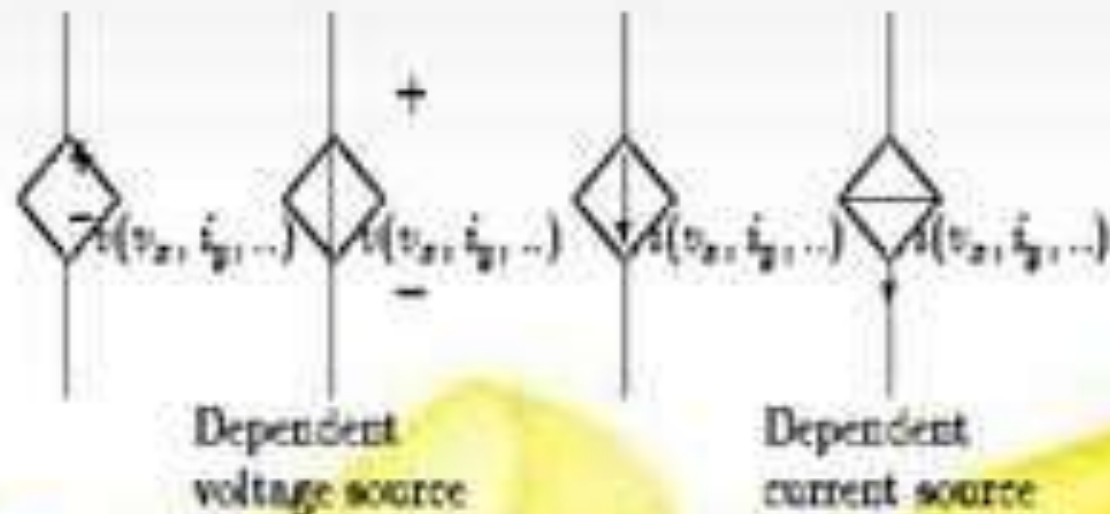

# CLASSIFICATION

Dependent sources can be classified as follows:

1. Voltage-controlled voltage source:

The source delivers the voltage as per the voltage of the dependent element.

$$V = \{f_a\}(\{v_x\})$$

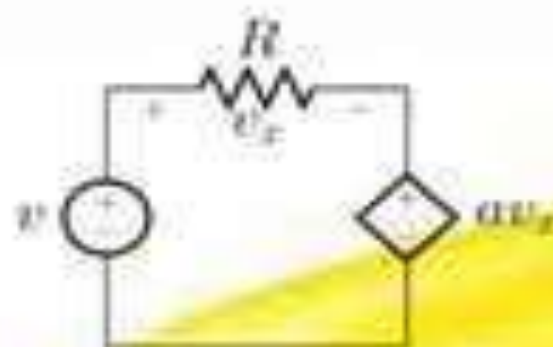

## 2. Voltage-controlled current source:

The source delivers the current as per the voltage of the dependent element.

$$I = \{f_{\{b\}}\}(\{v_{\{x\}}\})$$

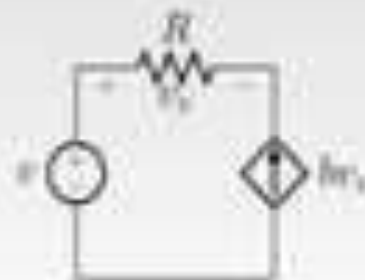

## 3. Current-controlled current source:

The source delivers the current as per the current of the dependent element.

$$I = \{f_{\{c\}}\}(\{i_{\{x\}}\})$$

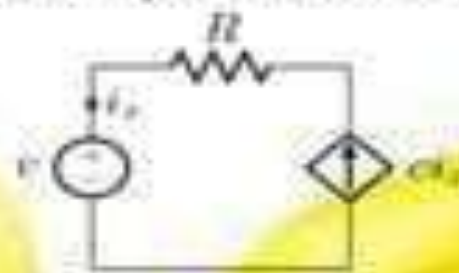

#### 4. Current-controlled voltage source:

The source delivers the voltage as per the current of the dependent element.

$$V = \{f_d\}(i_x)$$

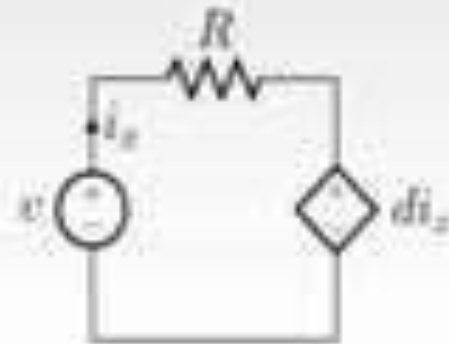

## INDEPENDENT SOURCES

An *independent voltage source* maintains a voltage (fixed or varying with time) which is not affected by any other quantity. Similarly an *independent current source* maintains a current (fixed or time-varying) which is unaffected by any other quantity.

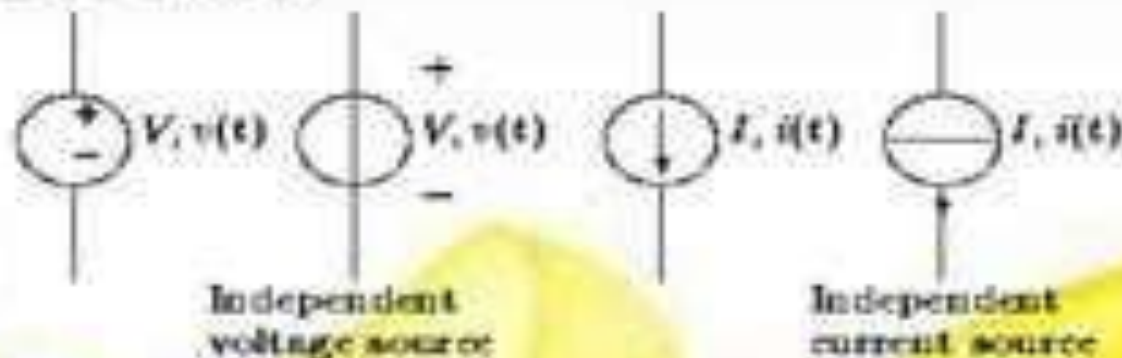

# SOURCE TRANSFORMATION

- It is process of in which the circuit can be simplify or modified which make our circuit more is to solve ,
- There are many ways to solve the circuit to make it simple
- The lis are given bellow

- If any circuit is having the voltage source in series it can be converted into current source with parallel with that resistance. This process can be reciprocated

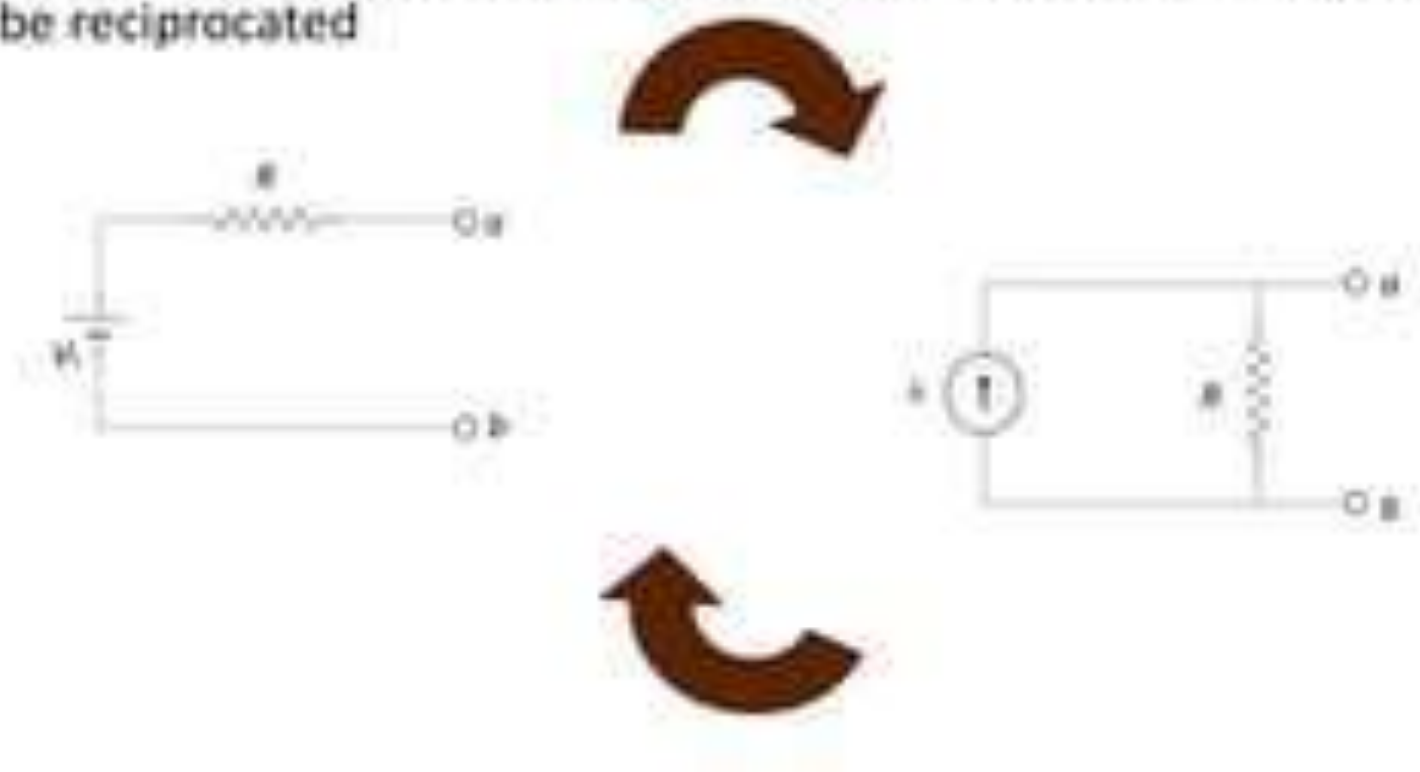

## Example

- Use source transformation to find  $v_o$  in the circuit.

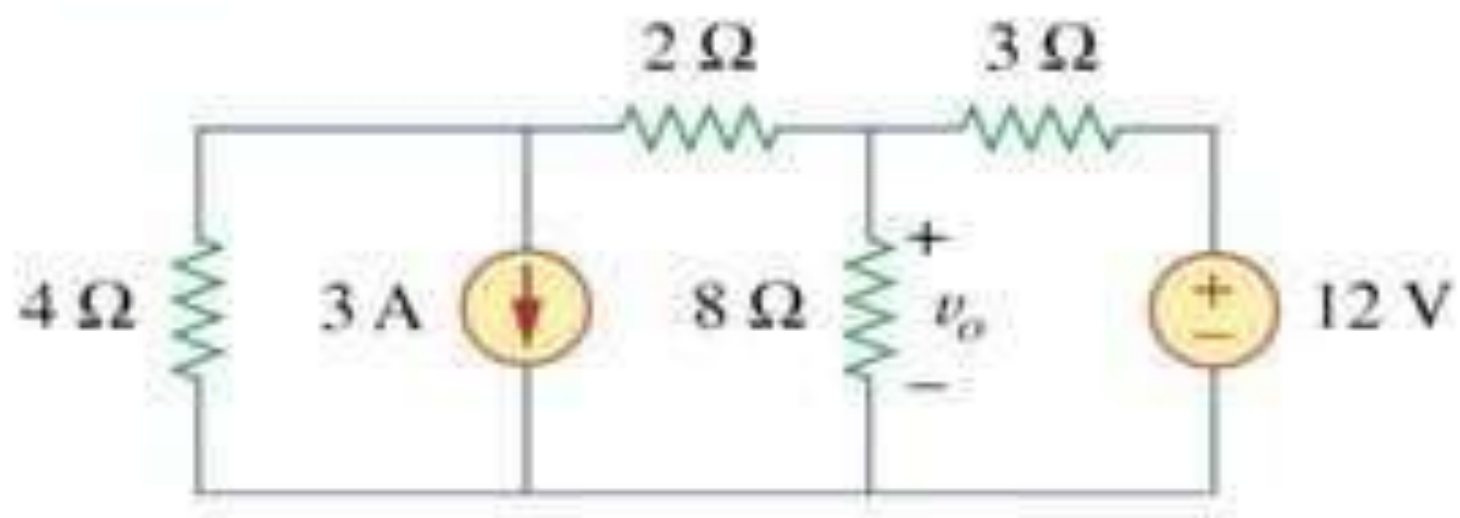

## Example

we use current division to get

$$i = \frac{2}{2+8}(2) = 0.4\text{A}$$

and

$$v_o = 8i = 8(0.4) = 3.2\text{V}$$

## Star-Delta Transformation

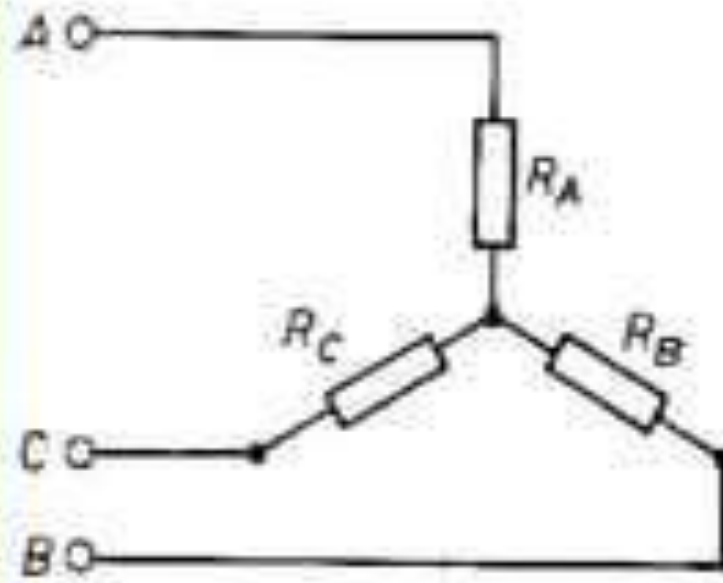

(a) Star (Y) section

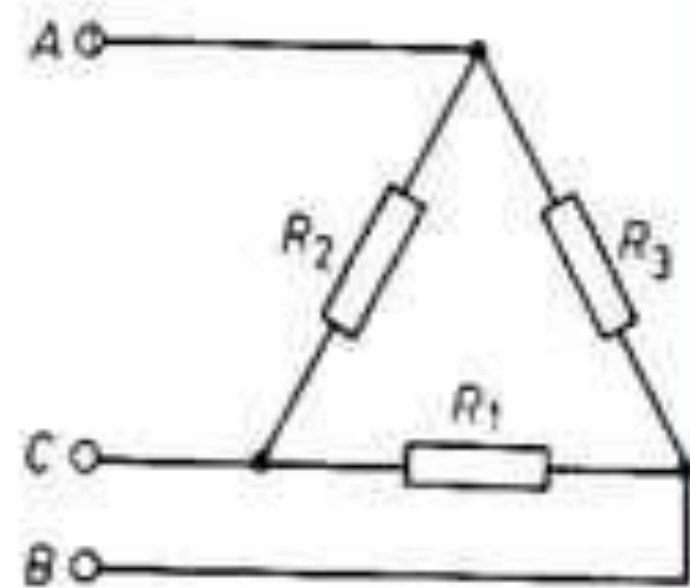

(b) Delta or mesh ( $\Delta$ ) section

## Equivalence

- **Equivalence can be found on the basis that the resistance between any pair of terminals in the two circuits have to be the same, when the third terminal is left open.**

### DELTA to STAR

Now subtracting 2 from 1 and adding the result to 3, we will get the following values for  $R_1$ ,  $R_2$  and  $R_3$ .

$$R_A = \frac{R_2 R_3}{R_1 + R_2 + R_3}$$

$$R_B = \frac{R_3 R_1}{R_1 + R_2 + R_3}$$

$$R_C = \frac{R_1 R_2}{R_1 + R_2 + R_3}$$

How to remember?

Resistance of each arm of star is given by the product of the resistance of the two delta sides that meet at its ends divided by the sum of the three delta resistance

### STAR to DELTA

Multiplying 1 and 2, 2 and 3, 3 and 1 and adding them together and simplifying, we will have the following result.

$$R_1 = \frac{R_A R_B + R_B R_C + R_C R_A}{R_A}$$

$$R_2 = \frac{R_A R_B + R_B R_C + R_C R_A}{R_B}$$

$$R_3 = \frac{R_A R_B + R_B R_C + R_C R_A}{R_C}$$

How to remember: The equivalent delta resistance between any two points is given by the product of resistance taken two at a time divided by the opposite resistance in the star configuration.

## Problem

- A delta-section of resistors is given in figure. Convert this into an equivalent star-section.

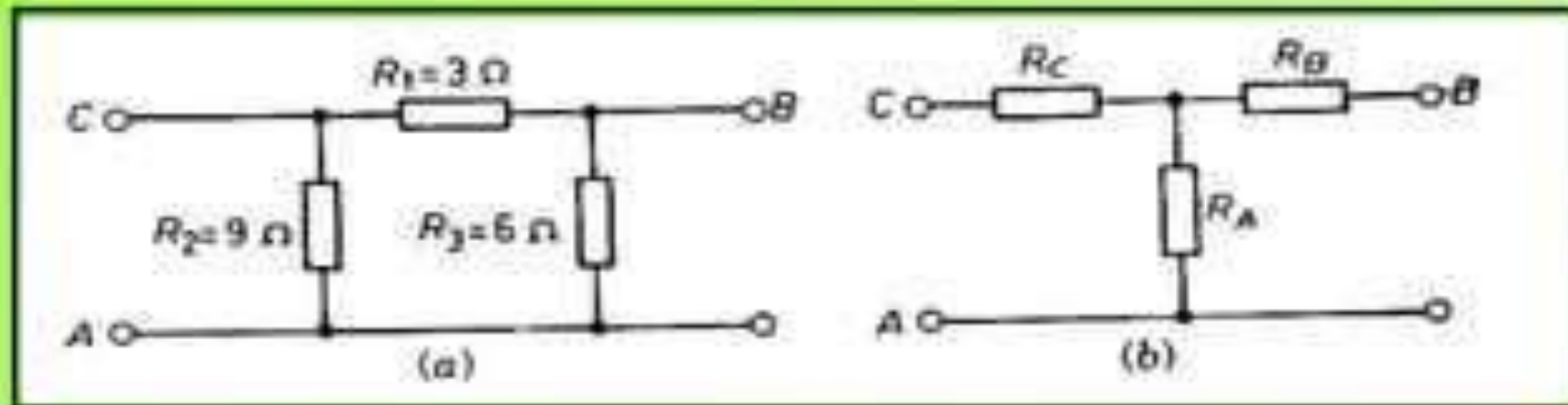

**Ans. :**  $R_A = 3 \Omega$ ;  $R_B = 1.0 \Omega$ ;  $R_C = 1.5 \Omega$ .

## Problem

The figure shows a network. The number on each branch represents the value of resistance in ohms. Find the resistance between the points  $E$  and  $F$ .

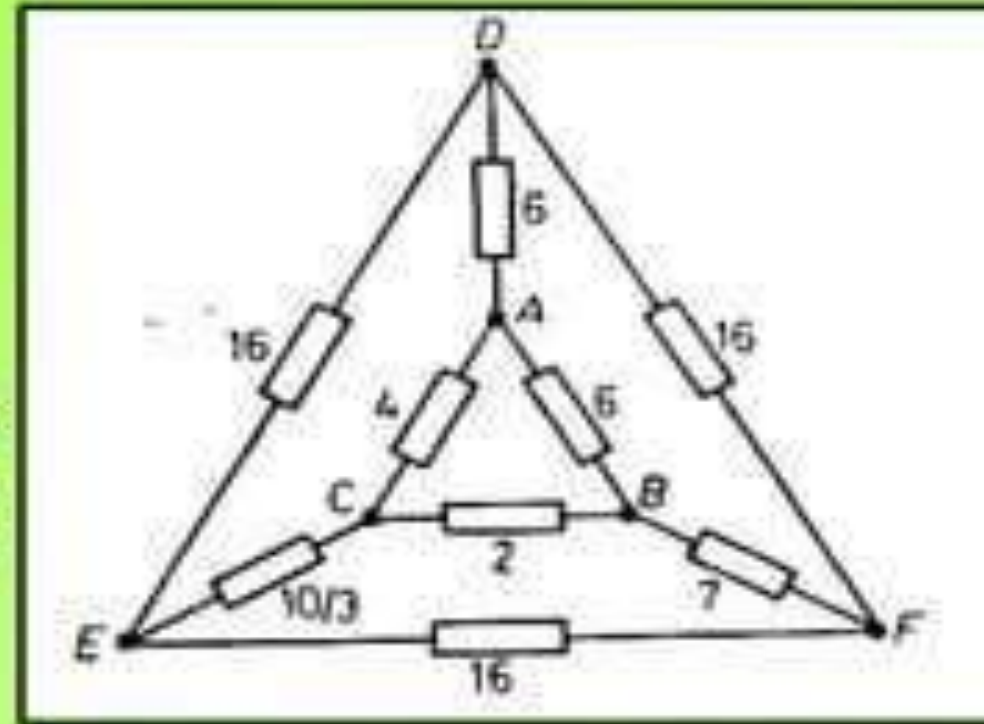

## Solution

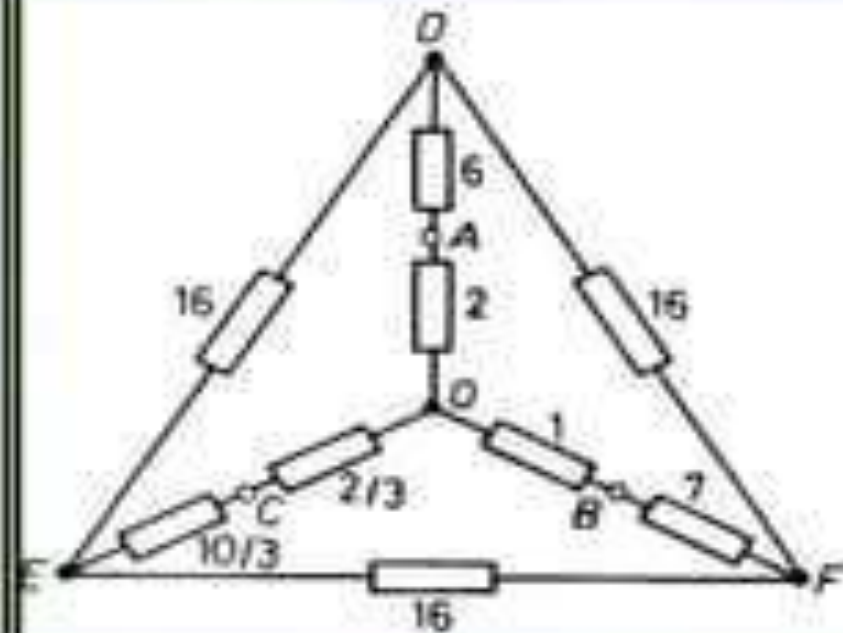
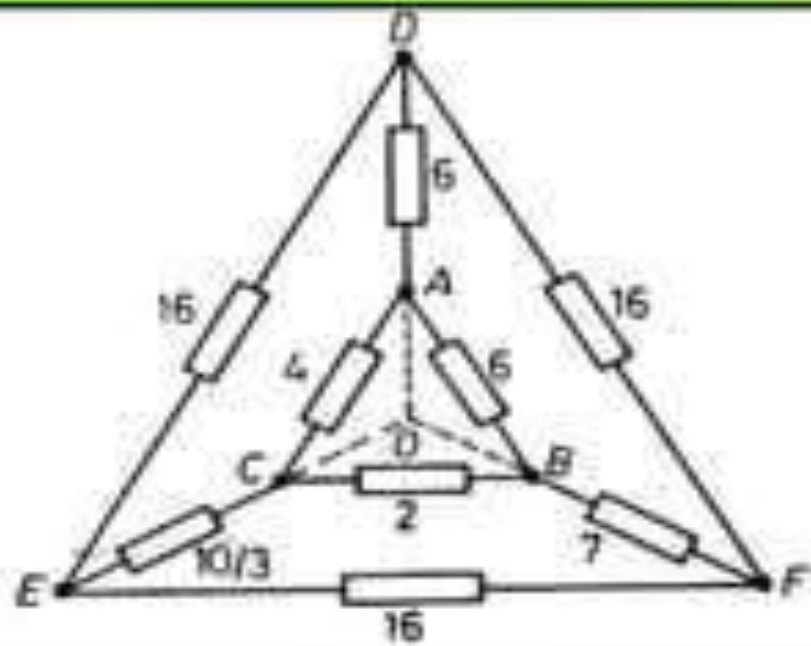

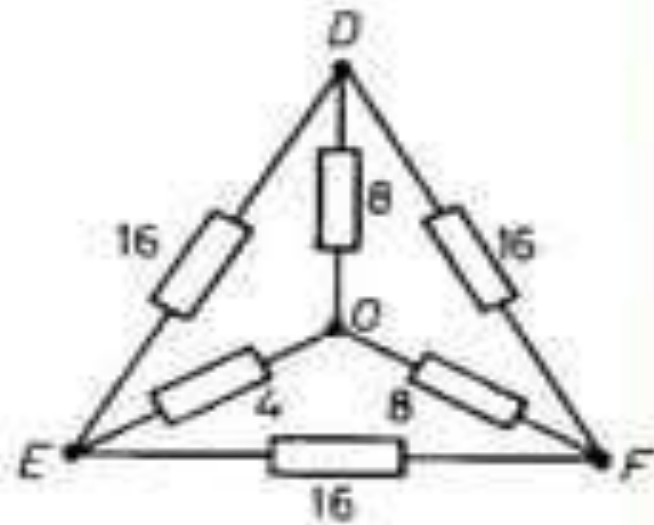

Ans. : 5.6 Ω

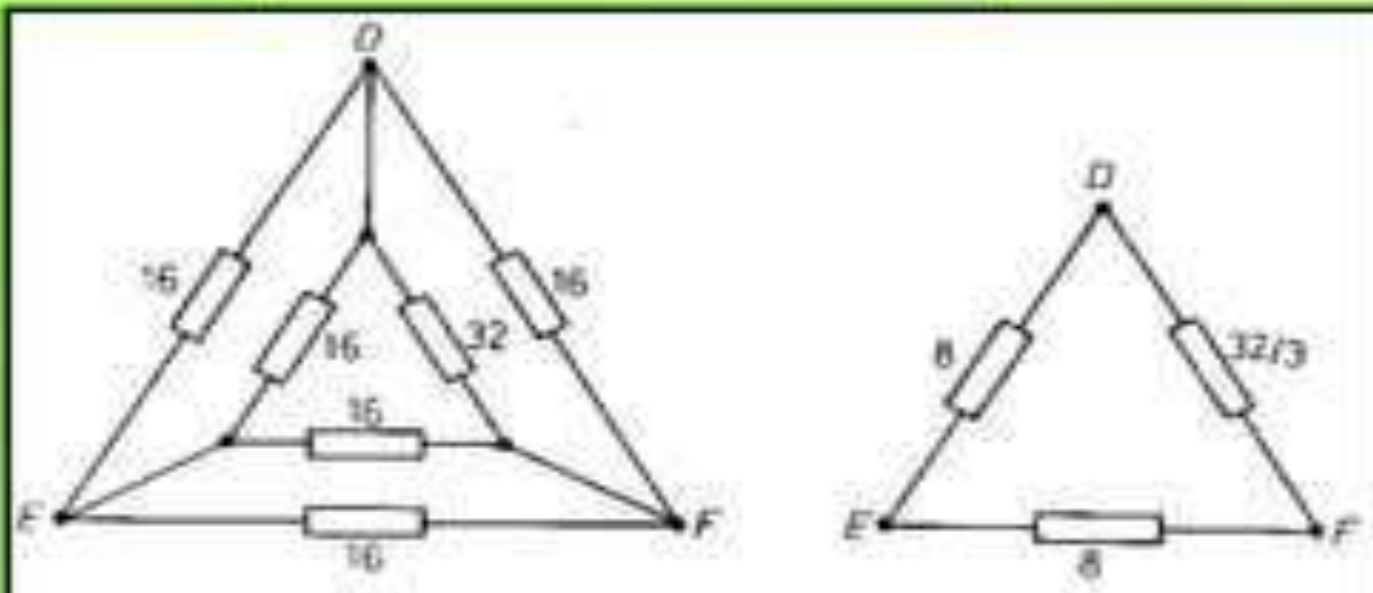

## **Difference between Magnetic and Electric Circuit**

The Difference between the Magnetic and Electric Circuit are explained considering various factors like the basic definition, relation between Flux and Current, Reluctance and Resistance, EMF and MMF, different analogies of both the circuits. Like its density and intensity, laws applicable in the circuit, Magnetic and Electric lines, etc.

**BASIS****MAGNETIC CIRCUIT****ELECTRIC CIRCUIT**

Definition

The closed path for magnetic flux is called magnetic circuit.

The closed path for electric current is called electric circuit.

Relation Between Flux and Current

$$\text{Flux} = \text{mmf} / \text{reluctance}$$
$$\text{Current} = \text{emf} / \text{resistance}$$

Units

Flux  $\phi$  is measured in weber (wb)

Current  $I$  is measured in amperes

MMF  
EMF

and Magnetomotive force is the driving force and is measured in Ampere turns (AT)  
$$\text{Mmf} = \int H \cdot dl$$

Electromotive force is the driving force and measured in volts (V)  
$$\text{Emf} = \int E \cdot dl$$

Reluctance and Resistance	Reluctance opposes the flow of magnetic flux $S = l/a\mu$ and measured in (AT/wb)	Resistance opposes the flow of current $R = \rho \cdot l/a$ and measured in ( $\Omega$ )
Relation between	Permeance = 1/reluctance	Conduction = 1/ resistance
Permeance and Conduction		
Analogy	Permeability	Conductivity
Analogy	Reluctivity	Resistivity
Density	Flux density $B = \phi/a$ (wb/m <sup>2</sup> )	Current density $J = I/a$ (A/m <sup>2</sup> )
Intensity	Magnetic intensity $H = NI/l$	Electric density $E = V/d$
Drops	Mmf drop = $\phi S$	Voltage drop = IR

<p>Flux and Electrons</p>	<p>In magnetic circuit molecular poles are aligned. The flux does not flow, but sets up in the magnetic circuit.</p>	<p>In electric circuit electric current flows in the form of electrons.</p>
<p>Examples</p>	<p>For magnetic flux, there is no perfect insulator. It can set up even in the non magnetic materials like air, rubber, glass etc.</p>	<p>For electric circuit there are a large number of perfect insulators like glass, air, rubber, PVC and synthetic resin which do not allow it to flow through them.</p>
<p>Variation of Reluctance and Resistance</p>	<p>The reluctance (S) of a magnetic circuit is not constant rather it varies with the value of B.</p>	<p>The resistance (R) of an electric circuit is almost constant as its value depends upon the value of <math>\rho</math>. The value of <math>\rho</math> and R can change slightly if the change in temperature takes place</p>

# Magnetic Circuit

The closed path followed by magnetic lines of forces or magnetic flux is called magnetic circuit. A magnetic circuit is made up of magnetic materials having high permeability such as iron, soft steel, etc. Magnetic circuits are used in various devices like electric motor, transformers, relays, generators galvanometer, etc.

# Electric Circuit

The rearrangement by which various electrical sources like AC source or DC source, resistances, capacitance and another electrical parameter are connected is called electric circuit or electrical network.

# Coupled circuit

An electric circuit is said to be a **coupled circuit**, when there exists a mutual inductance between the coils (or inductors) present in that circuit. In the absence of resistor, coil becomes inductor. Sometimes, the terms coil and inductor are interchangeably used.

# Dot Convention

Dot convention is a technique, which gives the details about voltage polarity at the dotted terminal. This information is useful, while writing KVL equations.

- If the current enters at the dotted terminal of one coil (or inductor), then it induces a voltage at another coil (or inductor), which is having **positive polarity** at the dotted terminal.
- If the current leaves from the dotted terminal of one coil (or inductor), then it induces a voltage at another coil (or inductor), which is having **negative polarity** at the dotted terminal.

## Classification of Coupling

**Coupling** is classified into the following two categories.

- **Electrical Coupling**
- **Magnetic Coupling**

# Electrical Coupling

- Electrical coupling occurs, when there exists a **physical connection** between two coils (or inductors). This coupling can be of either aiding type or opposing type. It is based on whether the current enters at the dotted terminal or leaves from the dotted terminal.

# Coupling of Aiding type

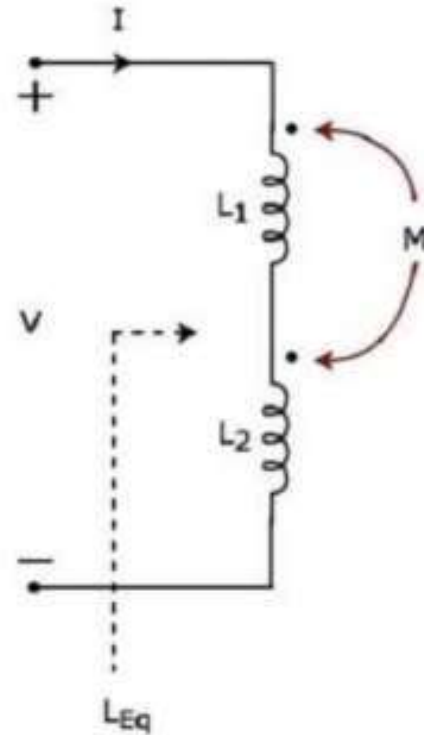

- Since the two inductors are connected in series, the **same current  $I$**  flow through both inductors having self-inductances  $L_1$  and  $L_2$ .
- In this case, the current,  $I$  enter at the dotted terminal of each inductor. Hence, the induced voltage in each inductor will be having **positive polarity** at the dotted terminal due to the current flowing in another coil.
- Therefore, the **equivalent inductance** of series combination of inductors shown in the above figure is
$$L_{eff} = L_1 + L_2 + 2M$$

# Coupling of Opposing type

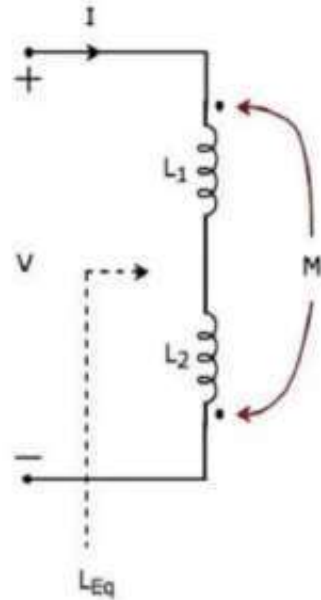

In the circuit, the current  $I$  enters at the dotted terminal of the inductor having an inductance of  $L_1$ . Hence, it induces a voltage in the other inductor having an inductance of  $L_2$ .

So, **positive polarity** of the induced voltage is present at the dotted terminal of this inductor.

In the above circuit, the current  $I$  leaves from the dotted terminal of the inductor having an inductance of  $L_2$ . Hence, it induces a voltage in the other inductor having an inductance of  $L_1$ . So, **negative polarity** of the induced voltage is present at the dotted terminal of this inductor.

Therefore, the **equivalent inductance** of series combination of inductors shown in the above figure is  $L_{eff} = L_1 + L_2 - 2M$

In this case, the equivalent inductance has been decreased by  $2M$ . Hence, the above electrical circuit is an example of **electrical coupling** which is of **opposing** type.

# Magnetic Coupling

- Magnetic coupling occurs, when there is **no physical connection** between two coils (or inductors). This coupling can be of either aiding type or opposing type. It is based on whether the current enters at the dotted terminal or leaves from the dotted terminal.

# Coupling of Aiding type

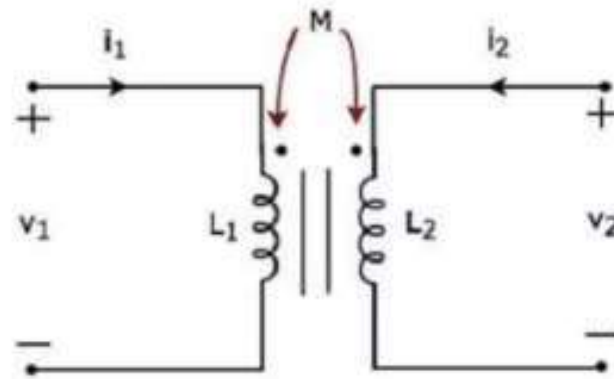

The currents flowing through primary and secondary coils are  $i_1$  and  $i_2$  respectively.

In this case, these currents **enter** at the dotted terminal of respective coil. Hence, the induced voltage in each coil will be having positive polarity at the dotted terminal due to the current flowing in another coil.

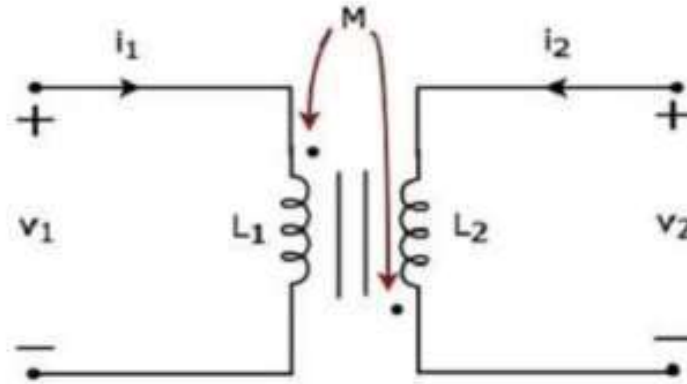

# Coupling of Opposing Type



The currents flowing through primary and secondary coils are  $i_1$  and  $i_2$  respectively. In this case, the current,  $i_1$  enters at the dotted terminal of primary coil. Hence, it induces a voltage in secondary coil. So, **positive polarity** of the induced voltage is present at the dotted terminal of this secondary coil.

In the above circuit, the current,  $i_2$  leaves from the dotted terminal of secondary coil. Hence, it induces a voltage in primary coil. So, **negative polarity** of the induced voltage is present at the dotted terminal of this primary coil.

# UNIT - 2



## Objectives

- To introduce the mesh – current method.
- To formulate the mesh-current equations.
- To solve electric circuits using the mesh-current method.

## Mesh Analysis (Loop Analysis)

- Mesh Analysis is developed by applying KVL around meshes in the circuit.
- Loop (mesh) analysis results in a system of linear equations which must be solved for unknown currents.
- Reduces the number of required equations to the number of meshes
- Can be done systematically with little thinking
- As usual, be careful writing mesh equations – follow sign convention.

# Definitions

**Mesh:** Loop that does not enclose other loops

**Essential Branch:** Path between 2 essential nodes (without crossing other essential nodes).

**How many mesh-currents?**

# of essential nodes

$N_e = 4$

# of essential branches

$B_e = 6$

No. of Mesh-currents

$M = B_e - (N_e - 1)$

• Enough equations to get unknowns

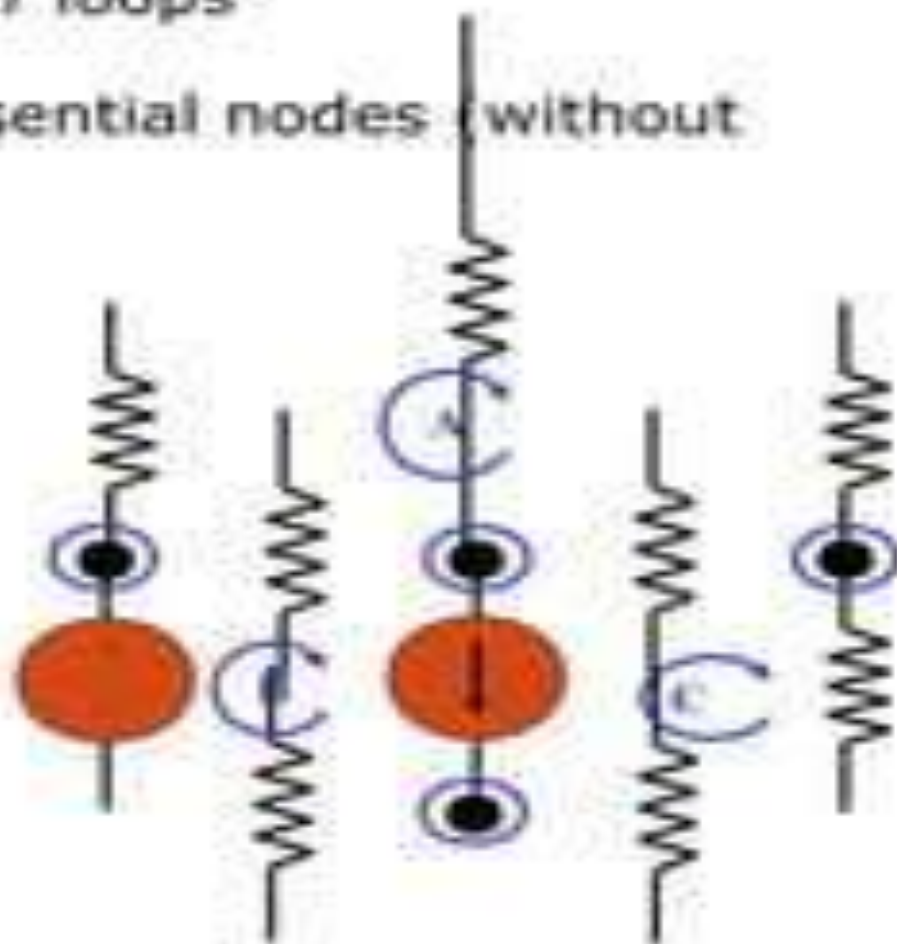



## Steps of Mesh Analysis

1. Identify the number of basic meshes.
2. Assign a current to each mesh.
3. Apply KVL around each loop to get an equation in terms of the loop currents.
4. Solve the resulting system of linear equations.

Identifying the Meshes

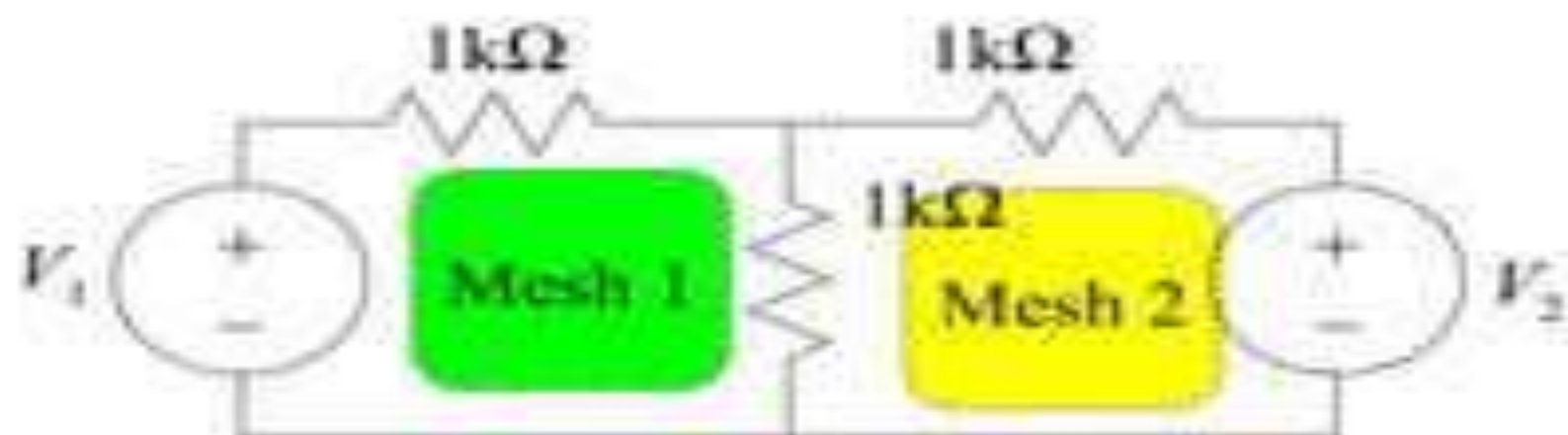

Assigning Mesh Currents

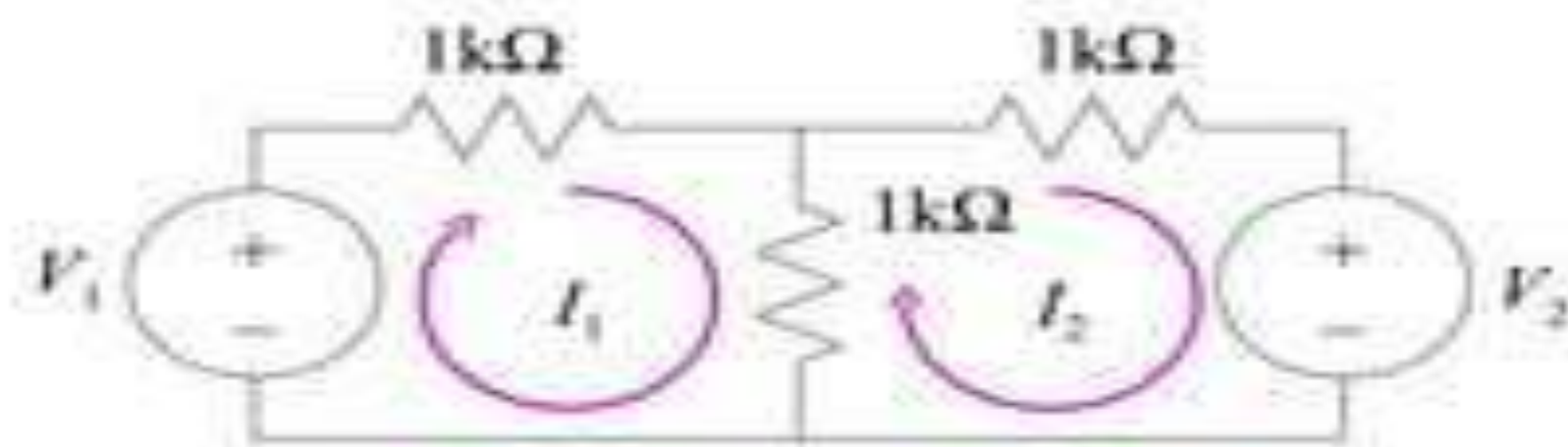



### Voltages from Mesh Currents



$$V_R = I_1 R$$

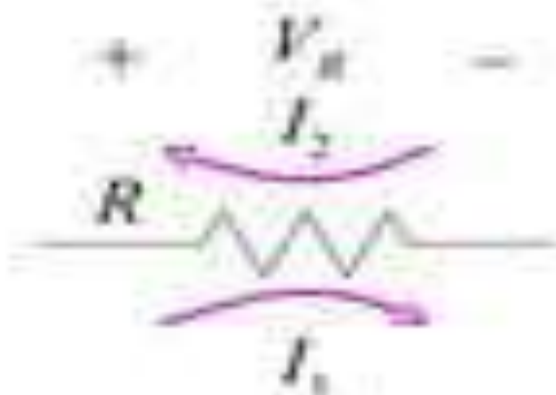

$$V_R = (I_1 - I_2) R$$

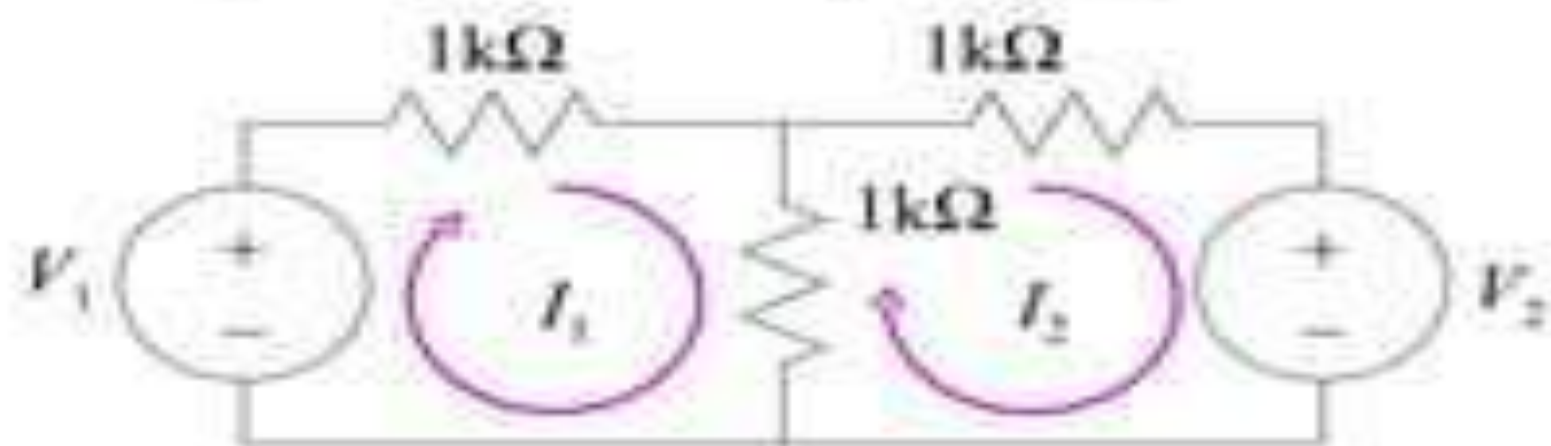

Mesh-Current Equations

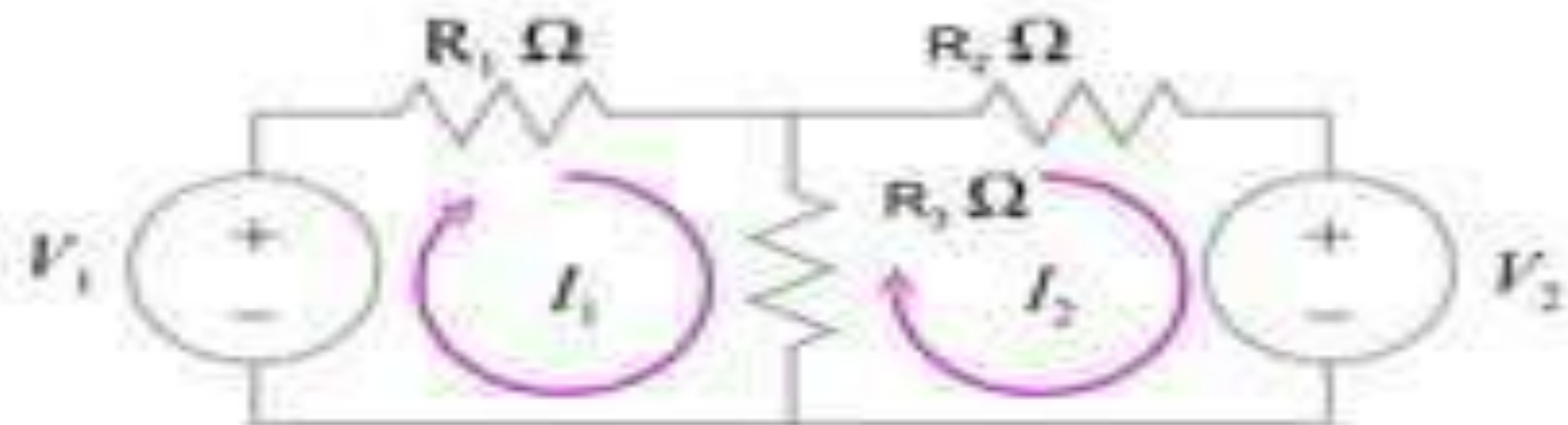

$$-V_1 + I_1 R_1 + (I_1 - I_2) R_3 = 0$$

$$I_2 R_2 + V_2 + (I_2 - I_1) R_3 = 0$$



### Mesh Current Method

1. Assign mesh currents
2. Write mesh equations

$$i_1(20+6+4) + (i_1-i_2)(4+6) = 0$$
$$i_2(2+4+4) + (i_2-i_1)(4+6) - 70 = 0$$

3. Solve mesh equations

$$40i_1 - 10i_2 = 0$$
$$-10i_1 + 20i_2 = 70$$

---

$$40i_1 - 10i_2 = 0$$
$$70i_2 = 280$$

Solution:  $i_1 = 1A$ ;  $i_2 = 4A$

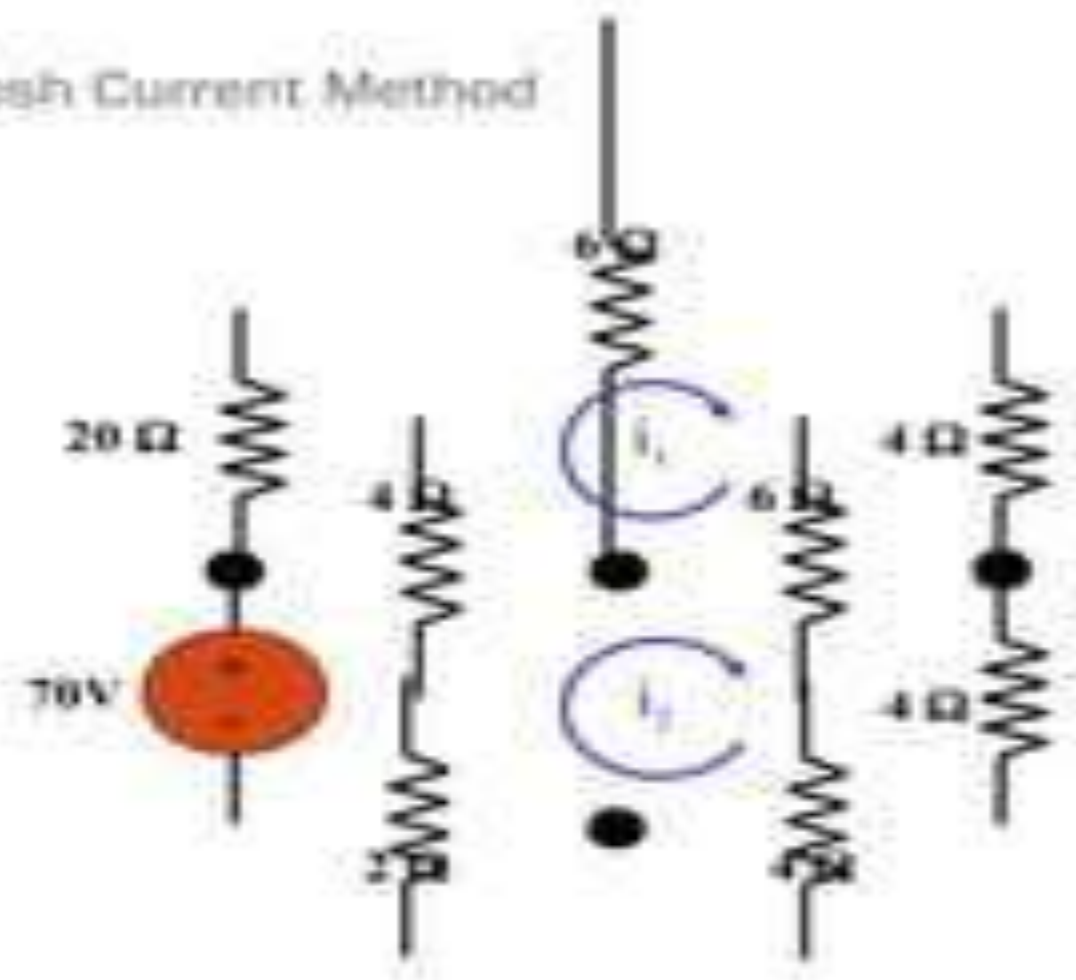

Case 1: When a current source exists only in one mesh

Loop 1

$$-10 + 4i_1 + 6(i_1 - i_2) = 0$$

Loop 2

$$i_2 = -5A$$

No need to write a loop equation

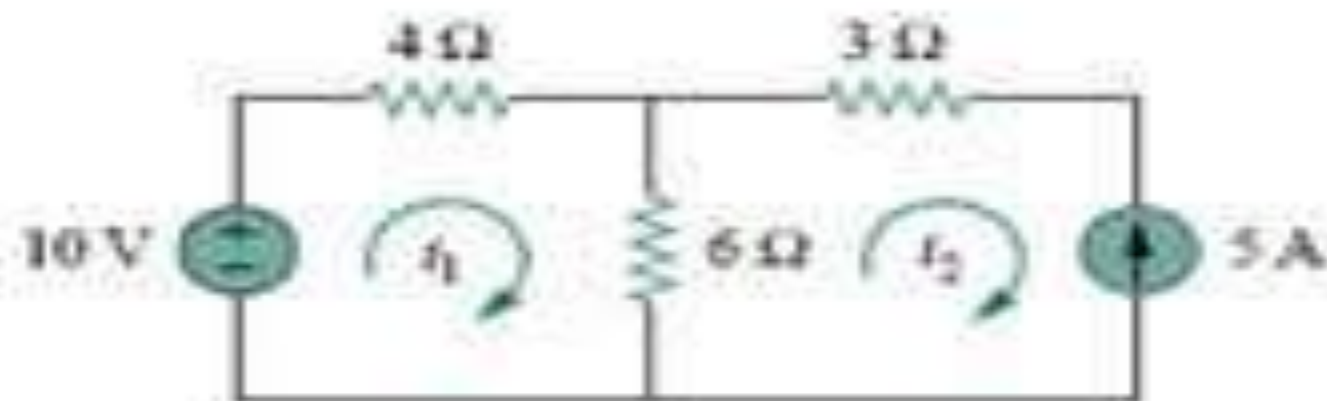

## Case II: Super Mesh

When a current source exists between two meshes

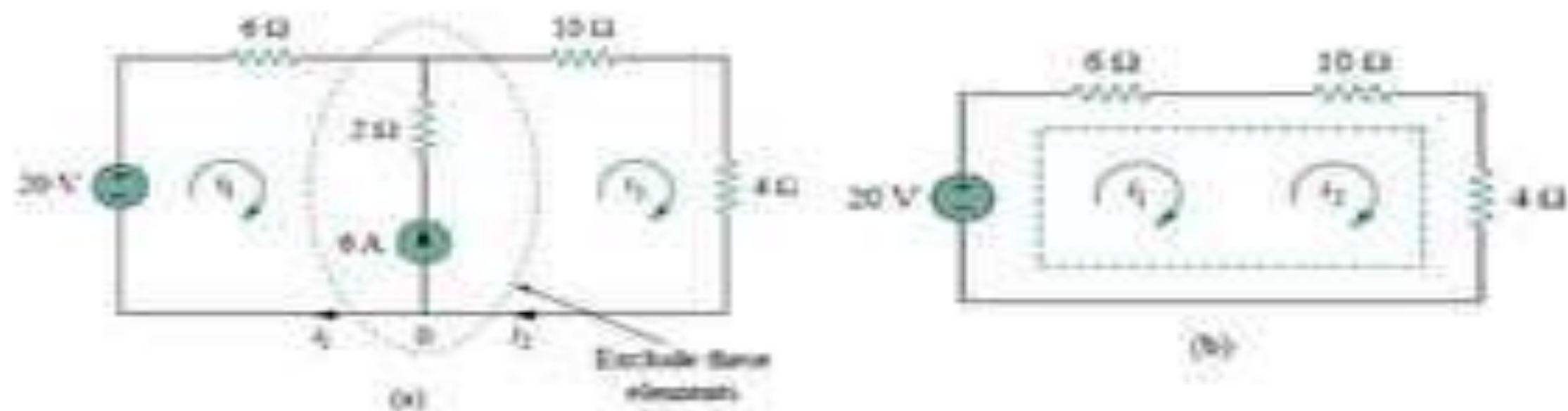

$$-20 + 6i_1 + 10i_2 + 4i_2 = 0$$

$$i_2 = i_1 + 6$$

$$i_1 = -3.2 \text{ A}$$

$$i_2 = 2.8 \text{ A}$$



Case III: Mesh with Dependent Sources

$$-75 + 5i_1 + 20(i_1 - i_2) = 0$$

$$10i_2 + 20(i_2 - i_1) + 4i_2 = 0$$

$$i_3 = i_1 - i_2$$

$$-75 + 5i_3 + 20(i_1 - i_2) = 0$$

$$10(i_1 - i_2) + 20(i_2 - i_1) + 4i_2 = 0$$

$$i_2 = -5A$$

$$i_1 = 7A$$

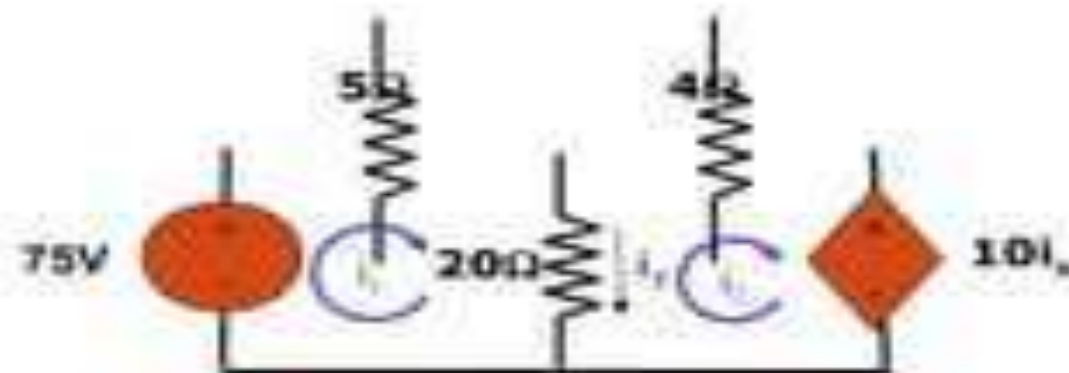

## Example

Use the mesh-current method to find  $i_o$ .

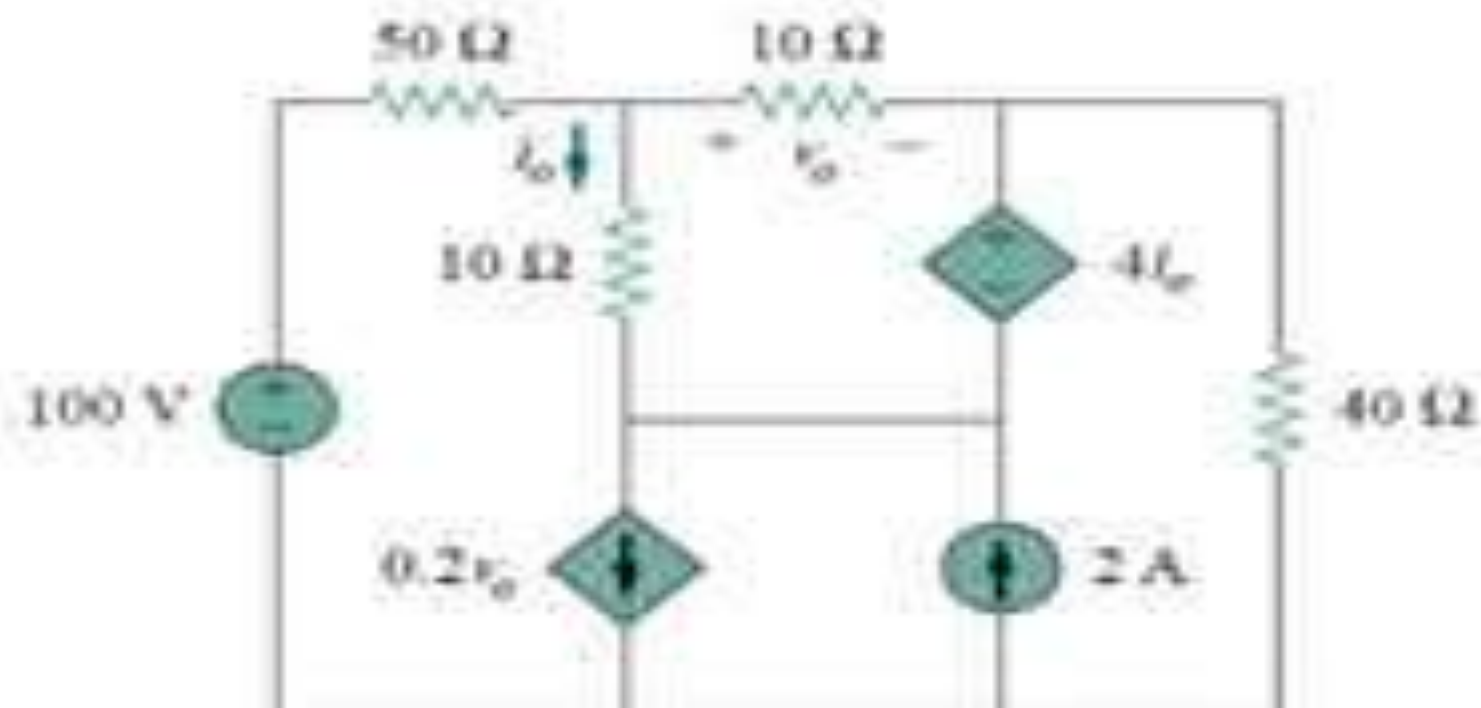

Ans.  $i_o = 1$  A

# Solution

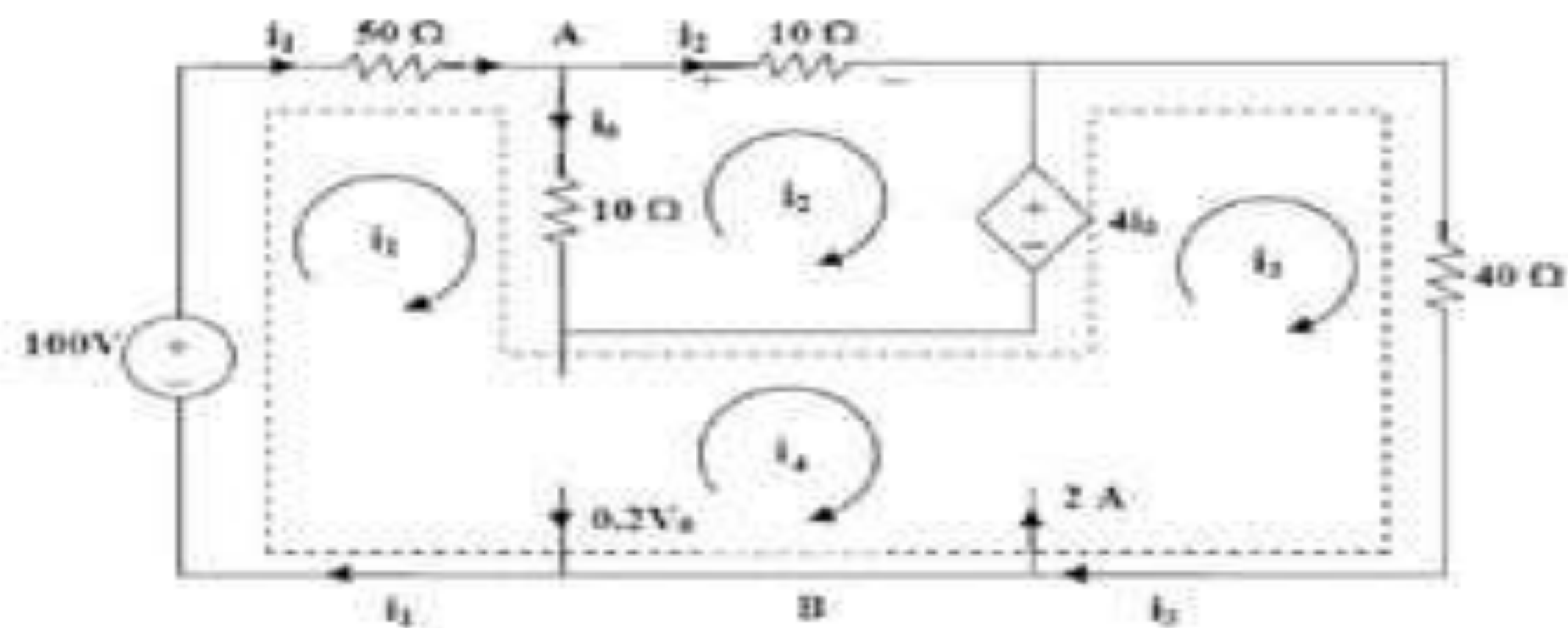

## Solution

For mesh 2,  $20i_2 - 10i_1 + 4i_0 = 0$  (1)

But at node A,  $i_0 = i_1 - i_2$  so that (1) becomes  $i_1 = (10/6)i_2$  (2)

For the supermesh,  $-100 + 50i_1 + 10(i_1 - i_2) - 4i_0 + 40i_3 = 0$

or  $50 = 28i_1 - 3i_2 + 20i_3$  (3)

$$i_3 - 4 = 2 \qquad e_4 - i_3 = 0.2v_0 \quad (4)$$

But,  $v_0 = 10i_2$  so that (4) becomes  $i_3 = 2 + (2/3)i_2$  (5)

Solving (1) to (5),  $i_2 = 0.11764$ .

$$v_0 = 10i_2 = \underline{1.1764 \text{ volts}}, \quad i_0 = i_1 - i_2 = (5/3)i_2 = \underline{196.07 \text{ mA}}$$

# Nodal Analysis

- The node-voltage method is based on following idea. Instead of solving for circuit variables,
- $i$  and  $v$  of each element, we solve for a different set of parameters, node voltages in this case,
- which automatically satisfy KVLs. As such, we do not need to write KVLs and only need to solve KCLs.

# Nodal Analysis

- Nodal analysis is more commonly used than mesh or loop analysis for analysing networks.
- It can be used to determine the unknown node voltages of both planar and non-planar circuits.
- Nodal equations are usually formed by applying Kirchoff's Current Law to the nodes with unknown voltages, whereas equations based on Kirchoff's Voltage

# Nodal Analysis

- In order to apply nodal analysis to a circuit, the first step is to select ***a reference node or datum node and then assign a voltage at each of the other nodes with respect to the reference node.***

# Procedure in Nodal Analysis

- Select a reference node and treat it to be at zero or ground potential.
- Label the nodes with unknown voltages.
- At each of these nodes, mark currents in the elements as flowing away from
  - the node.
- Form KCL equations and solve the set of simultaneous equations for the
  - unknown voltages.

# Nodes

- **Node** refers to any point on a circuit where two or more circuit elements meet. For two nodes to be different, their voltages must be different. Without any further knowledge, it is easy to establish how to find a node by using Ohm's Law:  $V=IR$ . When looking at circuit schematics, ideal wires have a resistance of zero. Since it can be assumed that there is no change in the potential across any part of the wire, all of the wire in between any components in a circuit is considered part of the same node.

## Simple sample problem

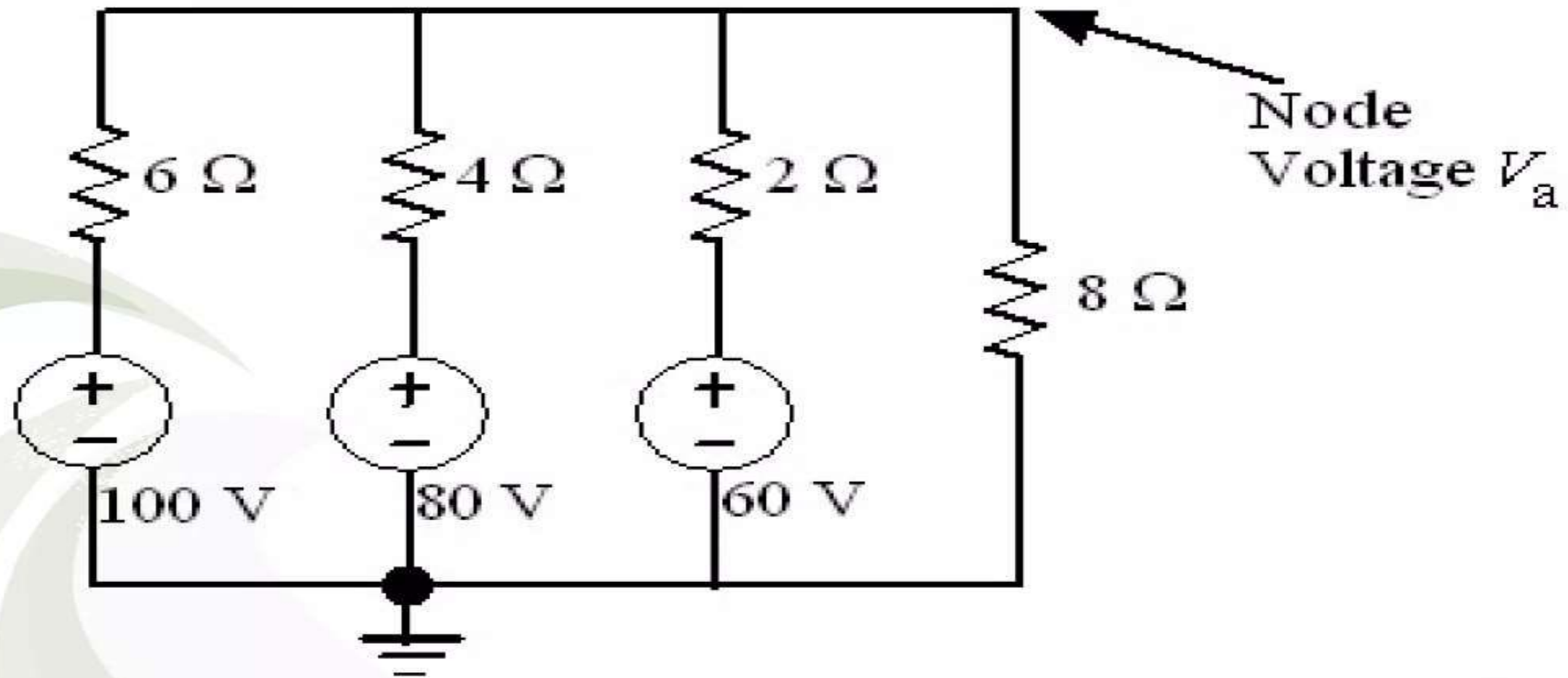
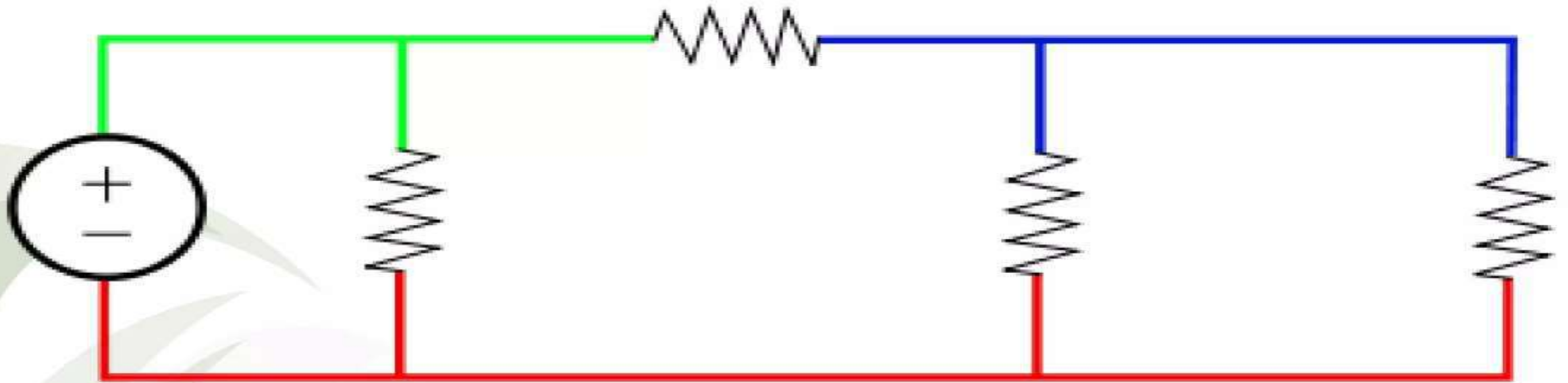

Fig. 8: Worked Example: 3

Answer

$$V_a = 64$$

# Nodes with same voltage



- In this circuit diagram the voltage in the **green node** is the **same** throughout, likewise, the voltages in the **blue node** and the **red node** are the same throughout.

# Enter vs. Leaving

- $I_{\text{enter}} = I_{\text{leaving}}$
- Node equation:  $I_1 + I_2 = I_3$ ,
- As you can see  $I_1$  and  $I_2$  are entering the node and  $I_3$  is exiting the node. If we move  $I_3$  to the left side of the Node equation, then the node equation becomes,
- Node equation:  $I_1 + I_2 + (-I_3) = 0$

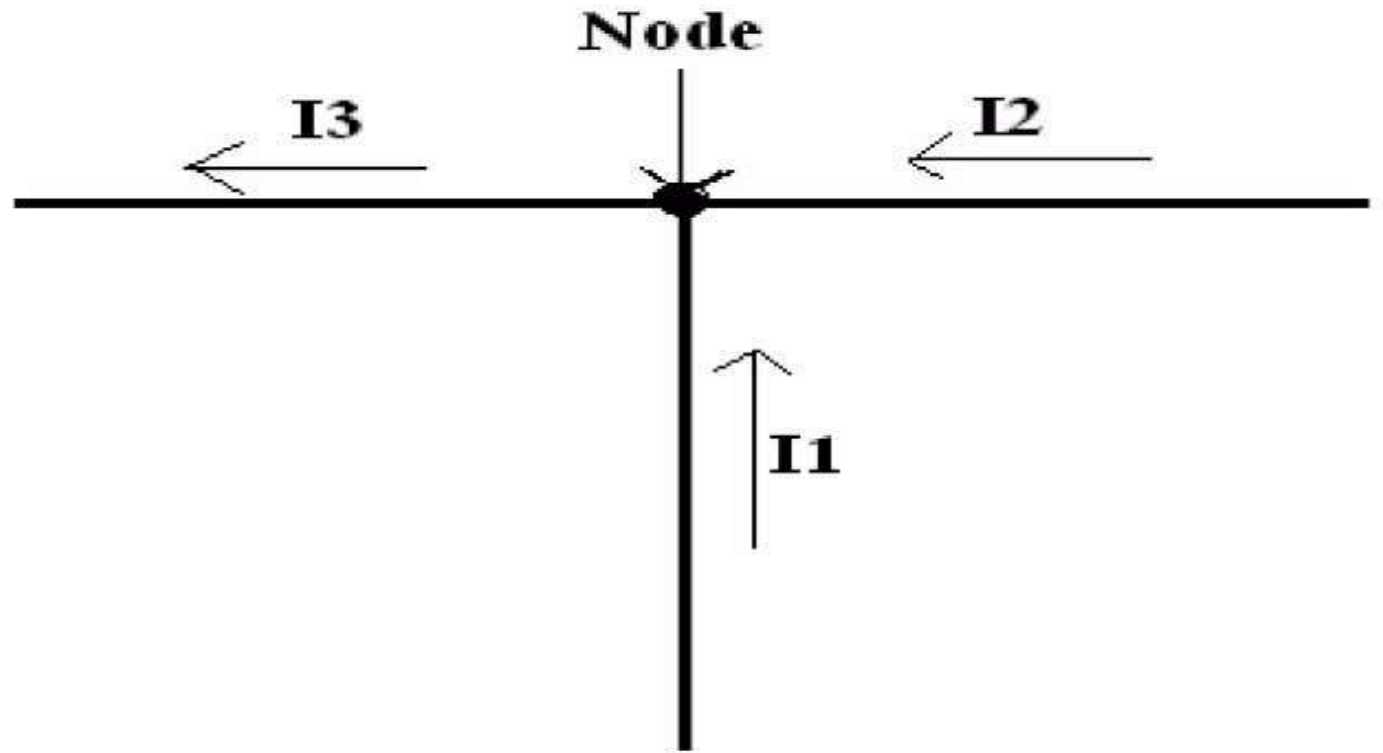

# UNIT - 3

# Single Phase AC

- ❖ *Characteristics of Sinusoidal*
- ❖ *Phasors*
- ❖ *Phasor Relationships for R, L and C*
- ❖ *Impedance*
- ❖ *Parallel and Series Resonance*
- ❖ *Examples for Sinusoidal Circuits Analysis*

# Sinusoidal Steady State Analysis

- Any steady state voltage or current in a linear circuit with a sinusoidal source is a sinusoid
  - All steady state voltages and currents have the same frequency as the source
- In order to find a steady state voltage or current, all we need to know is its magnitude and its phase relative to the source (we already know its frequency)
- We do not have to find this differential equation from the circuit, nor do we have to solve it
- Instead, we use the concepts of phasors and complex impedances
- Phasors and complex impedances convert problems involving differential equations into circuit analysis problems

## Characteristics of Sinusoids

### Outline:

1. Time Period:  $T$
2. Frequency:  $f$  (Hertz)
3. Angular Frequency:  $\omega$  (rad/sec)
4. Phase angle:  $\Phi$
5. Amplitude:  $V_m I_m$

# Characteristics of Sinusoids :

$$v(t) = V_m \sin \omega t$$

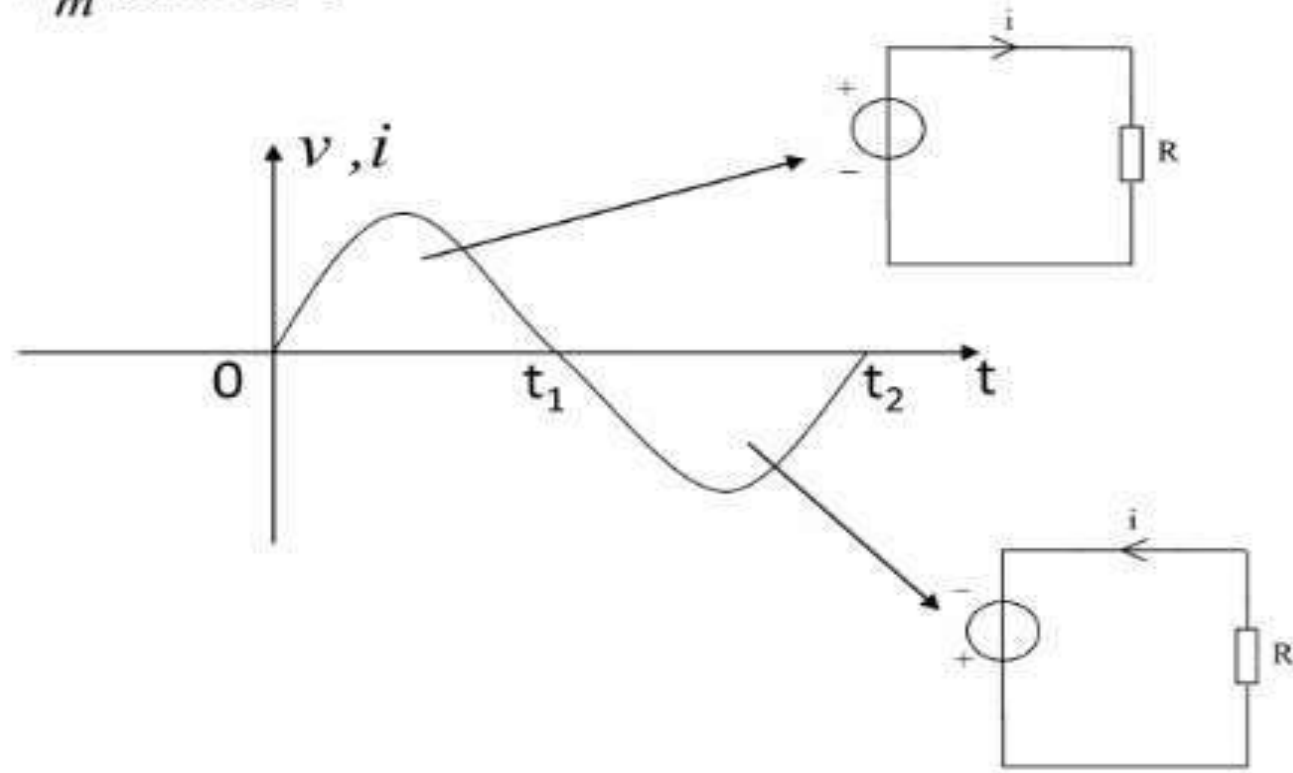

Both the polarity and magnitude of voltage are changing.

## Characteristics of Sinusoids :

**Time Period:  $T$**  — Time necessary to go through one cycle. (s)

**Frequency:  $f$**  — Cycles per second. (Hz)

$$f = 1/T$$

**Radian frequency(Angular frequency):  $\omega = 2\pi f = 2\pi/T$**  (rad/s)

**Amplitude:  $V_m$   $I_m$**

$$i = I_m \sin \omega t, \quad v = V_m \sin \omega t$$

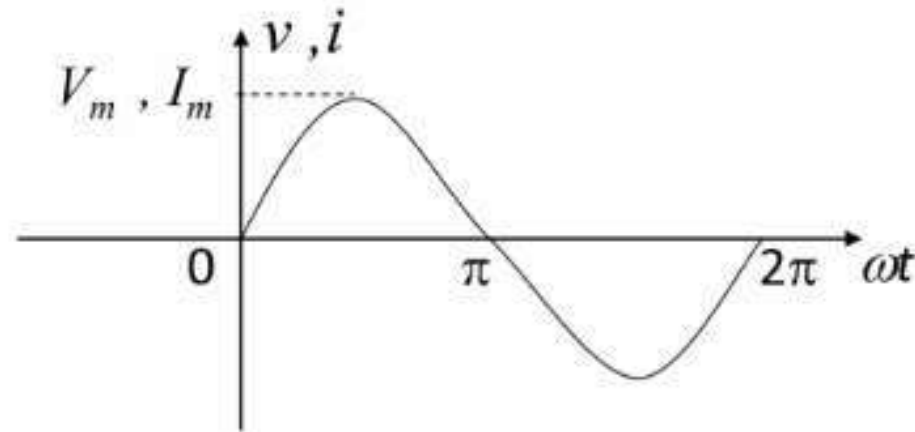

## Characteristics of Sinusoids :

**Effective Root Mean Square (RMS) Value of a Periodic Waveform** — is equal to the value of the direct current which is flowing through an R-ohm resistor. It delivers the same average power to the resistor as the periodic current does.

$$\frac{1}{T} \int_0^T i^2 R dt = I^2 R$$

————→ Effective Value of a Periodic Waveform  $I_{eff} = \sqrt{\frac{1}{T} \int_0^T i^2 dt}$

$$I_{eff} = \sqrt{\frac{1}{T} \int_0^T I_m^2 \sin^2 \omega t dt} = \sqrt{\frac{I_m^2}{T} \int_0^T \frac{1 - \cos 2\omega t}{2} dt} = \sqrt{\frac{1}{T} I_m^2 \cdot \frac{T}{2}} = \frac{I_m}{\sqrt{2}}$$

$$V_{eff} = \sqrt{\frac{1}{T} \int_0^T v^2 dt} = \frac{V_m}{\sqrt{2}}$$

## Characteristics of Sinusoids :

Phase (angle)

$$i = I_m \sin(\omega t + \varphi)$$

Phase angle

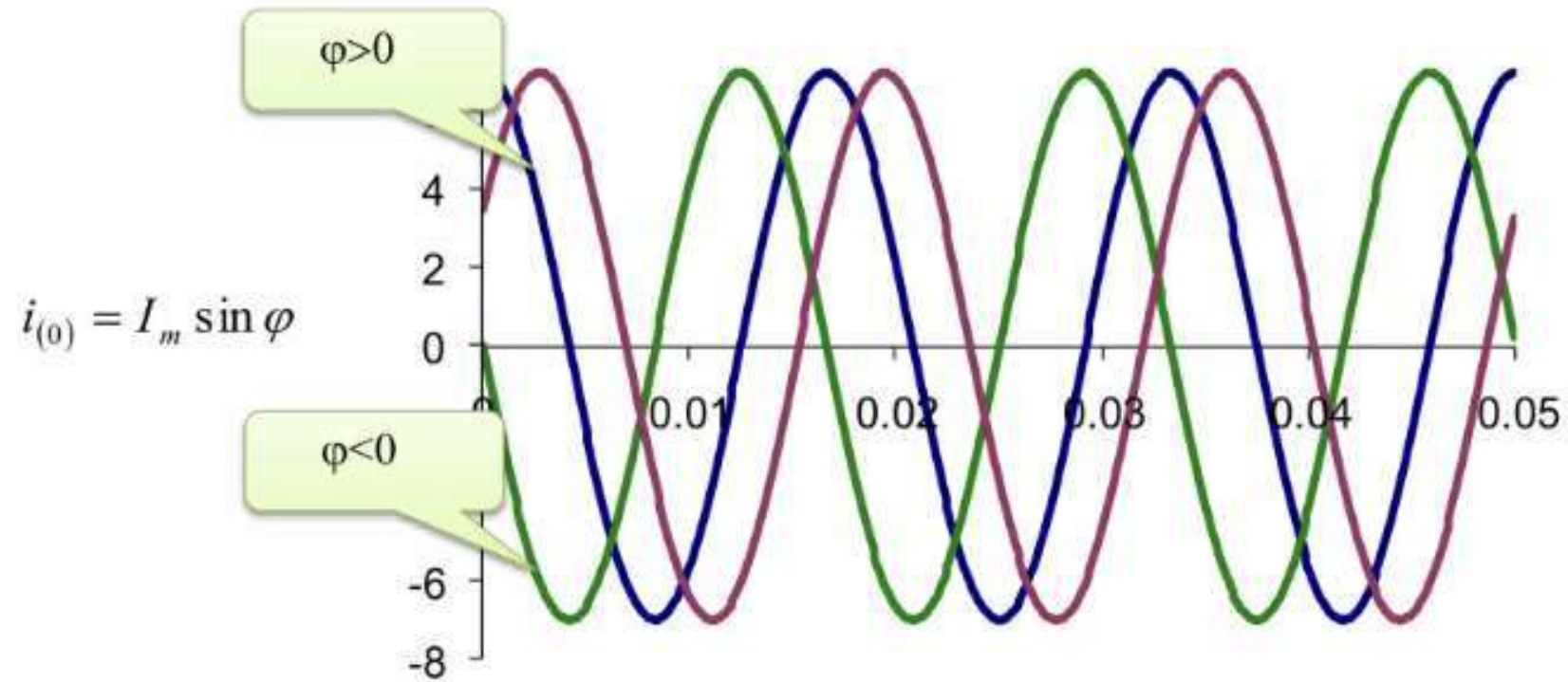

## Characteristics of Sinusoids :

### *Phase difference*

$$v = V_m \sin(\omega t + \varphi_1) \quad i = I_m \sin(\omega t + \varphi_2)$$

$$\Delta\varphi = \varphi_v - \varphi_i = \omega t + \varphi_1 - (\omega t + \varphi_2) = \varphi_1 - \varphi_2$$

$\Delta\varphi = \varphi_1 - \varphi_2 > 0$  —  $v(t)$  leads  $i(t)$  by  $(\varphi_1 - \varphi_2)$ , or  $i(t)$  lags  $v(t)$  by  $(\varphi_1 - \varphi_2)$

$\Delta\varphi = \varphi_1 - \varphi_2 < 0$  —  $v(t)$  lags  $i(t)$  by  $(\varphi_2 - \varphi_1)$ , or  $i(t)$  leads  $v(t)$  by  $(\varphi_2 - \varphi_1)$

$\Delta\varphi = \varphi_1 - \varphi_2 = 0$   
In phase

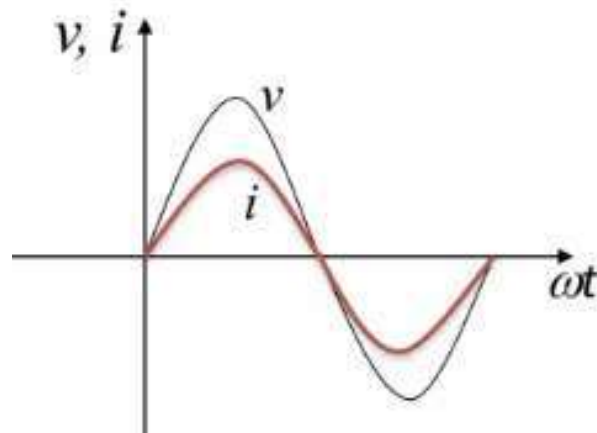

$\Delta\varphi = \varphi_1 - \varphi_2 = \pm \frac{\pi}{2}$

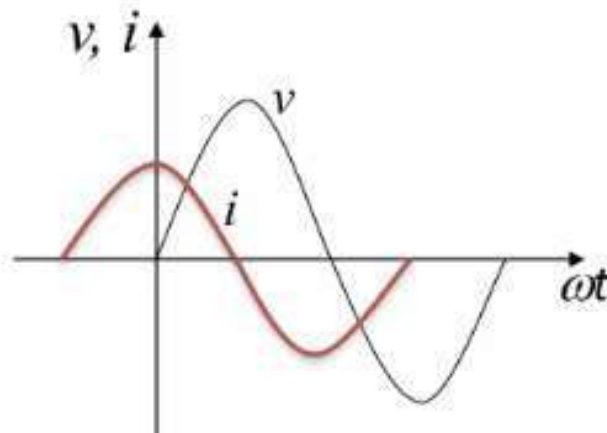

$\Delta\varphi = \varphi_1 - \varphi_2 = \pi$   
Out of phase

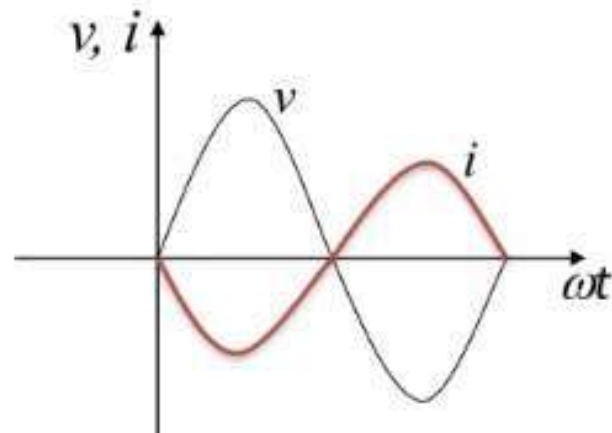

## Characteristics of Sinusoids :

### Review

---

The sinusoidal waves whose phases are compared must:

1. Be written as sine waves or cosine waves.
  2. With positive amplitudes.
  3. Have the same frequency.
- 

$360^\circ$  ——— does not change anything.

$90^\circ$  ——— change between sin & cos.

$180^\circ$  ——— change between + & -

$$*\sin \theta = \cos \left( \theta + \frac{2}{3} \pi \right) = \cos \left( \theta - \frac{\pi}{2} \right)$$

$$*\cos \theta = \sin \left( \theta + \frac{\pi}{2} \right)$$

## Characteristics of Sinusoids :

### Phase difference

$$v_1 = 220\sqrt{2} \sin(314t - 30^\circ) \quad v_2 = 220\sqrt{2} \cos(314t + 30^\circ)$$

Find  $\Delta\varphi = ?$

$$\begin{aligned} v_2 &= 220\sqrt{2} \cos(314t + 30^\circ) = 220\sqrt{2} \sin(314t + 30^\circ + 90^\circ) \\ &= 220\sqrt{2} \sin(314t + 120^\circ) \end{aligned}$$

$$\Delta\varphi = \varphi_1 - \varphi_2 = -30^\circ - 120^\circ = -150^\circ$$

If  $v_2 = -220\sqrt{2} \cos(314t + 30^\circ)$

$$\begin{aligned} v_2 &= -220\sqrt{2} \cos(314t + 30^\circ) = 220\sqrt{2} \cos(314t + 30^\circ + 180^\circ) \\ &= 220\sqrt{2} \cos[360^\circ - (314t + 210^\circ)] \\ &= 220\sqrt{2} \sin(314t - 150^\circ + 90^\circ) \\ &= 220\sqrt{2} \sin(314t - 60^\circ) \end{aligned}$$

$$\Delta\varphi = \varphi_1 - \varphi_2 = -30^\circ + 60^\circ = 30^\circ$$

## Characteristics of Sinusoids :

### *Phase difference*

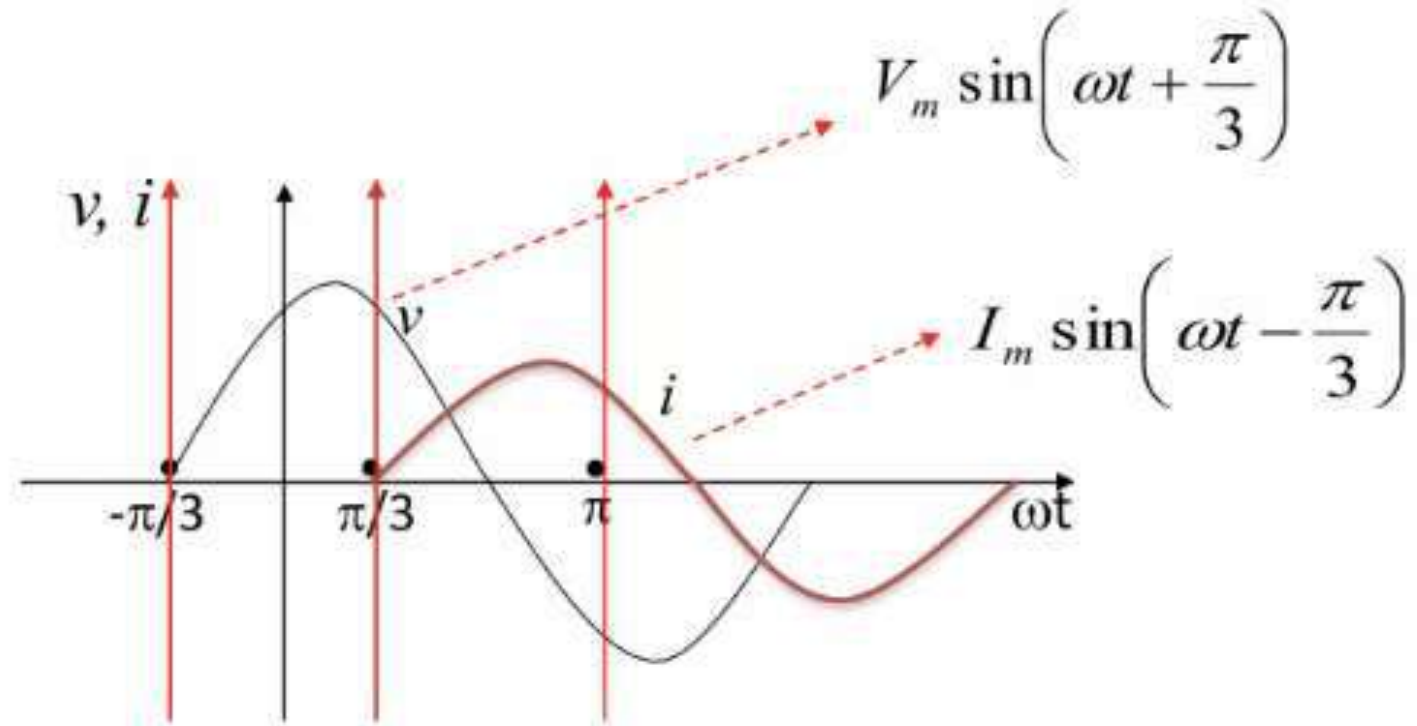

# Phasors

A phasor is a Complex Number which represents magnitude and phase of a sinusoid

## Outline:

1. Complex Numbers
2. Rotating Vector
3. Phasors

A sinusoidal voltage/current at a given frequency, is characterized by only two parameters : amplitude and phase

# Phasors

e.g. voltage response

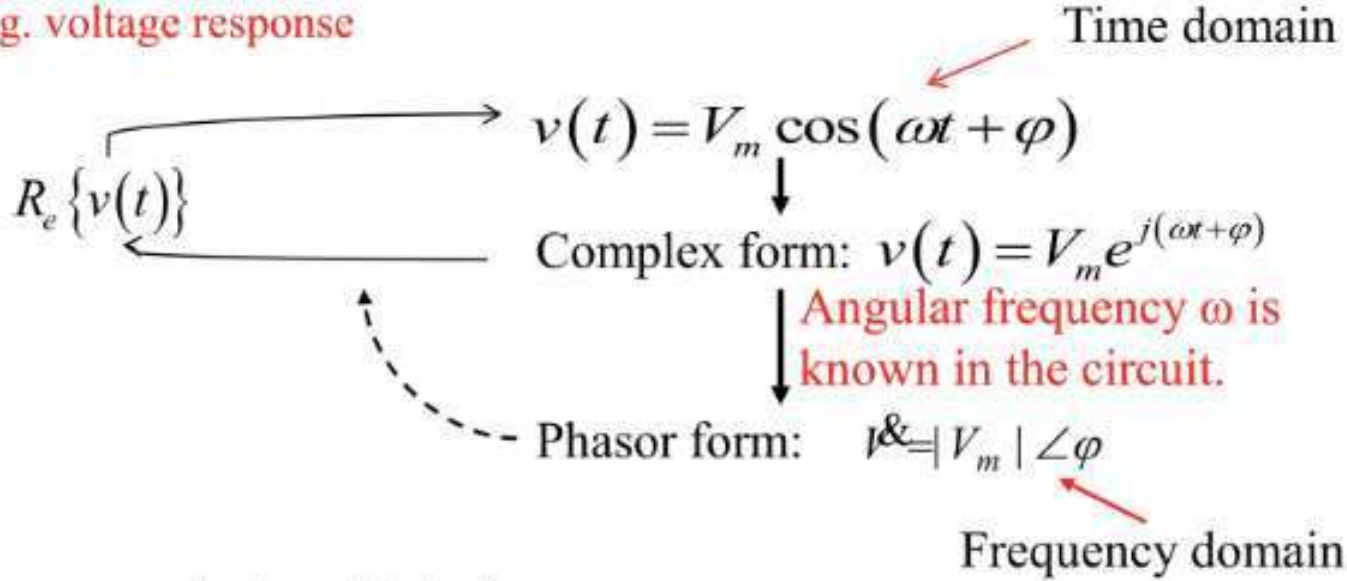

A sinusoidal  $v/i$

$$v(t) = V_m \cos(\omega t + \phi)$$

Complex transform

Phasor transform

$$\mathbf{V} = |V_m| \angle \phi$$

By knowing angular frequency  $\omega$  rads/s.

## Phasors

### Rotating Vector

$$i(t) = I_m \sin(\omega t + \varphi)$$

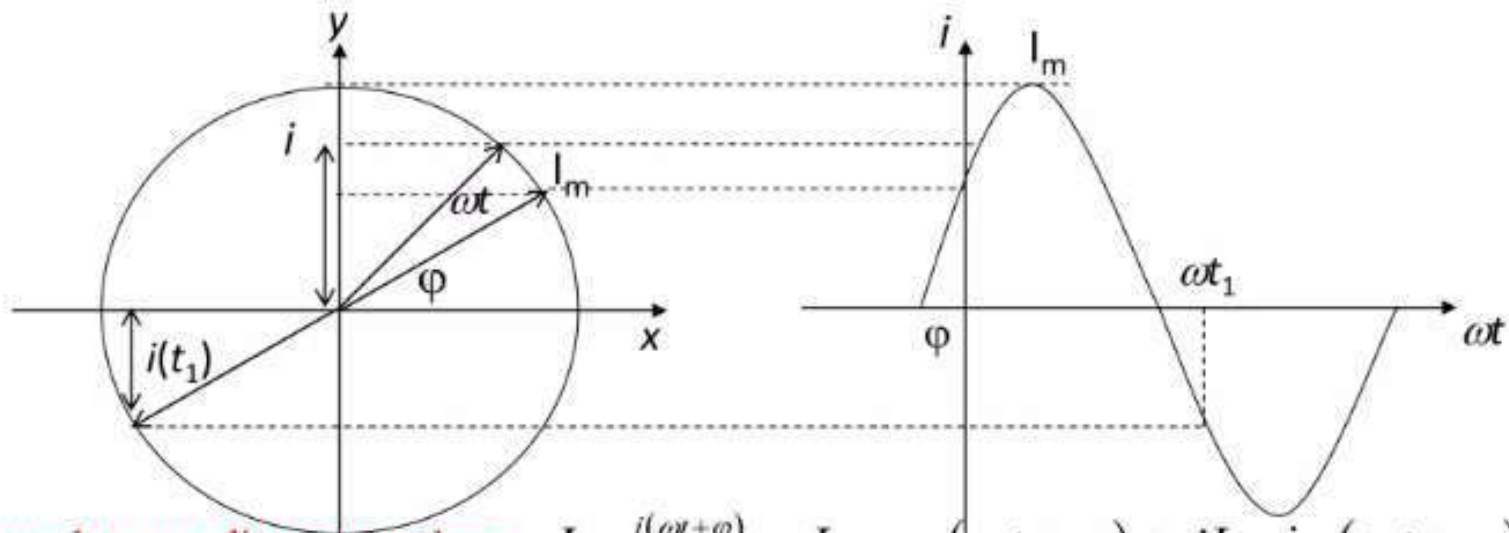

A complex coordinates number:  $I_m e^{j(\omega t + \varphi)} = I_m \cos(\omega t + \varphi) + jI_m \sin(\omega t + \varphi)$

Real value:  $i(t) = I_m \sin(\omega t + \varphi) = \text{Imag} \left( I_m e^{j(\omega t + \varphi)} \right)$

## Phasors

### Rotating Vector

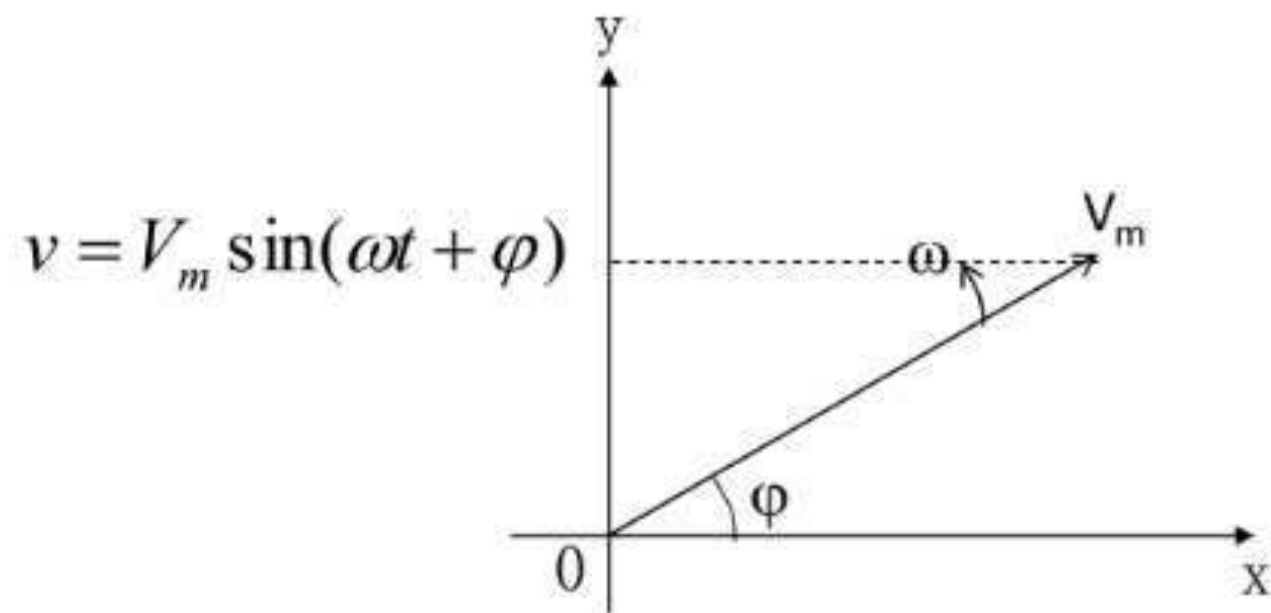

# Phasors

## Complex Numbers

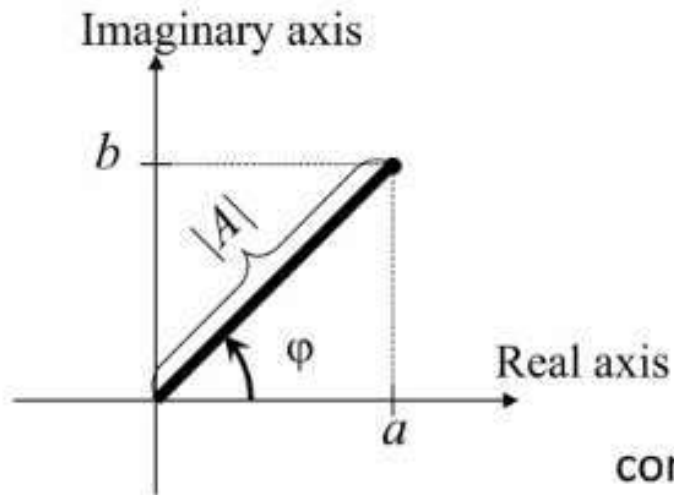

$A = a + jb$  — Rectangular Coordinates

$$A = |A|(\cos \varphi + j \sin \varphi)$$

$A = |A|e^{j\varphi}$  — Polar Coordinates

conversion:

$$A = a + jb \rightarrow A = |A|e^{j\varphi} \quad \begin{cases} |A| = \sqrt{a^2 + b^2} \\ \varphi = \arctg \frac{b}{a} \end{cases}$$

$$|A|e^{j\varphi} \rightarrow a + jb \quad \begin{cases} a = |A| \cos \varphi \\ b = |A| \sin \varphi \end{cases}$$

$$e^{\pm j90^\circ} = \cos 90^\circ \pm j \sin 90^\circ = 0 \pm j = \pm j$$

---

## Phasors

### Complex Numbers

#### Arithmetic With Complex Numbers

Addition:  $A = a + jb$ ,  $B = c + jd$ ,  $A + B = (a + c) + j(b + d)$

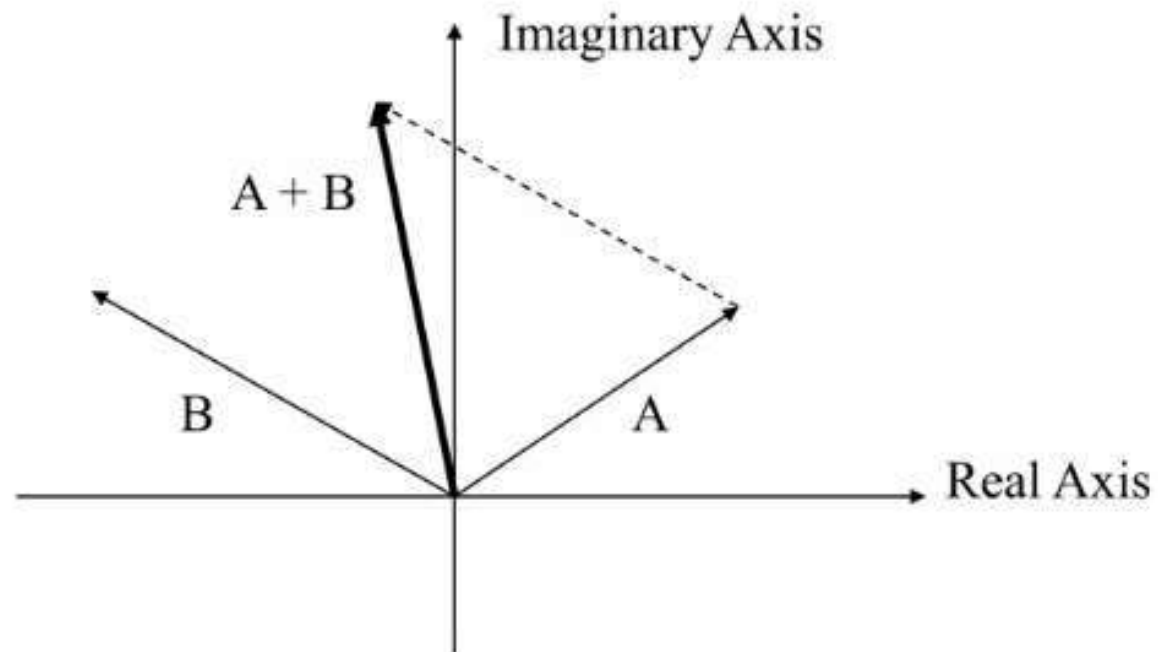

# Phasors

## Complex Numbers

### Arithmetic With Complex Numbers

Subtraction :  $A = a + jb$ ,  $B = c + jd$ ,  $A - B = (a - c) + j(b - d)$

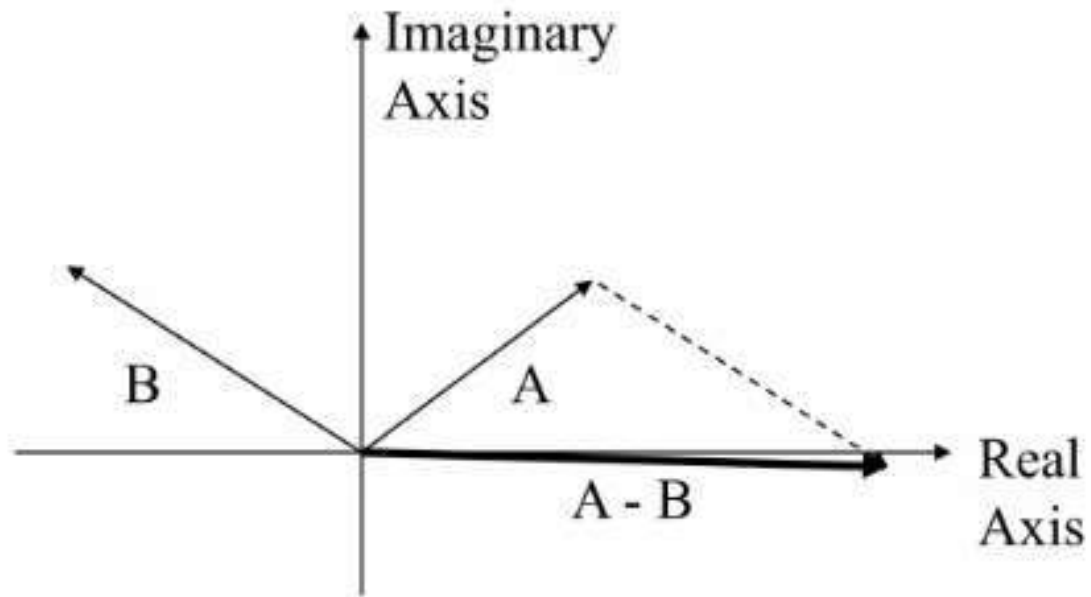

# Phasors

## Complex Numbers

### Arithmetic With Complex Numbers

Multiplication :  $A = A_m \angle \varphi_A$ ,  $B = B_m \angle \varphi_B$

$$A \times B = (A_m \times B_m) \angle (\varphi_A + \varphi_B)$$

Division:  $A = A_m \angle \varphi_A$ ,  $B = B_m \angle \varphi_B$

$$A / B = (A_m / B_m) \angle (\varphi_A - \varphi_B)$$

## Phasors

### Phasors

A phasor is a complex number that represents the magnitude and phase of a sinusoid:

$$i_m \cos(\omega t + \varphi) \iff \bar{I} = I_m \angle \varphi$$

### Phasor Diagrams

- A phasor diagram is just a graph of several phasors on the complex plane (using real and imaginary axes).
- A phasor diagram helps to visualize the relationships between currents and voltages.

## Phasors

### Complex Exponentials

$$A = |A|e^{j\varphi}$$

$$Ae^{j\omega t} = |A|e^{j(\omega t + \varphi)} = |A|\cos(\omega t + \varphi) + j|A|\sin(\omega t + \varphi)$$

$$\operatorname{Re}\{Ae^{j\omega t}\} = |A|\cos(\omega t + \varphi)$$

- A real-valued sinusoid is the real part of a complex exponential.
- Complex exponentials make solving for AC steady state an algebraic problem.

# *Phasor Relationships for R, L and C*

## Outline:

I-V Relationship for R, L and C,

Power conversion

## Phasor Relationships for R, L and C

Resistor •  $v \sim i$  relationship for a resistor

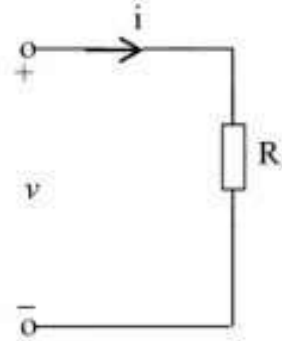

Suppose  $v = V_m \sin \omega t$

$$i = \frac{v}{R} = \frac{V_m}{R} \sin \omega t = I_m \sin \omega t$$

Relationship between RMS:  $I = \frac{V}{R}$

Wave and Phasor diagrams:

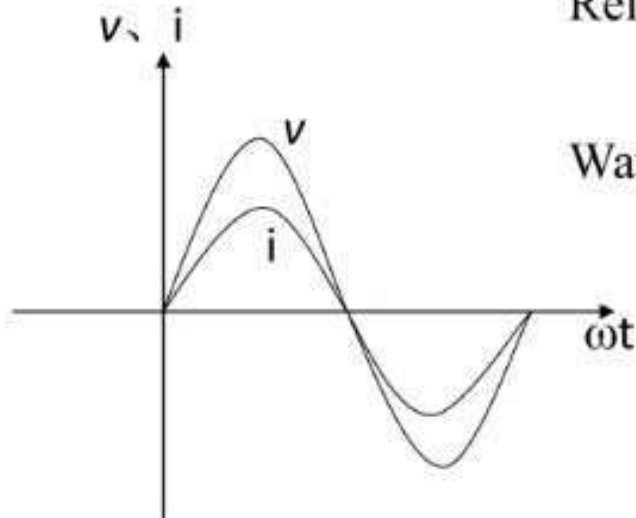

A phasor diagram showing two horizontal vectors pointing to the right. The upper vector is labeled 'I' with a dot above it, and the lower vector is labeled 'V' with a dot above it. Below the vectors, the equation  $I = \frac{V}{R}$  is written, where 'I' and 'V' have dots above them.

## Phasor Relationships for R, L and C

Resistor • Time domain → Frequency domain

$$\begin{array}{l} v(t) = V_m \cos(\omega t + \theta) \\ i(t) = I_m \cos(\omega t + \phi) \end{array} \quad \begin{array}{l} V(t) = Ri(t) \\ \longrightarrow \end{array} \quad \begin{array}{l} V_m e^{j(\omega t + \theta)} = RI_m e^{j(\omega t + \phi)} \\ V_m e^{j\theta} = RI_m e^{j\phi} \\ V_m \angle \theta = RI_m \angle \phi \\ \underline{V} = R\underline{I} \end{array}$$

With a resistor  $\theta = \phi$ ,  $v(t)$  and  $i(t)$  are in phase .

## Phasor Relationships for R, L and C

Resistor

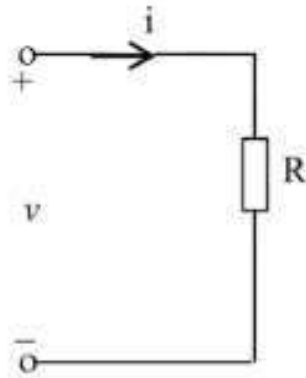

### • Power

#### • Transient Power

$$p = vi = V_m \sin \omega t \cdot I_m \sin \omega t = I_m V_m \sin^2 \omega t$$

$$= \frac{I_m V_m}{2} (1 - \cos 2\omega t) = IV - IV \cos 2\omega t$$

Note:  $I$  and  $V$  are RMS values.

$$P > 0$$

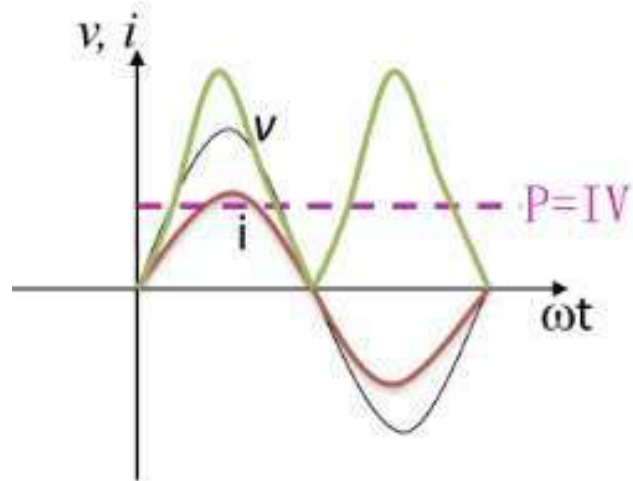

#### • Average Power

$$P = \frac{1}{T} \int_0^T p dt = \frac{1}{T} \int_0^T VI(1 - \cos 2\omega t) dt = VI$$

$$P = IV = I^2 R = \frac{V^2}{R}$$

## Phasor Relationships for R, L and C

Resistor

$$v = 311 \sin 314t \quad , \quad R = 10\Omega, \quad \text{Find } i \text{ and } P$$

$$V = \frac{V_m}{\sqrt{2}} = \frac{311}{\sqrt{2}} = 220(V)$$

$$I = \frac{V}{R} = \frac{220}{10} = 22(A)$$

$$i = 22\sqrt{2} \sin 314t \quad P = IV = 220 \times 22 = 4840 (W)$$

## Phasor Relationships for R, L and C

Inductor

●  $v \sim i$  relationship

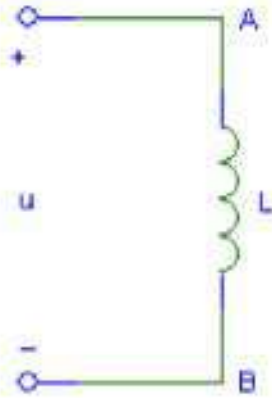

$$v = v_{AB} = L \frac{di}{dt}$$

Suppose  $i = I_m \sin \omega t$

$$\begin{aligned} v &= L \frac{di}{dt} = L \frac{d(I_m \sin \omega t)}{dt} = I_m \omega L \cos \omega t \\ &= I_m \omega L \sin(\omega t + 90^\circ) \\ &= V_m \sin(\omega t + 90^\circ) \end{aligned}$$

$$i = \frac{1}{L} \int_{-\infty}^t v dt = \frac{1}{L} \int_{-\infty}^0 v dt + \frac{1}{L} \int_0^t v dt = i_0 + \frac{1}{L} \int_0^t v dt$$

## Phasor Relationships for R, L and C

Inductor

●  $v \sim i$  relationship

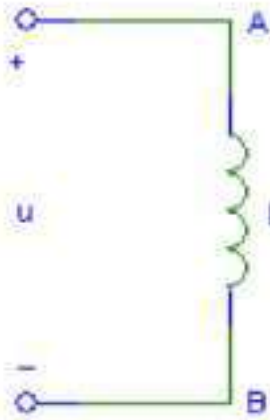

$$v = L \frac{di}{dt} = I_m \omega L \sin(\omega t + 90^\circ) = V_m \sin(\omega t + 90^\circ)$$

$$V_m = I_m \omega L$$

Relationship between RMS:  $V = I \omega L$

$$I = \frac{V}{\omega L} \longrightarrow X_L = \omega L = 2\pi f L \quad (\Omega)$$

$$\longrightarrow X_L \propto f$$

For DC,  $f = 0$ ,  $\rightarrow X_L = 0$ .

$\longrightarrow v(t)$  leads  $i(t)$  by  $90^\circ$ , or  $i(t)$  lags  $v(t)$  by  $90^\circ$

## Phasor Relationships for R, L and C

Inductor      ●  $v \sim i$  relationship

Wave and Phasor diagrams:

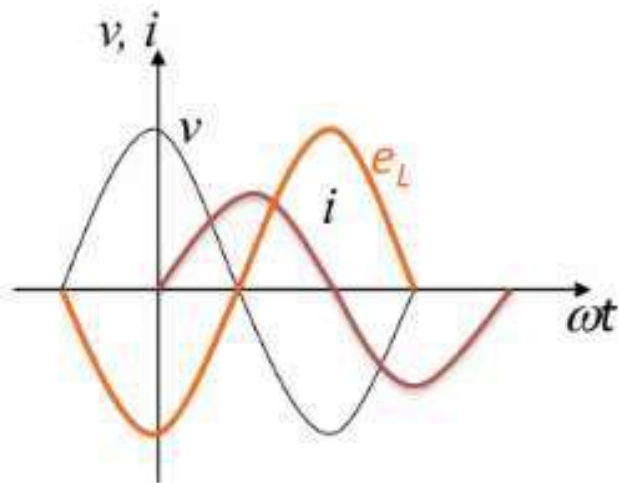

$$\mathcal{I} = jX_L \mathcal{V}$$

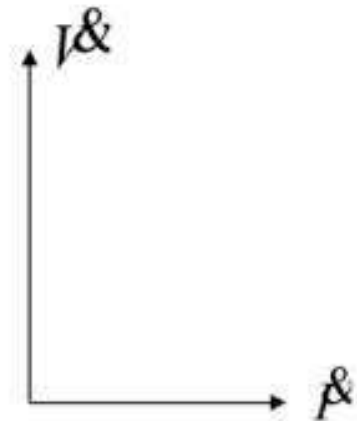

## Phasor Relationships for R, L and C

Inductor

### • Power

$$\begin{aligned}
 p &= vi = V_m \sin(\omega t + 90^\circ) I_m \sin \omega t = V_m I_m \cos \omega t \cdot \sin \omega t \\
 &= \frac{V_m I_m}{2} \sin 2\omega t = VI \sin 2\omega t
 \end{aligned}$$

$$\begin{aligned}
 \text{Energy stored: } W &= \int_0^t v i dt = \int_0^i L i di = \frac{1}{2} L i^2 \\
 W_{\max} &= \frac{1}{2} L I_m^2 = LI^2
 \end{aligned}$$

$$\text{Average Power } P = \frac{1}{T} \int_0^T p dt = \frac{1}{T} \int_0^T VI \sin 2\omega t dt = 0$$

$$\text{Reactive Power } Q = IV = I^2 X_L = \frac{V^2}{X_L} \quad (\text{Var})$$

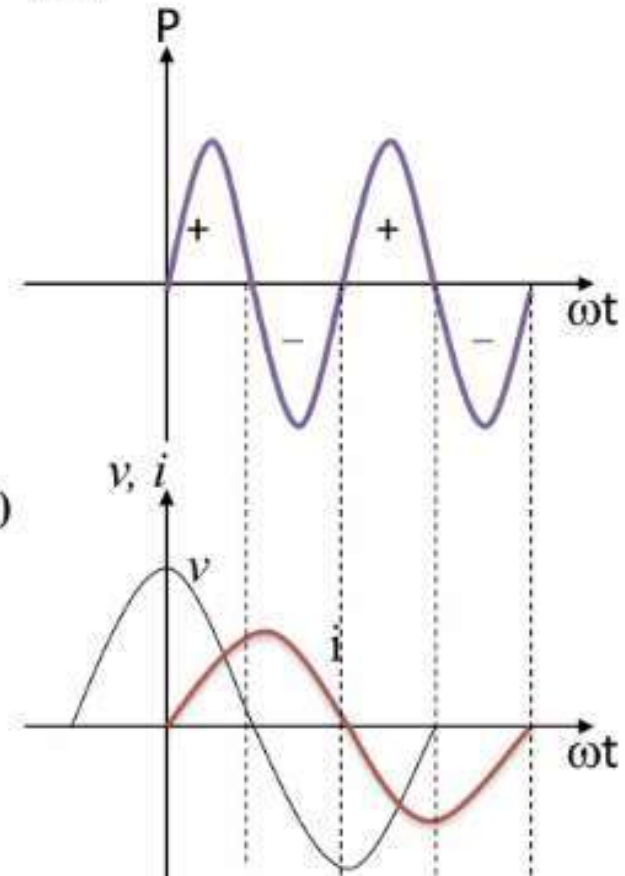

## Phasor Relationships for R, L and C

Inductor

$L = 10\text{mH}$ ,  $v = 100\sin\omega t$ , Find  $i_L$  when  $f = 50\text{Hz}$  and  $50\text{kHz}$ .

$$X_L = 2\pi fL = 2\pi \times 50 \times 10 \times 10^{-3} = 3.14(\Omega)$$

$$I_{50} = \frac{V}{X_L} = \frac{100 / \sqrt{2}}{3.14} = 22.5(A)$$

$$i_L(t) = 22.5\sqrt{2} \sin(\omega t - 90^\circ)A$$

$$X_L = 2\pi fL = 2\pi \times 50 \times 10^3 \times 10 \times 10^{-3} = 3140(\Omega)$$

$$I_{50k} = \frac{V}{X_L} = \frac{100 / \sqrt{2}}{3.14} = 22.5(mA)$$

$$i_L(t) = 22.5\sqrt{2} \sin(\omega t - 90^\circ)mA$$

## Phasor Relationships for R, L and C

Capacitor

•  $v \sim i$  relationship

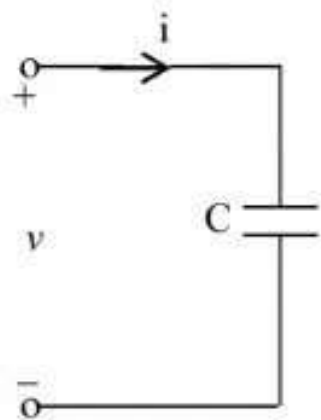

$$i = \frac{dq}{dt} = C \frac{dv}{dt}$$

Suppose:  $v = V_m \sin \omega t$

$$I_m = \omega C V_m$$

$$i = \omega C V_m \cos \omega t = \omega C V_m \sin(\omega t + 90^\circ) = I_m \sin(\omega t + 90^\circ)$$

$$v = \frac{1}{C} \int_{-\infty}^t i dt = \frac{1}{C} \int_{-\infty}^0 i dt + \frac{1}{C} \int_0^t i dt = v_0 + \frac{1}{C} \int_0^t i dt$$

⇒ Relationship between RMS:  $I = \omega C V = \frac{V}{\frac{1}{\omega C}} = \frac{V}{X_C}$

→  $X_C = \frac{1}{\omega C} = \frac{1}{2\pi f C} \quad (\Omega)$

⇒  $X_C \propto \frac{1}{f}$  For DC,  $f = 0$ ,  $\rightarrow X_C \rightarrow \infty$

⇒  $i(t)$  leads  $v(t)$  by  $90^\circ$ , or  $v(t)$  lags  $i(t)$  by  $90^\circ$

## Phasor Relationships for R, L and C

Capacitor •  $v \sim i$  relationship

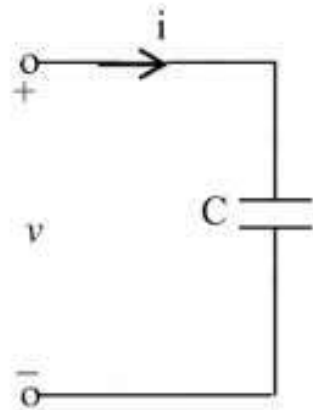

$$v(t) = V_m e^{j\omega t}$$

$$i(t) = C \frac{dv(t)}{dt} = C \frac{dV_m e^{j\omega t}}{dt} = j\omega C V_m e^{j\omega t}$$

Represent  $v(t)$  and  $i(t)$  as phasors:  $\underline{V} = j\omega C \underline{I} = \frac{\underline{I}}{jX_C}$

- The derivative in the relationship between  $v(t)$  and  $i(t)$  becomes a multiplication by  $-j/\omega C$  in the relationship between  $\underline{V}$  and  $\underline{I}$ .
- The time-domain differential equation has become the algebraic equation in the frequency-domain.
- Phasors allow us to express current-voltage relationships for inductors and capacitors much like we express the current-voltage relationship for a resistor.

## Phasor Relationships for R, L and C

Capacitor ●  $v \sim i$  relationship

Wave and Phasor diagrams:

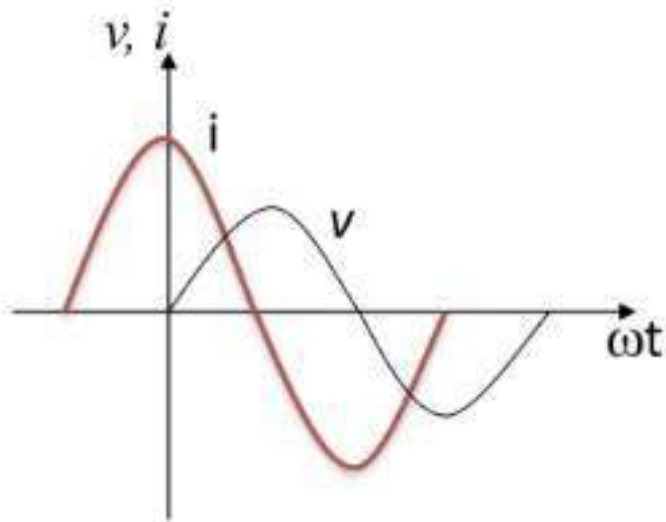

$$\mathbf{I} = -j\mathbf{I}X_C$$

A phasor diagram for a capacitor. The vertical axis is labeled  $\mathbf{V}$  and the horizontal axis is labeled  $\mathbf{I}$ . The current phasor  $\mathbf{I}$  is represented by a vector pointing along the positive horizontal axis. The voltage phasor  $\mathbf{V}$  is represented by a vector pointing along the positive vertical axis. This shows that the voltage is  $90^\circ$  ahead of the current.

## Phasor Relationships for R, L and C

Capacitor ● Power

$$p = vi = V_m \sin \omega t \cdot I_m \sin(\omega t + 90^\circ) = \frac{V_m I_m}{2} \sin 2\omega t = VI \sin 2\omega t$$

Energy stored:

$$W = \int_0^t v i dt = \int_0^v v \cdot C \cdot \frac{dv}{dt} \cdot dt = \int_0^v C v dv = \frac{1}{2} C v^2$$

$$W_{\max} = \frac{1}{2} C V_m^2 = C V^2$$

Average Power:  $P = 0$

Reactive Power  $Q = IV = I^2 X_C = \frac{V^2}{X_C}$  (Var)

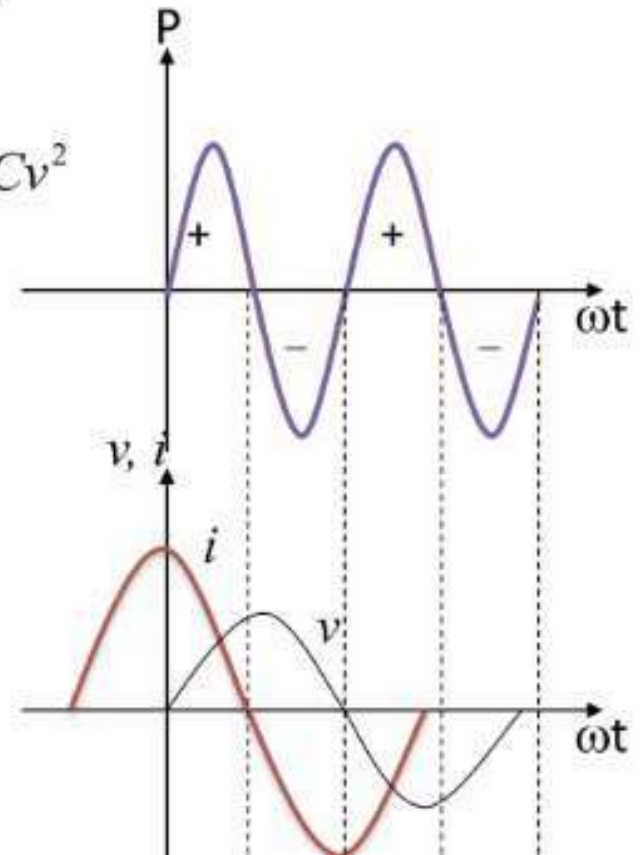

## Phasor Relationships for R, L and C

### Capacitor

Suppose  $C=20\mu\text{F}$ , AC source  $v=100\sin\omega t$ , Find  $X_C$  and  $I$  for  $f=50\text{Hz}$ ,  $50\text{kHz}$ .

$$f = 50\text{Hz} \rightarrow X_c = \frac{1}{\omega C} = \frac{1}{2\pi f C} = 159\ \Omega$$

$$I = \frac{V}{X_c} = \frac{V_m}{\sqrt{2}X_c} = 0.44\text{A}$$

$$f = 50\text{KHz} \rightarrow X_c = \frac{1}{\omega C} = \frac{1}{2\pi f C} = 0.159\ (\Omega)$$

$$I = \frac{V}{X_c} = \frac{V_m}{\sqrt{2}X_c} = 440\text{A}$$

## ✓ Phasor Relationships for R, L and C

Review (*v – i Relationship*)

*Time domain*

  $v = R \cdot i$   
R

  $v_L = L \frac{di}{dt}$   
L

  $i_C = C \frac{dv}{dt}$   
C

*Frequency domain*

$\mathcal{V} = R \cdot \mathcal{I}$ ,  $v$  and  $i$  are in phase.

$\mathcal{V} = j\omega L \cdot \mathcal{I}$ ,  $X_L = \omega L$ ,  $v$  leads  $i$  by  $90^\circ$ .

$\mathcal{I} = \frac{1}{j\omega C} \cdot \mathcal{V}$ ,  $X_C = \frac{1}{\omega C}$ ,  $v$  lags  $i$  by  $90^\circ$ .

## Phasor Relationships for R, L and C

### Summary:

- R:  $X_R = R$   $\Delta\varphi = 0$
- L:  $X_L = \omega L = 2\pi fL \propto f$   $\Delta\varphi = \varphi_v - \varphi_i = \frac{\pi}{2}$
- C:  $X_C = \frac{1}{\omega c} = \frac{1}{2\pi f c} \propto \frac{1}{f}$   $\Delta\varphi = \varphi_v - \varphi_i = -\frac{\pi}{2}$
- $V = IX$

- Frequency characteristics of an Ideal Inductor and Capacitor:

A capacitor is an *open circuit* to DC currents;

A Inductor is a *short circuit* to DC currents.

# Impedance ( $Z$ )

## Outline:

Complex currents and voltages.

Impedance

Phasor Diagrams

## Impedance (Z)

Complex voltage, Complex current, Complex Impedance

- AC steady-state analysis using phasors allows us to express the relationship between current and voltage using a formula that looks like Ohm's law:

$$\mathcal{V} = \mathcal{I}Z$$

'Z' is called impedance measured in ohms ( $\Omega$ )

$$\mathcal{V} = V_m e^{j\phi_v} = V_m \angle \phi_v$$

$$\mathcal{I} = I_m e^{j\phi_i} = I_m \angle \phi_i$$

$$Z = \frac{\mathcal{V}}{\mathcal{I}} = \frac{V_m}{I_m} e^{j(\phi_v - \phi_i)} = |Z| e^{j\phi} = |Z| \angle \phi$$

## Impedance (Z)

### Complex Impedance

$$Z = \frac{\mathcal{V}}{\mathcal{I}} = \frac{V_m}{I_m} e^{j(\varphi_v - \varphi_i)} = |Z| e^{j\varphi} = |Z| \angle \varphi$$

- ❖ Complex impedance describes the relationship between the voltage across an element (expressed as a phasor) and the current through the element (expressed as a phasor).
- ❖ Impedance is a complex number and is *not a phasor* (why?).
- ❖ Impedance depends on frequency.

## Impedance (Z)

### Complex Impedance

Resistor—The impedance is  $R$

$$Z_R = R \quad \Delta\varphi = 0; \text{ or } Z_R = R \angle 0$$

Capacitor—The impedance is  $1/j\omega C$

$$Z_c = \frac{1}{\omega C} e^{-j\frac{\pi}{2}} = \frac{-j}{\omega C} = -jX_c \quad \text{or} \quad Z_c = \frac{1}{\omega C} \angle -90^\circ$$

$$(\Delta\varphi = \varphi_v - \varphi_i = -\frac{\pi}{2})$$

Inductor—The impedance is  $j\omega L$

$$Z_L = \omega L e^{j\frac{\pi}{2}} = j\omega L = jX_L \quad \text{or} \quad Z_L = \omega L \angle 90^\circ$$

$$(\Delta\varphi = \varphi_v - \varphi_i = \frac{\pi}{2})$$

# Impedance (Z)

## Complex Impedance

Impedance in series/parallel can be combined as resistors.

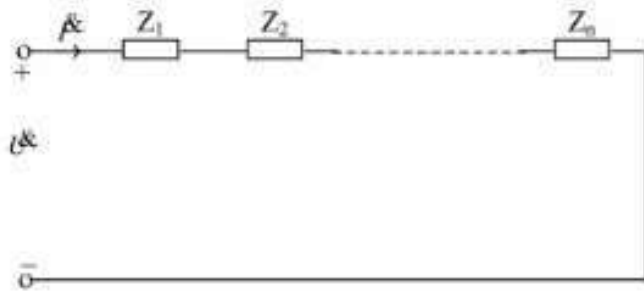

$$Z = Z_1 + Z_2 + \dots + Z_n = \sum_{k=1}^n Z_k$$

Voltage divider:

$$V_i = I \frac{Z_i}{\sum_{k=1}^n Z_k}$$

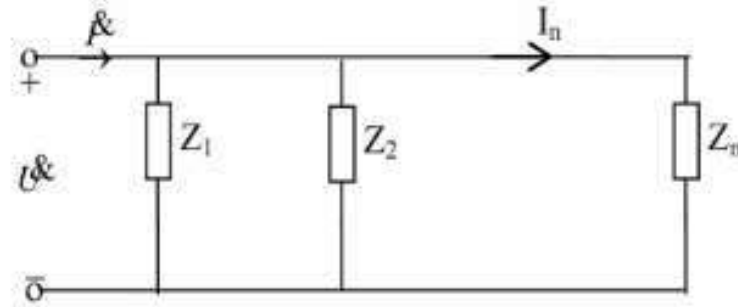

$$\frac{1}{Z} = \frac{1}{Z_1} + \frac{1}{Z_2} + \dots + \frac{1}{Z_n} = \sum_{k=1}^n \frac{1}{Z_k}$$

Current divider:

$$I_1 = I \frac{Z_2}{Z_1 + Z_2} \quad I_2 = I \frac{Z_1}{Z_1 + Z_2}$$

## Impedance (Z)

### Complex Impedance

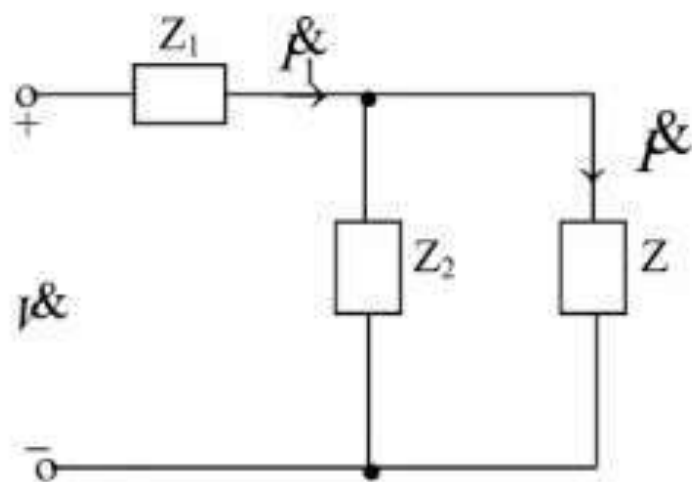

$$I_2 = I_1 \frac{Z_2}{Z + Z_2}$$

$$I_1 = \frac{I}{Z_1 + \left( \frac{1}{Z_2} + \frac{1}{Z} \right)^{-1}} = \frac{I(Z + Z_2)}{ZZ_1 + Z_2Z_1 + ZZ_2}$$

$$I_2 = \frac{IZ_2}{ZZ_1 + Z_2Z_1 + ZZ_2}$$

## Impedance (Z)

### Complex Impedance

Phasors and complex impedance allow us to use Ohm's law with complex numbers to compute current from voltage and voltage from current

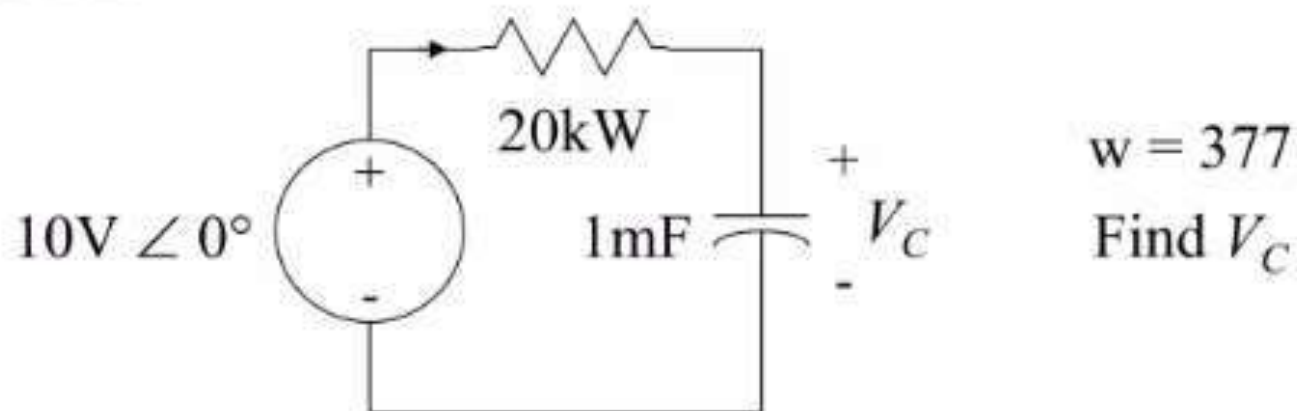

- How do we find  $V_C$ ?
- First compute impedances for resistor and capacitor:

$$Z_R = 20k\Omega = 20k\Omega \angle 0^\circ$$

$$Z_C = 1/j(377 * 1mF) = 2.65k\Omega \angle -90^\circ$$

## ✓ Impedance (Z)

### Complex Impedance

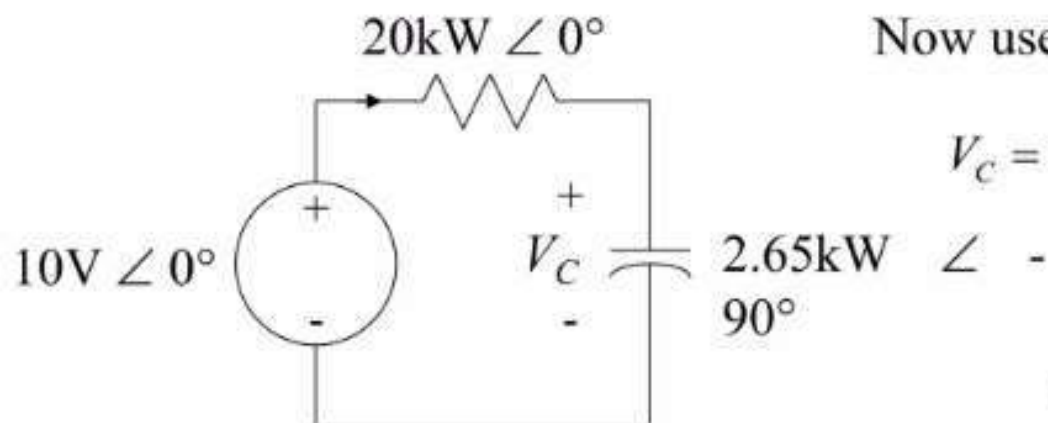
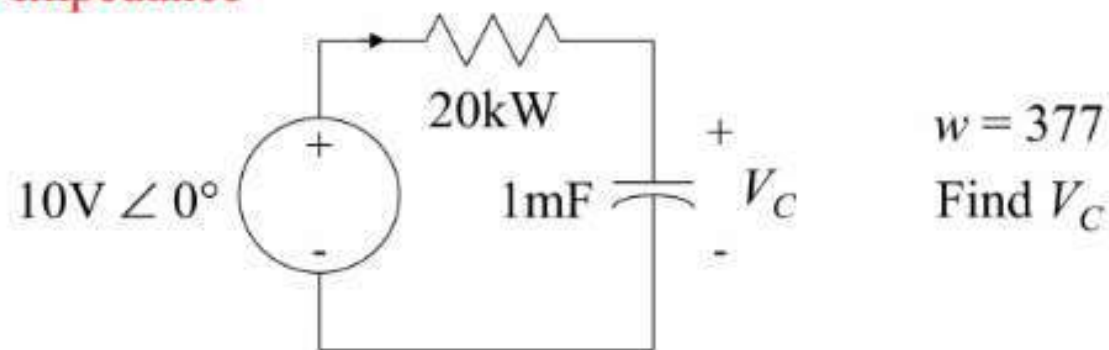

Now use the voltage divider to find  $V_C$ :

$$V_C = 10V \angle 0^\circ \left( \frac{2.65k\Omega \angle -90^\circ}{2.65k\Omega \angle -90^\circ + 20k\Omega \angle 0^\circ} \right)$$

$$\begin{aligned}
 V_C &= 10V \angle 0^\circ \frac{2.65 \angle -90^\circ}{20.17 \angle -7.54^\circ} \\
 &= 1.31V \angle -82.46^\circ
 \end{aligned}$$

## ✓ Impedance (Z)

### Complex Impedance

Impedance allows us to use the same solution techniques for AC steady state as we use for DC steady state.

- All the analysis techniques we have learned for the linear circuits are applicable to compute phasors
  - KCL & KVL
  - node analysis / loop analysis
  - Superposition
  - Thevenin equivalents / Norton equivalents
  - source exchange
- The only difference is that now complex numbers are used.

## Impedance (Z)

### Kirchhoff's Laws

KCL and KVL hold as well in phasor domain.

$$\text{KCL: } \sum_{k=1}^n i_k = 0 \quad i_k - \text{Transient current of the } \#k \text{ branch}$$

$$\sum_{k=1}^n \mathcal{I}_k = 0$$

$$\text{KVL: } \sum_{k=1}^n v_k = 0 \quad v_k - \text{Transient voltage of the } \#k \text{ branch}$$

$$\sum_{k=1}^n \mathcal{V}_k = 0$$

## Impedance (Z)

### Admittance

- $I = YV$ ,  $Y$  is called admittance, the reciprocal of impedance, measured in Siemens (S)
- Resistor:
  - The admittance is  $1/R$
- Inductor:
  - The admittance is  $1/j\omega L$
- Capacitor:
  - The admittance is  $j\omega C$

# Impedance (Z)

## Phasor Diagrams

- A phasor diagram is just a graph of several phasors on the complex plane (using real and imaginary axes).
- A phasor diagram helps to visualize the relationships between currents and voltages.

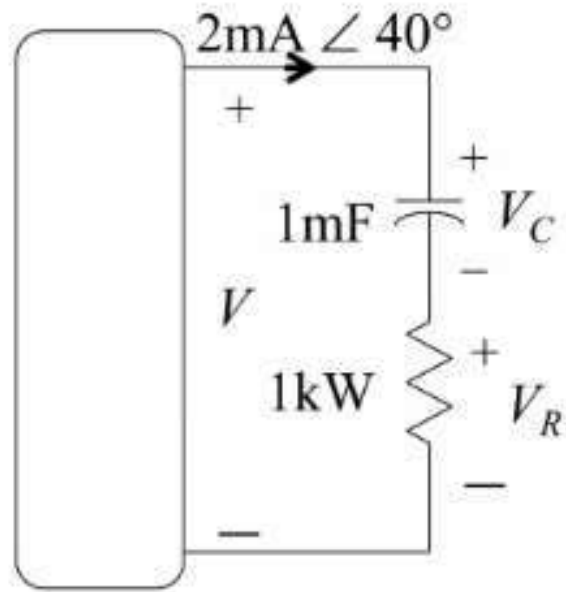

$$I = 2\text{mA} \angle 40^\circ, \quad V_R = 2\text{V} \angle 40^\circ$$

$$V_C = 5.31\text{V} \angle -50^\circ, \quad V = 5.67\text{V} \angle -29.37^\circ$$

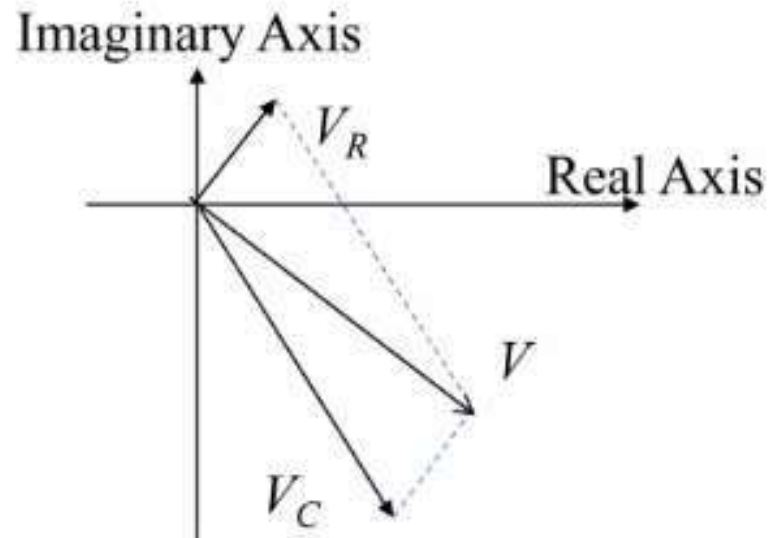

# Parallel and Series Resonance

## Outline:

RLC Circuit,

Series Resonance

Parallel Resonance

## Parallel and Series Resonance :

### Series RLC Circuit (2nd Order RLC Circuit )

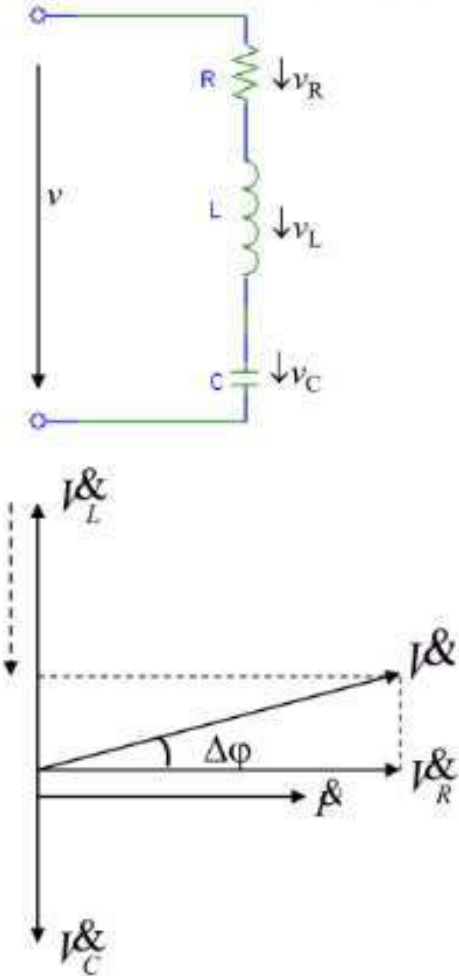

$$v = v_R + v_L + v_C$$

Phasor  $I = I_R + I_L + I_C$

$$V = \sqrt{V_R^2 + (V_L - V_C)^2}$$

$\Rightarrow$   $= \sqrt{(IR)^2 + (IX_L - IX_C)^2}$

$$= I\sqrt{R^2 + (X_L - X_C)^2}$$

$$= I\sqrt{R^2 + X^2} \quad (X = X_L - X_C)$$

$$= IZ$$

$$Z = \sqrt{R^2 + X^2} = \sqrt{R^2 + \left(\omega L - \frac{1}{\omega C}\right)^2}$$

## Parallel and Series Resonance :

### Series RLC Circuit

$$V = \sqrt{V_R^2 + (V_L - V_C)^2} = IZ \quad Z = \sqrt{R^2 + X^2} = \sqrt{R^2 + \left(\omega L - \frac{1}{\omega C}\right)^2}$$

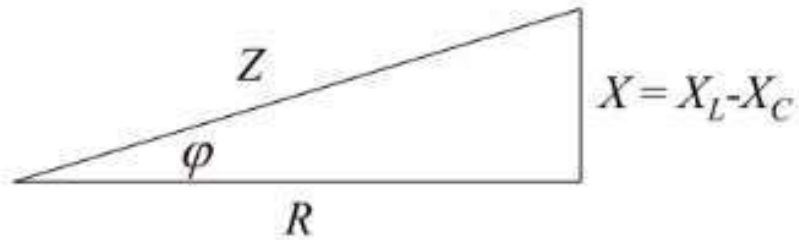

Phase difference:

$$= \tan^{-1} \frac{V_L - V_C}{V_R}$$

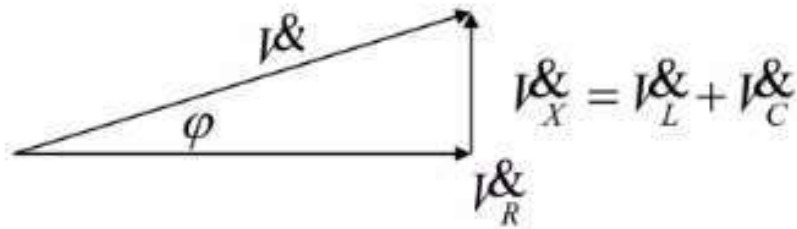

$$= \tan^{-1} \frac{X_L - X_C}{R}$$

$X_L > X_C \rightarrow \varphi > 0$ ,  $v$  leads  $i$  by  $\varphi$  — Inductance Circuit

$X_L < X_C \rightarrow \varphi < 0$ ,  $v$  lags  $i$  by  $\varphi$  — Capacitance Circuit

$X_L = X_C \rightarrow \varphi = 0$ ,  $v$  and  $i$  in phase — Resistors Circuit

## Parallel and Series Resonance :

### Series RLC Circuit

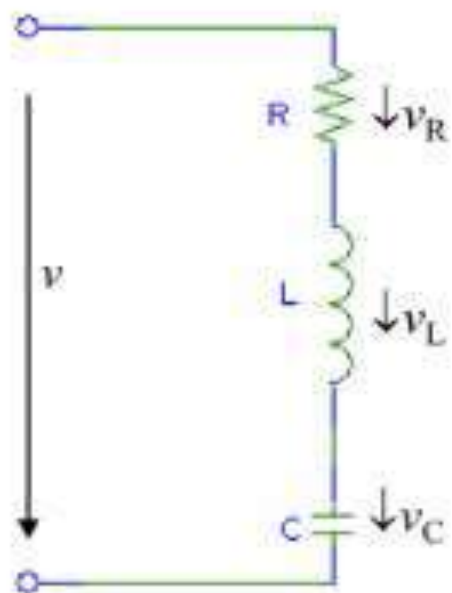

$$\begin{aligned}\vec{V} &= \vec{V}_R + \vec{V}_L + \vec{V}_C = \vec{I}R + j\vec{I}X_L - j\vec{I}X_C \\ &= \vec{I}[R + j(X_L - X_C)] = \vec{I}(R + jX) = \vec{I}Z\end{aligned}$$

$$\longrightarrow Z = \frac{\vec{V}}{\vec{I}} = R + j(X_L - X_C)$$

$$Z = R + jX = |Z| \angle \varphi \begin{cases} |Z| = \sqrt{R^2 + (X_L - X_C)^2} \\ \varphi = \tan^{-1} \frac{X_L - X_C}{R} \end{cases}$$

$$\varphi = \varphi_v - \varphi_i$$

## Parallel and Series Resonance :

### Series Resonance (2nd Order RLC Circuit )

$$\mathcal{I} = \mathcal{I}_R + \mathcal{I}_L + \mathcal{I}_C = \mathcal{I} + j\mathcal{I}X_L - j\mathcal{I}X_C \quad \varphi = \arctg \frac{V_L - V_C}{V_R} = \arctg \frac{X_L - X_C}{R}$$

When  $X_L = X_C$ ,  $\frac{1}{\omega C} = \omega L \rightarrow V_L = V_C \longrightarrow \omega_0 = \frac{1}{\sqrt{LC}}$  or  $f_0 = \frac{1}{2\pi\sqrt{LC}}$

Resonance condition Resonant frequency

$\longrightarrow V_R = V$  and  $\varphi = 0$  — **Series Resonance**

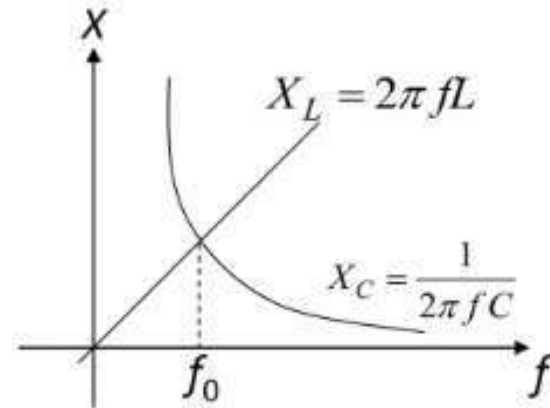
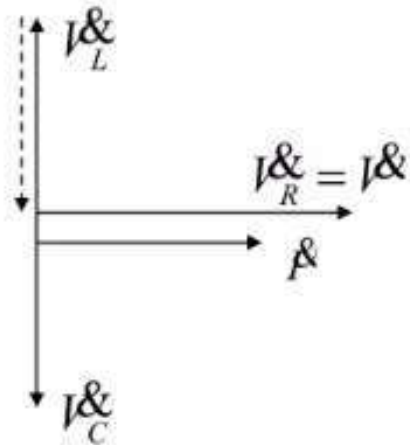

## Parallel and Series Resonance :

### Series Resonance

Resonance condition:  $X_L = X_C$  ( $\frac{1}{\omega C} = \omega L$ )  $\rightarrow V_L = V_C$

$$\bullet Z_0 = \sqrt{R^2 + (X_L - X_C)^2} = R \rightarrow I_0 = \frac{V}{Z_0} = \frac{V}{R}$$

$Z_{min}$ ; when  $V = \text{constant}$ ,  $I = I_{max} = I_0$

When,  $X_L = X_C \gg R \rightarrow I_0 X_L = I_0 X_C \gg I_0 R \rightarrow V_L = V_C \gg V$

• Quality factor  $Q$ ,

$$Q = \frac{V_L}{V} = \frac{V_C}{V} = \frac{X_L}{R} = \frac{X_C}{R}$$

## Parallel and Series Resonance :

### Parallel RLC Circuit

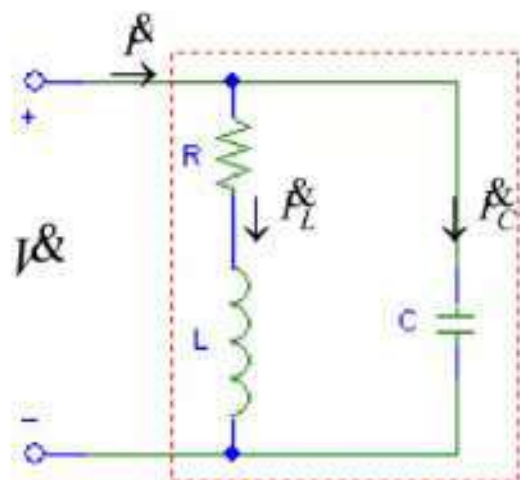

$$Y = \frac{1}{R + j\omega L} + \frac{1}{-j/\omega C} = \frac{1}{R + j\omega L} + j\omega C$$

$$= \frac{R - j\omega L}{(R + j\omega L)(R - j\omega L)} + j\omega C$$

$$= \frac{R}{R^2 + \omega^2 L^2} + j\left(\omega C - \frac{\omega L}{R^2 + \omega^2 L^2}\right)$$

When  $\left(\omega C - \frac{\omega L}{R^2 + \omega^2 L^2}\right) = 0$ ,  $Y_0 = \frac{R}{R^2 + \omega^2 L^2}$

$I$  In phase with  $V$

→ **Parallel Resonance**

Parallel Resonance frequency  $\omega_0 = \frac{1}{\sqrt{LC}} \sqrt{1 - \frac{CR^2}{L}}$

In generally  $R \ll X_L \longrightarrow \omega_0 = \frac{1}{\sqrt{LC}} \quad (f_0 = \frac{1}{2\pi\sqrt{LC}})$

→  $Z_{max} \quad I_{min} : \quad I = I_0 = VY_0 = V \frac{R}{R^2 + \omega_0^2 L^2} = V \frac{R}{R^2 + \frac{1}{LC} L^2} = V \frac{R}{R^2 + \frac{L}{C}} \approx \frac{RC}{L} V$

## Parallel and Series Resonance :

### Parallel RLC Circuit

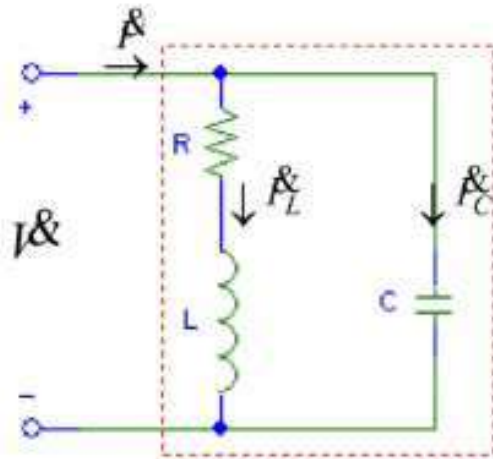

$$I_L = I_0 \frac{1}{R + j\omega_0 L} \approx -j \frac{I_0}{\omega_0 L} = -j \sqrt{\frac{C}{L}} I_0$$

$$I_C = j\omega_0 C I_0 = j \sqrt{\frac{C}{L}} I_0$$

$$|I_L| = |I_C| \gg |I_0| \approx 0 \longrightarrow Z \rightarrow \infty.$$

• Quality factor  $Q$ ,

$$Q = \frac{I_C}{I_0} = \frac{I_L}{I_0} = \frac{Y_L}{Y_0} = \frac{Y_C}{Y_0}$$

$$I_L = -jQ I_0 \quad I_C = jQ I_0$$

$$Q \approx \frac{\omega_0 L}{R} = \frac{1}{\omega_0 RC}$$

## Parallel and Series Resonance :

### Parallel RLC Circuit

#### Review

For sinusoidal circuit, Series :

$$v = v_1 + v_2$$

$$V \neq V_1 + V_2$$

?

Parallel :

$$i = i_1 + i_2$$

$$I \neq I_1 + I_2$$

Two Simple Methods:

Phasor Diagrams and Complex Numbers

# UNIT - 4

# INTRODUCTION:

- In electric network analysis, the fundamental rules are Ohm's Law and Kirchhoff's Laws. While these humble laws may be applied to analyze just about any circuit configuration (even if we have to resort to complex algebra to handle multiple unknowns), there are some —shortcut|| methods of analysis to make the math easier for the average human.
- As with any theorem of geometry or algebra, these network theorems are derived from fundamental rules. In this chapter, I'm not going to delve into the formal proofs of any of these theorems. If you doubt their validity, you can always empirically test them by setting up example circuits and calculating values using the —old|| (simultaneous equation) methods versus the —new|| theorems, to see if the answers coincide.
- Network theorems are also can be termed as network reduction techniques. Each and every theorem got its importance of solving network. Let us see some important theorems with DC and AC excitation with detailed procedures.

# TELLEGEN'S THEOREM:

- Dc Excitation: Tellegen's theorem states algebraic sum of all delivered power must be equal to sum of all received powers. According to Tellegen's theorem, the summation of instantaneous powers for the  $n$  number of branches in an electrical network is zero. Are you confused? Let's explain. Suppose  $n$  number of branches in an electrical network have  $i_1, i_2, i_3, \dots$  in respective instantaneous currents through them. These currents satisfy Kirchhoff's Current Law. Again, suppose these branches have instantaneous voltages across them are  $v_1, v_2, v_3, \dots, v_n$  respectively. If these voltages across these elements satisfy Kirchhoff Voltage Law then

This theorem can easily be explained by the following example:

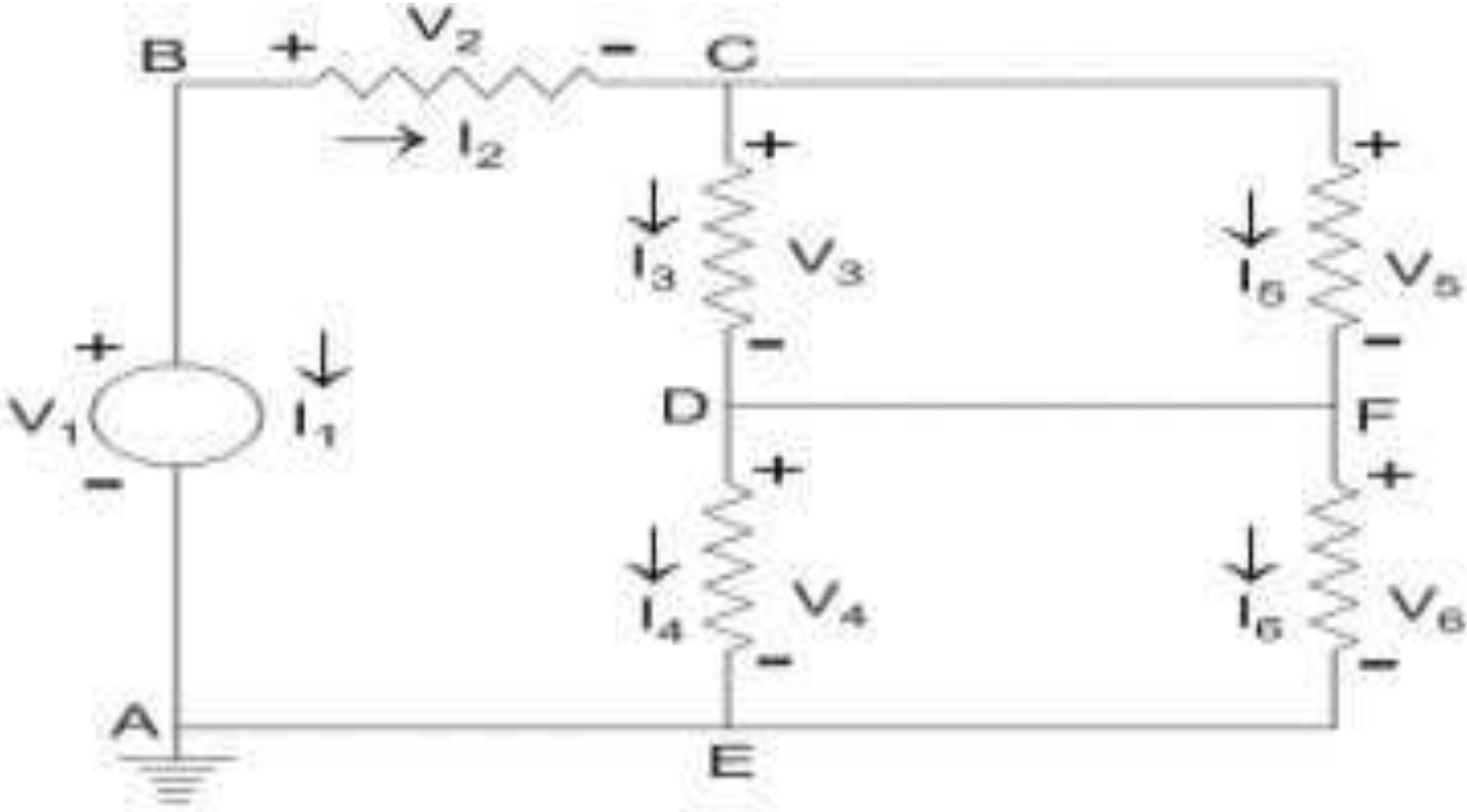

- In the network shown, arbitrary reference directions have been selected for all of the branch currents, and the corresponding branch voltages have been indicated, with positive reference direction at the tail of the current arrow. For this network, we will assume a set of branch voltages satisfy the Kirchhoff voltage law and a set of branch current satisfy Kirchhoff current law at each node.
- We will then show that these arbitrary assumed voltages and currents satisfy the equation.

$$\sum_{k=1}^n v_k \cdot i_k = 0$$

- And it is the condition of Tellegen's theorem. In the network shown in the figure, let  $v_1$ ,  $v_2$  and  $v_3$  be 7, 2 and 3 volts respectively. Applying Kirchhoff Voltage Law around loop ABCDEA. We see that  $v_4 = 2$  volt is required. Around loop CDFC,  $v_5$  is required to be 3 volt and around loop DFED,  $v_6$  is required to be 2. We next apply Kirchhoff's Current Law successively to nodes B, C and D. At node B let  $i_1 = 5$  A, then it is required that  $i_2 = -5$  A. At node C let  $i_3 = 3$  A and then  $i_5$  is required to be - 8. At node D assume  $i_4$  to be 4 then  $i_6$  is required to be - 9. Carrying out the operation of equation.
- We get,

$$7 \times 5 + 2 \times (-5) + 3 \times 3 + 2 \times 4 + 3 \times (-8) + 2 \times (-9) = 0$$

Hence **Tellegen's theorem** is verified.

# SUPER-POSITION THEOREM:

- DC: “ In an any linear , bi-lateral network consisting number of sources , response in any element(resistor) is given as sum of the individual Reponses due to individual sources, while other sources are non-operative”
- AC: “ In an any linear , bi-lateral network consisting number of sources , response in any element(impedance) is given as sum of the individual Reponses due to individual sources, while other sources are non-operative”

# Procedure of Superposition Theorem:

- Follow these steps in order to find the response in a particular branch using superposition theorem.
- **Step 1** – Find the response in a particular branch by considering one independent source and eliminating the remaining independent sources present in the network.
- **Step 2** – Repeat Step 1 for all independent sources present in the network.
- **Step 3** – Add all the responses in order to get the overall response in a particular branch when all independent sources are present in the network.

• Eg:

Let  $V = 6\text{v}$ ,  $I = 3\text{A}$ ,  $R_1 = 8\text{ ohms}$  and  $R_2 = 4\text{ ohms}$

Let us find current through 4 ohms using  $V$  source, while  $I$  is zero. Then equivalent circuit is

Let  $i_1$  is the current through 4 ohms,  $i_1 = V / (R_1+R_2)$

Let us find current through 4 ohms using  $I$  source, while  $V$  is zero. Then equivalent circuit is

Let  $i_2$  is the current through 4 ohms,  $i_2 = I \cdot R_1 / (R_1+R_2)$

Hence total current through 4 ohms is  $= I_1+I_2$  ( as both currents are in same direction or otherwise  $I_1-I_2$ )

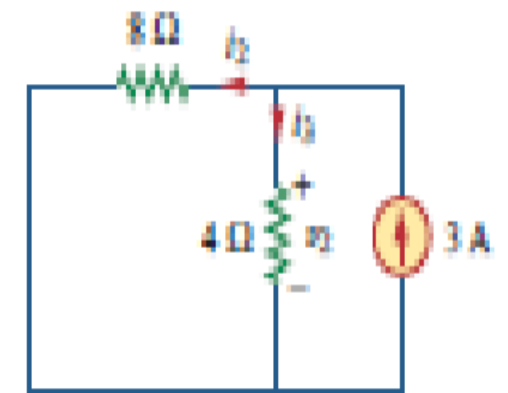
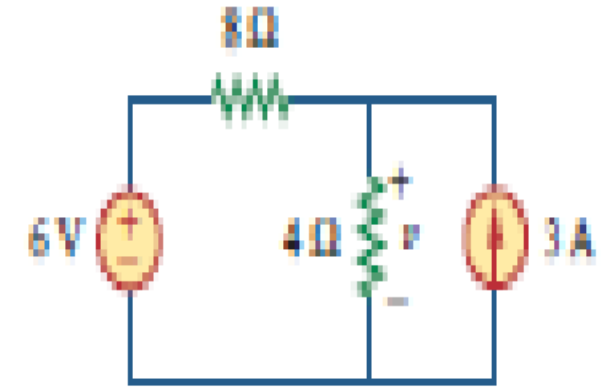

- Let us find current through 4 ohms using I source, while V is zero. Then equivalent circuit is

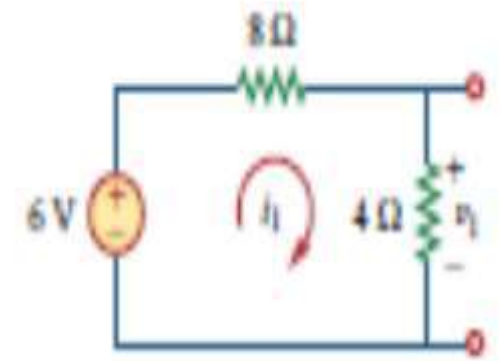

Let  $i_2$  is the current through 4 ohms,  $i_2 = I \cdot Z_1 / (Z_1 + Z_2)$   
 Hence total current through 4 ohms is  $= I_1 + I_2$  ( as both currents are in same direction or otherwise  $I_1 - I_2$ ).

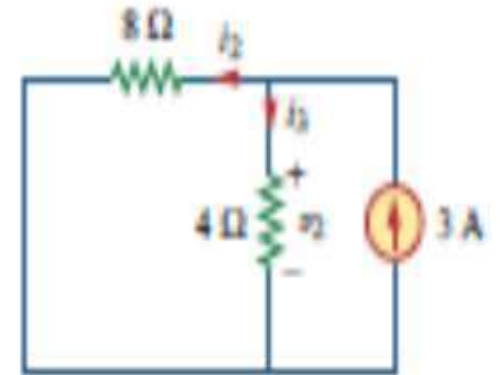

# RECIPROCITY THEOREM:

DC & AC: — In any linear bi-lateral network ratio of voltage in one mesh to current in other mesh is same even if their positions are inter-changed||.

Eg:

Find the total resistance of the circuit,  $R_t = R_1 + [R_2(R_3+R_L)] / R_2+R_3+R_L$ .

Hence source current,  $I = V_1 / R_t$ .

Current through  $R_L$  is  $I_1 = I \cdot R_2 / (R_2+R_3+R_L)$

Take the ratio of ,  $V_1 / I_1 ---1$

Draw the circuit by inter changing position of  $V_1$  and  $I$

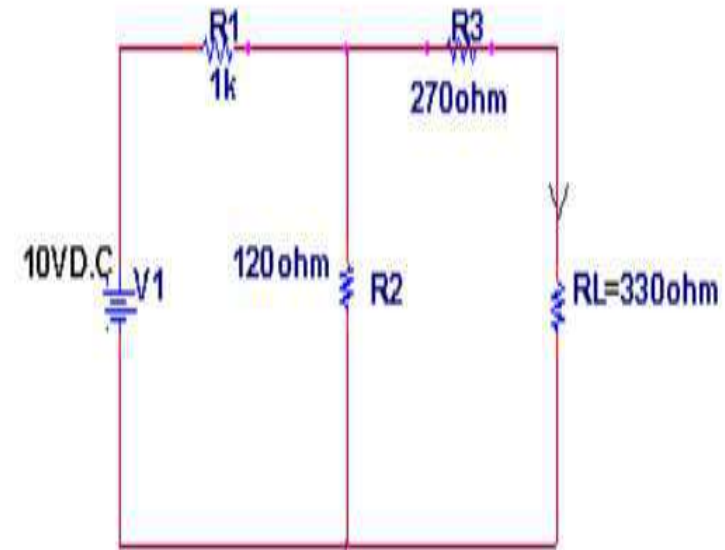

Find the total resistance of the circuit,  $R_t = (R_3 + R_L) + [R_2(R_1)] / R_2 + R_1$ .

Hence source current,  $I = V_1 / R_t$ .

Current through  $R_L$  is  $I_1 = I \cdot R_2 / (R_2 + R_1)$

Take the ratio of ,  $V_1 / I_1$  ---2

If ratio 1 = ratio 2, then circuit is said to be satisfy reciprocity

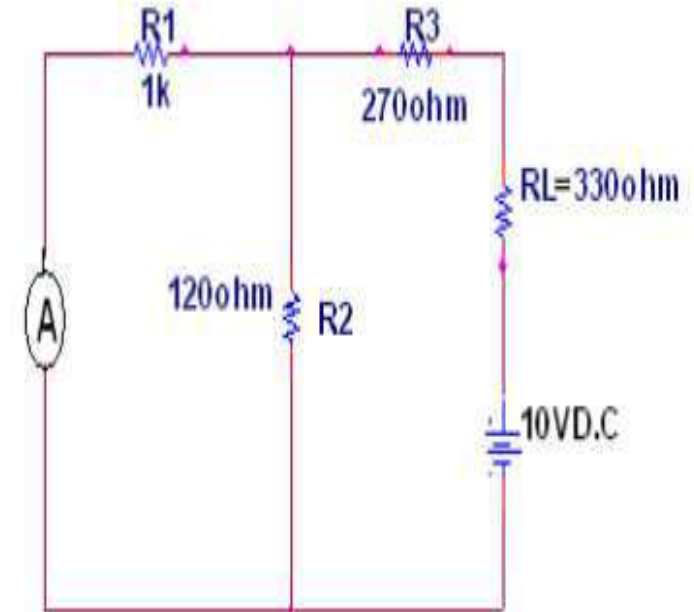

# THEVENIN'S THEOREM:

- **DC:** — An complex network consisting of number voltage and current sources and be replaced by simple series circuit consisting of equivalent voltage source in series with equivalent resistance, where equivalent voltage is called as open circuit voltage and equivalent resistance is called as Thevenin's resistance calculated across open circuit terminals while all energy sources are non-operative||
- **AC:** — An complex network consisting of number voltage and current sources and be replaced by simple series circuit consisting of equivalent voltage source in series with equivalent impedance, where equivalent voltage is called as open circuit voltage and equivalent impedance is called as Thevenin's impedance calculated across open circuit terminals while all energy sources are non-operative||

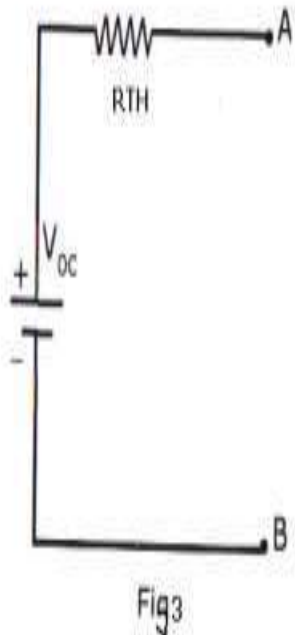
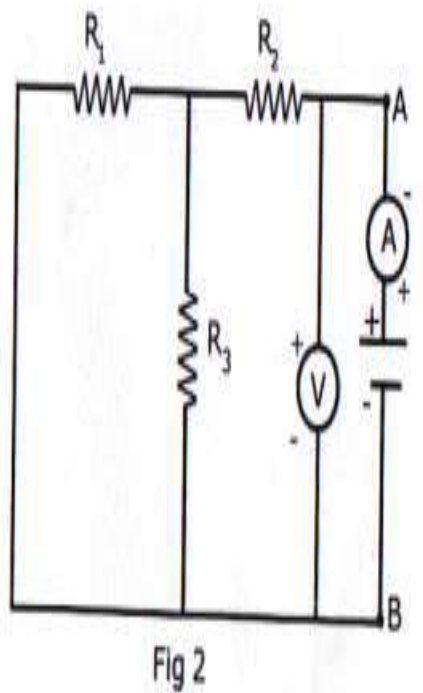
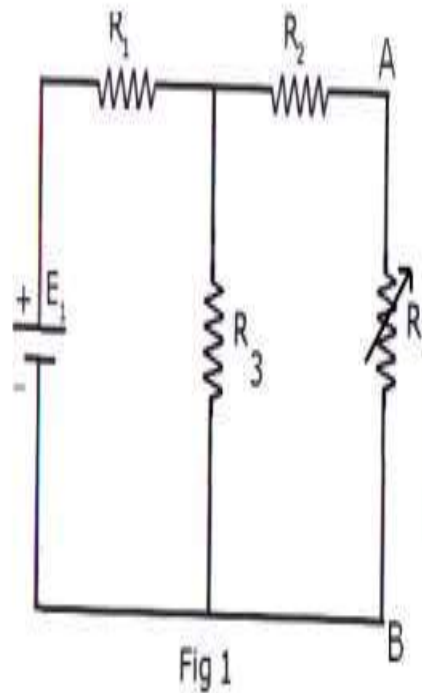

# NORTON'S THEOREM:

- **DC:** — An complex network consisting of number voltage and current sources and be replaced by simple parallel circuit consisting of equivalent current source in parallel with equivalent resistance, where equivalent current source is called as short circuit current and equivalent resistance is called as Norton's resistance calculated across open circuit terminals while all energy sources are non-operative||
- **AC:** —An complex network consisting of number voltage and current sources and be replaced by simple parallel circuit consisting of equivalent current source in parallel with equivalent impedance, where equivalent current source is called as short circuit current and equivalent impedance is called as Norton's impedance calculated across open circuit terminals while all energy sources are non-operative||

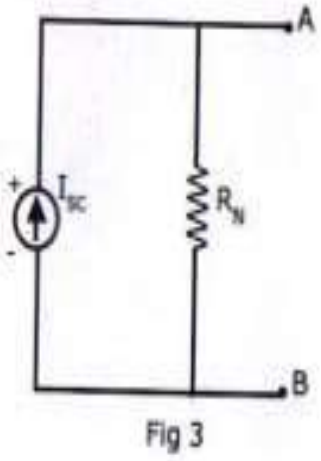
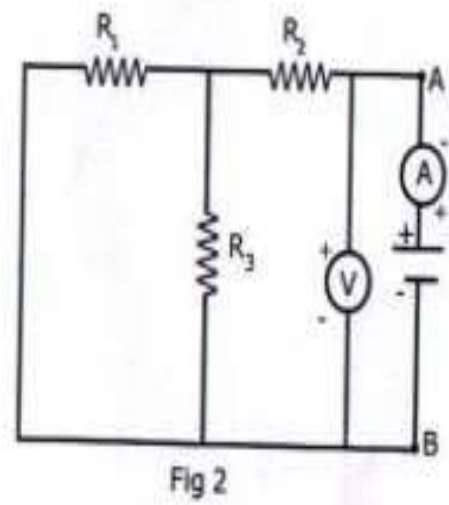
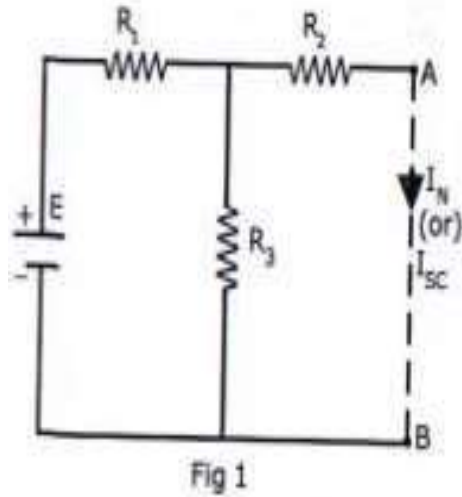

Here we need to find current through RL using Norton's theorem.

Short circuit the AB terminals to find the Norton's current.

Total resistance of circuit is,  $R_t = (R_2 \cdot R_3) / (R_2 + R_3) + R_1$

Source current,  $I = E / R_t$

Norton's current,  $I_N = I \cdot R_3 / (R_2 + R_3)$  ----1 from figure .1

Norton's resistance,  $R_N = (R_1 \cdot R_3) / (R_1 + R_3) + R_2$  ----2 from figure 2

# MAXIMUM POWER TRANSFER THEOREM:

- **DC:** “ In linear bi-lateral network maximum power can be transferred from source to load if load resistance is equal to source or thevenin’s or internal resistances.
- **AC:** “ In linear bi-lateral network maximum power can be transferred from source to load if load impedance is equal to complex conjugate of source or thevenin’s or internal impedances|| Eg:  
For the below circuit explain maximum power transfer theorem.

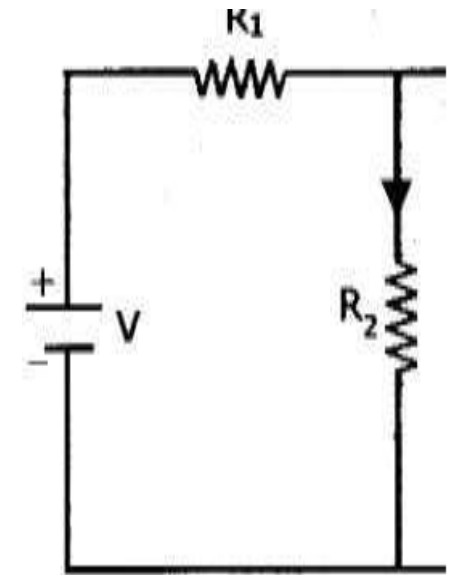

- Let  $I$  be the source current,  $I = V / (R_1 + R_2)$
- Power absorbed by load resistor is,  $P_L = I^2 \cdot R_2$   
 $= [ V / (R_1 + R_2) ]^2 \cdot R_2.$

To say that load resistor absorbed maximum power ,  $dP_L / dR_2 = 0$

When we solve above condition we get,  $R_2 = R_1.$

Hence maximum power absorbed by load resistor is,  $P_{Lmax} = V^2 / 4R_2.$

# MILLIMAN'S THEOREM:

- **DC:** " An complex network consisting of number of parallel branches , where each parallel branch consists of voltage source with series resistance, can be replaced with equivalent circuit consisting of one voltage source in series with equivalent resistance||

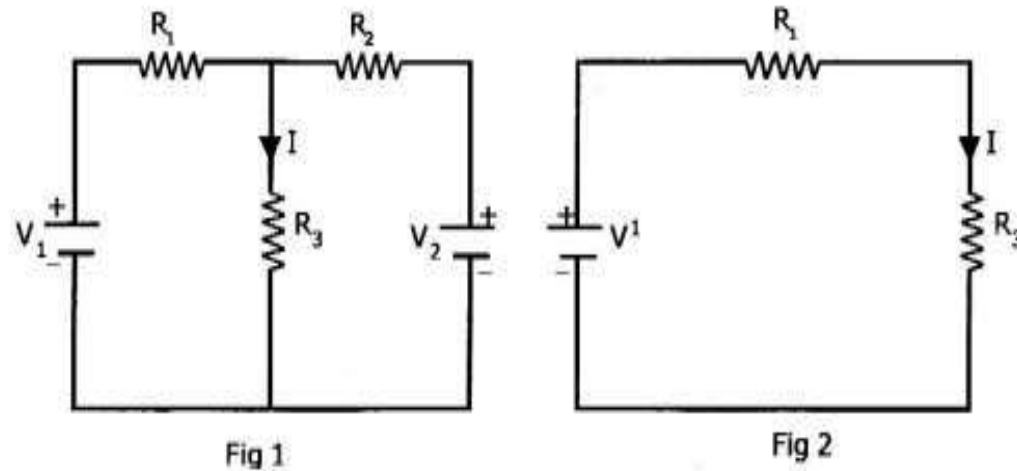

Where equivalent voltage source value is ,  $V' = \frac{(V_1G_1+V_2G_2+\dots+V_nG_n)}{G_1+G_2+\dots+G_n}$

Equivalent resistance is ,  $R' = 1 / ( G_1+G_2+\dots+G_n)$

**AC:** “ An complex network consisting of number of parallel branches , where each parallel branch consists of voltage source with series impedance, can be replaced with equivalent circuit consisting of one voltage source in series with equivalent impedance

Where equivalent voltage source value is ,  $V' = \frac{(V_1Y_1+V_2Y_2+\dots+V_nY_n)}{Y_1+Y_2+\dots+Y_n}$

Equivalent resistance is ,  $Z' = 1 / ( Y_1+Y_2+\dots+Y_n)$

# UNIT - 5

# Outline

- ❑ Recap of Three Phase System
- ❑ Three Phase Quantities: Line/Phase Voltage and Current
- ❑ Three Phase Power and Power Measurement

# THREE-PHASE SOURCES

- A typical three-phase system consists of three voltage sources connected to loads by three or four wires (or transmission lines).
- The voltage sources can be **either wye-connected or delta-connected**.

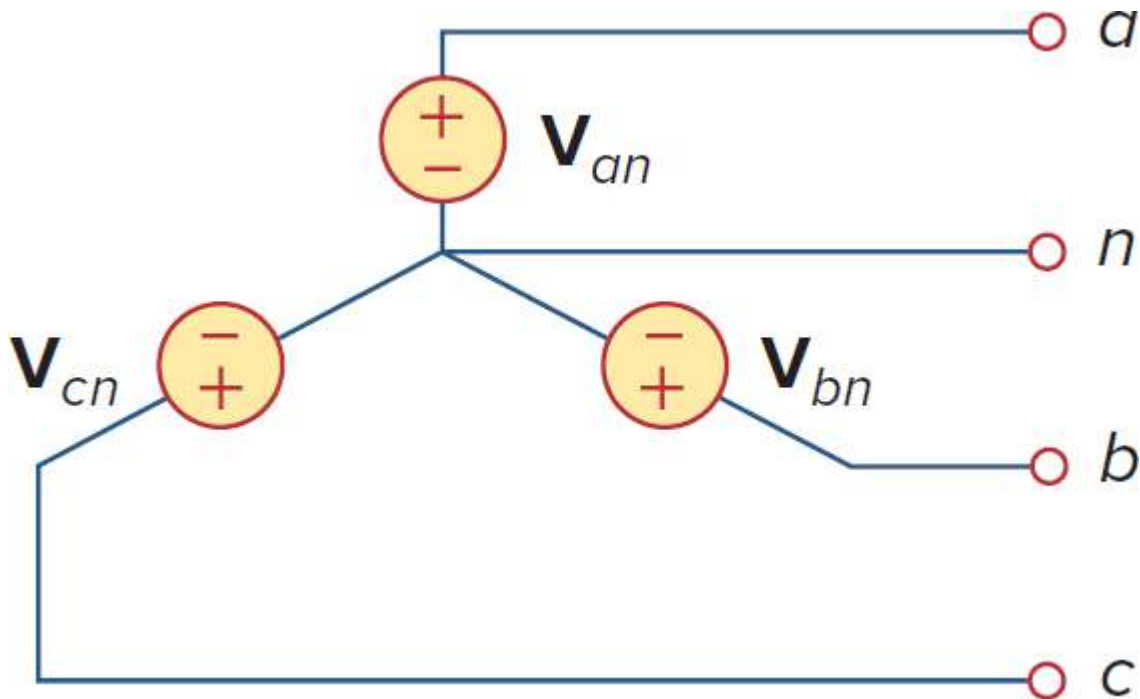

Y-connected source

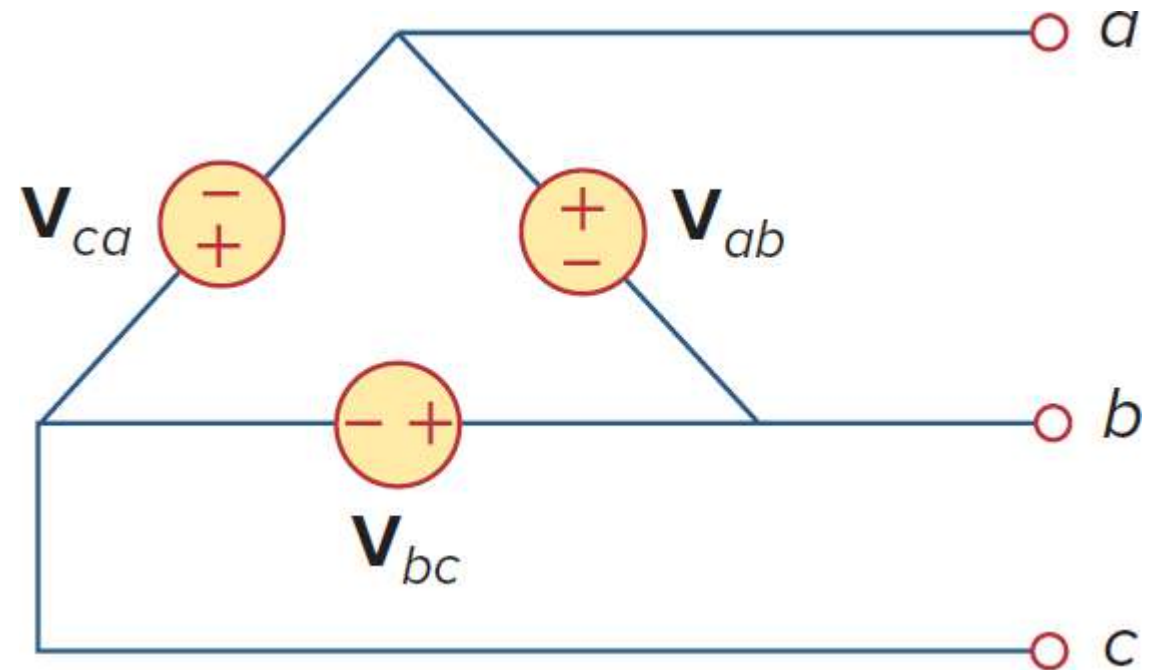

Δ-connected source

# THREE-PHASE LOADS

- 3-phase loads can also be either wye-connected or delta-connected.

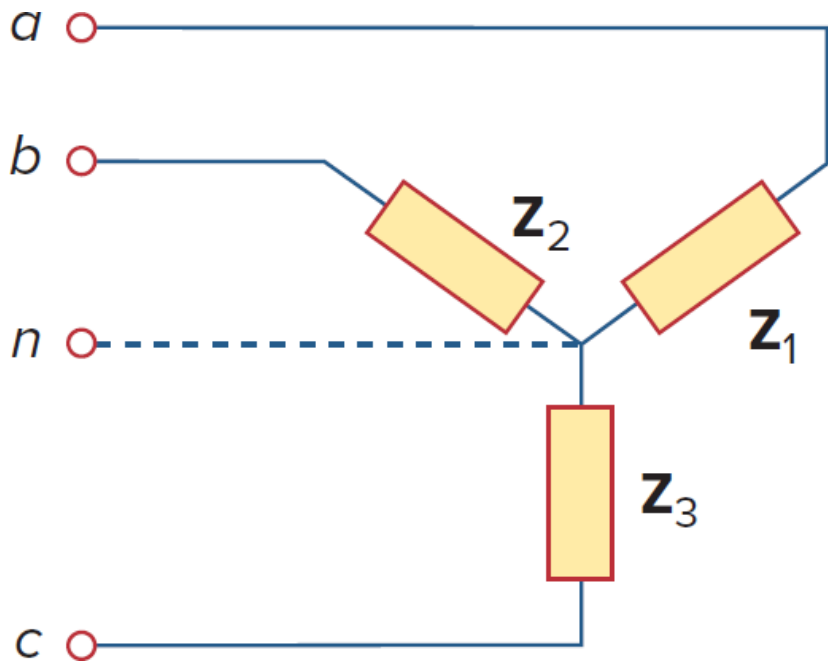

Y-connected load

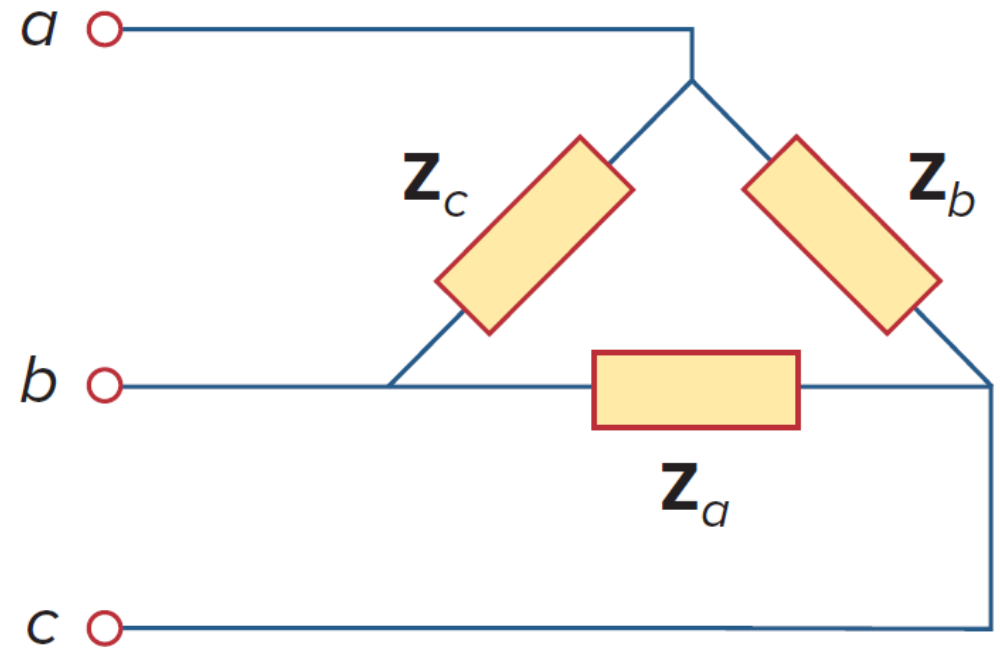

Δ-connected source

# BALANCED SOURCE AND LOAD

Balanced Source: All phase voltages are equal in magnitude and are out of phase with each other by  $120^\circ$ .

$$V_{an} = V_p \angle 0^\circ$$

$$V_{bn} = V_p \angle -120^\circ$$

$$V_{cn} = V_p \angle -240^\circ = V_p \angle +120^\circ$$

*abc* or positive sequence

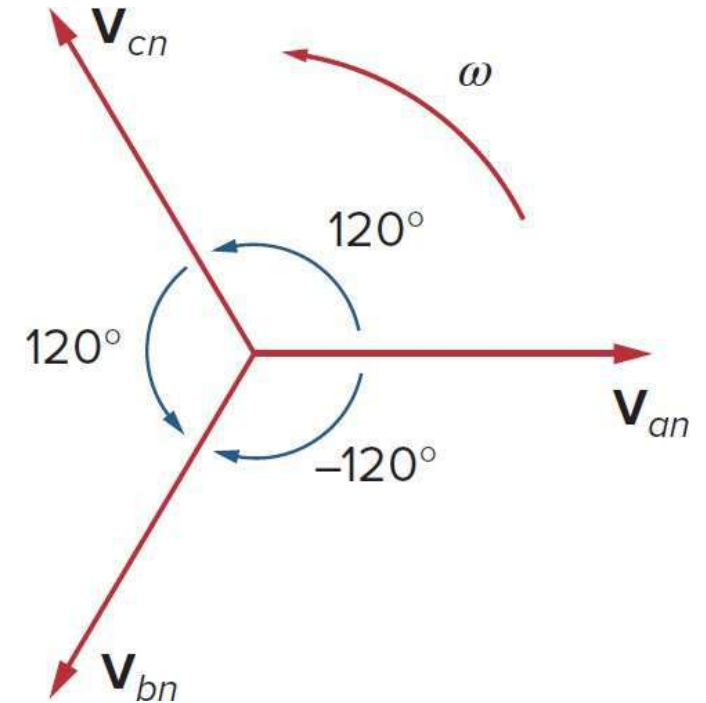

**Balanced Load:** The phase impedances are equal in magnitude and in phase.

# THREE PHASE QUANTITIES

<b>QUANTITY</b>	<b>SYMBOL</b>
Phase current	$I_p$
Line current	$I_L$
Phase voltage	$V_p$
Line voltage	$V_L$

# PHASE VOLTAGES & LINE VOLTAGES

Phase voltage is measured across any single source or load.

Line voltage is measured between any two of the three lines.

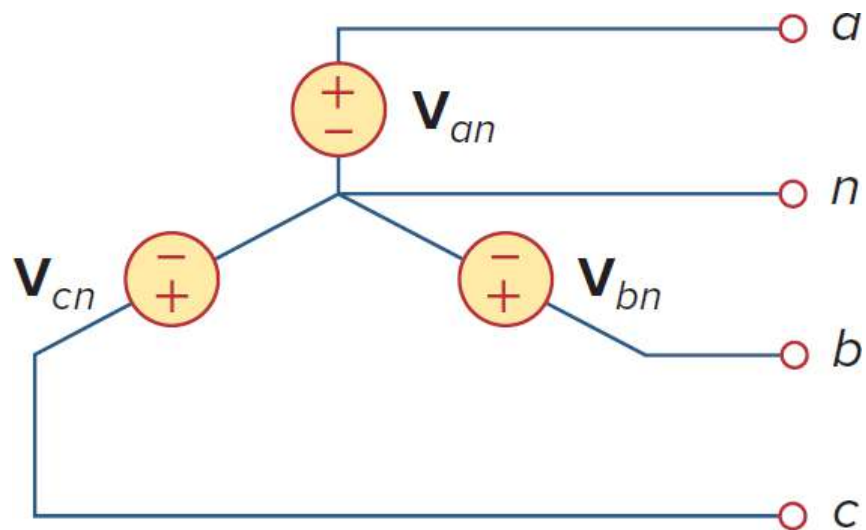

$$V_L = V_{ab} = V_{an} - V_{bn}$$

For balanced source,

$$V_L = V_p \angle 0^\circ - V_p \angle -120^\circ = \sqrt{3} V_p \angle 30^\circ$$

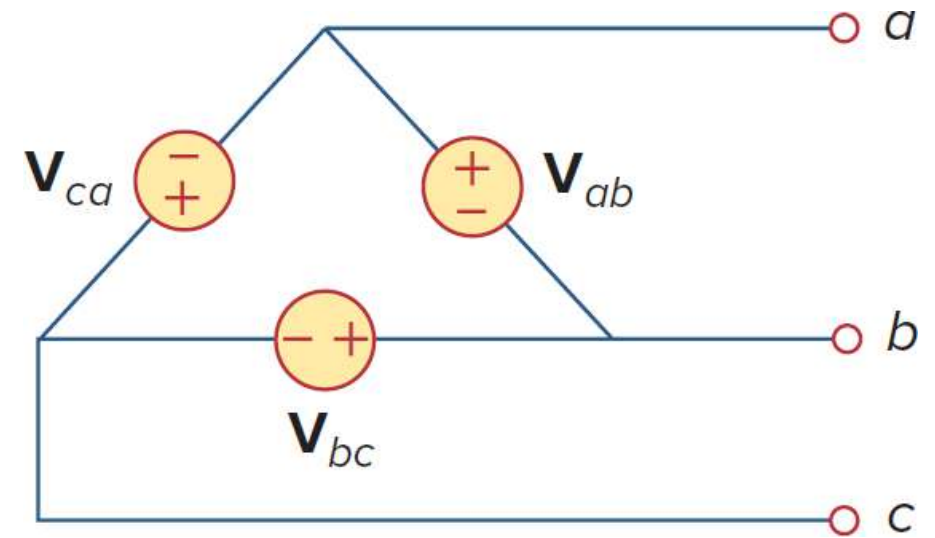

$$V_L = V_{ab} = V_p$$

# PHASE CURRENTS & LINE CURRENTS

Line current ( $I_L$ ) is the current in a *line* of the 3-phase system.

Phase current ( $I_p$ ) is the current in a *phase/arm* of the source or load.

For **balanced 3-phase system**:

For Y-load,  $I_L = I_p$

For  $\Delta$ -load,

$$I_L = I_a = I_{AB} - I_{CA}$$
$$= I_{AB} (1 - 1 \angle -240^\circ)$$

$$I_L = \sqrt{3} I_p \angle -30^\circ$$

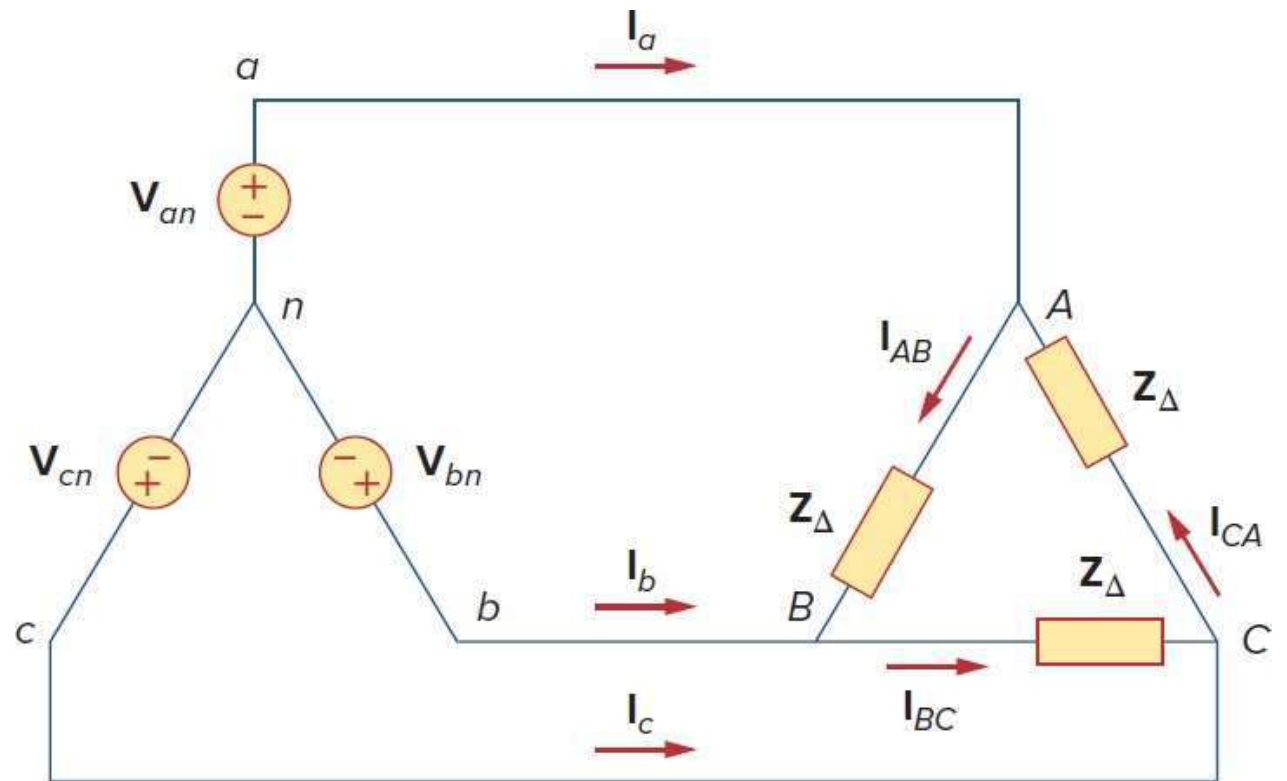

# Numerical 1

Calculate the line currents.

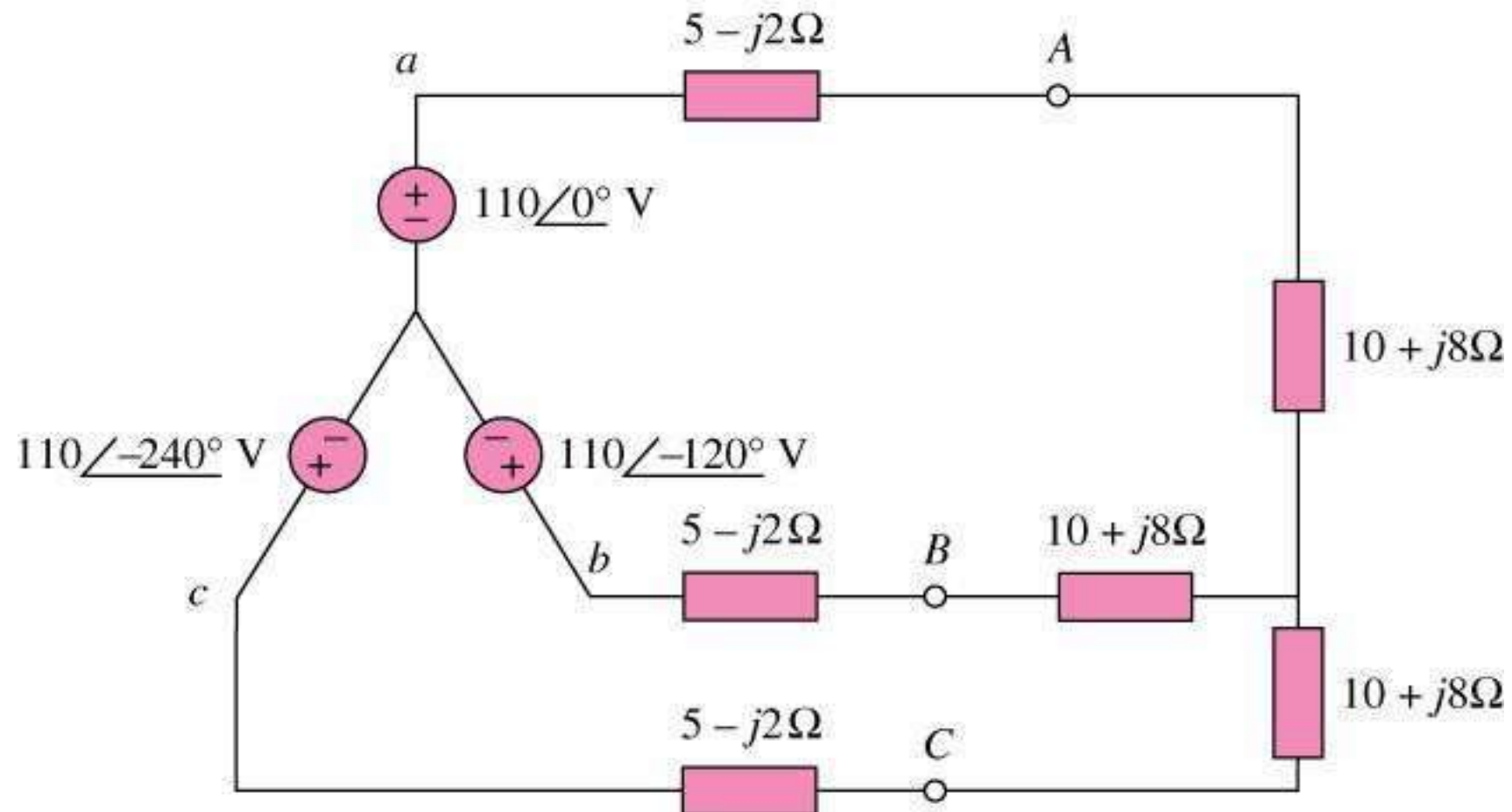

# Single Phase Equivalent Circuit

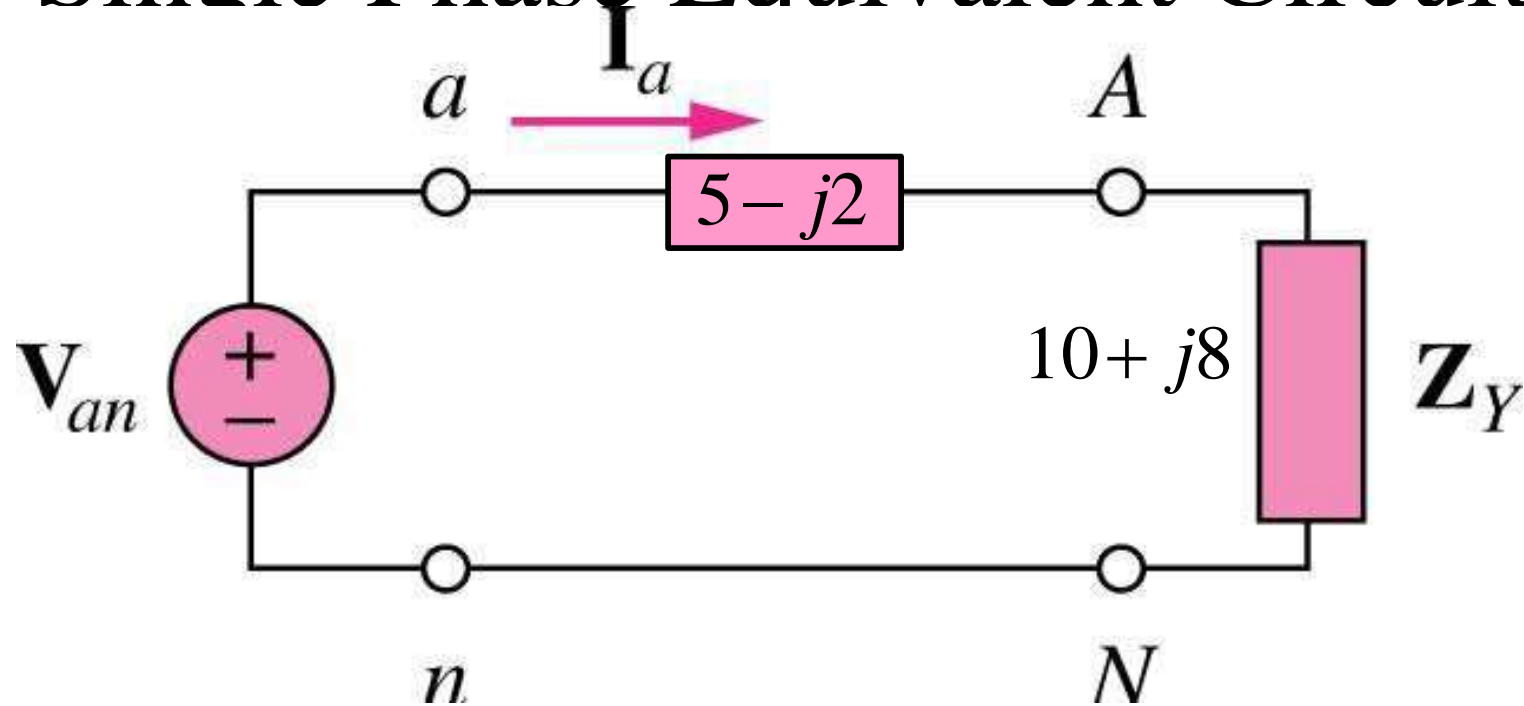

Total impedance per phase  $Z_Y = 15 + j6 = 16.155 \angle 21.8^\circ$

$$I_a = \frac{V_{an}}{Z_Y} = \frac{110 \angle 0^\circ}{16.155 \angle 21.8^\circ} = 6.81 \angle -21.8^\circ$$

$$I_b = I_a \angle -120^\circ \\ = 6.81 \angle -141.8^\circ \text{ A}$$

$$I_c = I_a \angle -240^\circ \\ = 6.81 \angle -261.8^\circ = 6.81 \angle 98.2^\circ \text{ A}$$

## Numerical 2

A balanced delta-connected load having an impedance  $20-j15 \Omega$  is connected to a delta-connected, positive-sequence generator having  $V_{ab} = 330 \angle 0^\circ \text{ V}$ .

Calculate the phase currents of the load and the line currents.

## Numerical 2

**Solution:**  $Z_{\Delta} = 20 - j15 \Omega = 25 \angle -36.87^{\circ}$

$$V_{ab} = 330 \angle 0^{\circ}$$

Phase Currents:  $I_{AB} = \frac{V_{AB}}{Z_{\Delta}} = \frac{330 \angle 0^{\circ}}{25 \angle -36.87^{\circ}} = 13.2 \angle 36.87^{\circ} \text{ A}$

$$I_{BC} = I_{AB} \angle -120^{\circ} = 13.2 \angle -83.13^{\circ} \text{ A}$$

$$I_{CA} = I_{AB} \angle +120^{\circ} = 13.2 \angle 156.87^{\circ} \text{ A}$$

Line Currents:

$$\begin{aligned} I_a &= I_{AB} \sqrt{3} \angle -30^\circ \\ &= (13.2 \angle 36.87^\circ) (\sqrt{3} \angle -30^\circ) \text{ A} \\ &= 22.86 \angle 6.87^\circ \end{aligned}$$

$$I_b = I_a \angle -120^\circ = 22.86 \angle -113.13^\circ \text{ A}$$

$$I_c = I_a \angle +120^\circ = 22.86 \angle 126.87^\circ \text{ A}$$

## Numerical 3

A balanced positive sequence Y-connected source with  $V_{an} = 100\angle 10^\circ$  V is connected to a  $\Delta$ -connected balanced load with impedance  $(8 + j4)$   $\Omega$  per phase.

Calculate the phase and line currents at the load.

**Solution:** Balanced Y-source with  $V_{an} = 100 \angle 10^\circ \text{ V}$   
Balanced  $\Delta$ -load with  $Z_{\Delta} = 8 + j4 \ \Omega$

Phase Current  $I_{AB} = \frac{V_{AB}}{Z_{\Delta}}$

Line Voltage  $V_{AB} = \sqrt{3} V_{an} \angle 30^\circ$

$$V_{AB} = 173.2 \angle 40^\circ \text{ V}$$

$$\Rightarrow I_{AB} = \frac{173.2 \angle 40^\circ}{8 + j4} = 19.36 \angle 13.43^\circ$$

Phase Currents:

$$I_{AB} = 19.36 \angle 13.43^\circ \quad A$$

$$I_{BC} = I_{AB} \angle -120^\circ = 19.36 \angle -106.57^\circ \quad A$$

$$I_{CA} = I_{AB} \angle +120^\circ = 19.36 \angle 133.43^\circ \quad A$$

Line Currents:

$$I_a = \sqrt{3} I_{AB} \angle -30^\circ = \sqrt{3} (19.36) \angle (13.43^\circ - 30^\circ)$$

$$I_a = 33.53 \angle -16.57^\circ \text{ A}$$

$$I_b = I_a \angle -120^\circ = 33.53 \angle -136.57^\circ \text{ A}$$

$$I_c = I_a \angle +120^\circ = 33.53 \angle 103.43^\circ \text{ A}$$

The phase voltage for each phase in a 3-phase system is given as

$$v_{AN} = \sqrt{2}V_p \cos \omega t$$

$$v_{BN} = \sqrt{2}V_p \cos(\omega t - 120^\circ)$$

$$v_{CN} = \sqrt{2}V_p \cos(\omega t + 120^\circ)$$

The phase currents are given as,

$$i_a = \sqrt{2}I_p \cos(\omega t - \theta)$$

$$i_b = \sqrt{2}I_p \cos(\omega t - \theta - 120^\circ)$$

$$i_c = \sqrt{2}I_p \cos(\omega t - \theta + 120^\circ)$$

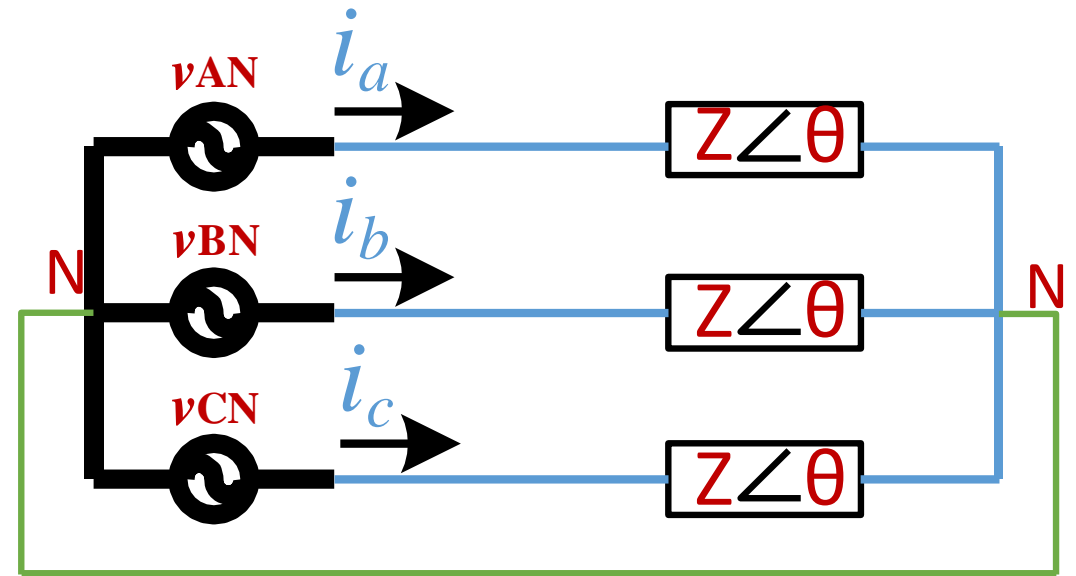

➤ The total instantaneous power is  $p = p_a + p_b + p_c = v_{AN}i_a + v_{BN}i_b + v_{CN}i_c$

$$p = 2V_p I_p \left[ \cos \omega t \cos(\omega t - \theta) + \cos(\omega t - 120) \cos(\omega t - \theta - 120) + \cos(\omega t + 120) \cos(\omega t - \theta + 120) \right]$$

➤ Applying the trigonometric identity  $\cos A \cos B = \frac{1}{2} [\cos(A + B) + \cos(A - B)]$

$$p = V_p I_p \left[ 3 \cos \theta + \cos(2\omega t - \theta) + \cos(2\omega t - \theta - 240) + \cos(2\omega t - \theta + 240) \right]$$

$$p = V_p I_p \left[ 3 \cos \theta + \cos \alpha + \cos \alpha \cos 240 + \sin \alpha \sin 240 + \cos \alpha \cos 240 - \sin \alpha \sin 240 \right]$$

where,  $\alpha = 2\omega t - \theta$

$$p = V_p I_p \left[ 3 \cos \theta + \cos \alpha + 2 \left( -\frac{1}{2} \right) \cos \alpha \right] = 3V_p I_p \cos \theta$$

**The total instantaneous power in a balanced three-phase system is constant! Even though the instantaneous power of each phase is time-varying. This result is true whether the load is Y- or  $\Delta$ - connected.**

**The average power per phase  $P_p$  for either the  $\Delta$ -connected or the Y-connected balanced load is  $P/3$ , or**

$$P_p = V_p I_p \cos \theta$$

And the reactive power per phase is

$$Q_p = V_p I_p \sin \theta$$

The apparant power per phase is

$$S_p = V_p I_p$$

The complex power per phase is

$$S_p = P_p + jQ_p = \mathbf{V}_p \mathbf{I}_p^*$$

Here  $V_p$  and  $I_p$  are rms values of the phase voltage and phase current .

- The total average power is the sum of the average powers in the phases:

$$P = P_a + P_b + P_c = 3P_p = 3V_p I_p \cos \theta = \sqrt{3}V_L I_L \cos \theta$$

- For a Y-connected load,  $I_L = I_p$  and  $V_L = \sqrt{3}V_p$

- For a  $\Delta$ -connected load,  $I_L = \sqrt{3}I_p$  and  $V_L = V_p$

- Similarly, the total reactive power is  $Q = 3V_p I_p \sin \theta = \sqrt{3}V_L I_L \sin \theta$

- The total complex power:  $S = 3S_p = 3\mathbf{V}_p \mathbf{I}_p^* = 3I_p^2 \mathbf{Z}_p = \frac{3V_p^2}{\mathbf{Z}_p^*}$

$\mathbf{Z}_p = Z_p \angle \theta$  is the load impedance per phase

$$S = P + jQ = \sqrt{3}V_L I_L \angle \theta$$

- $V_p$ ,  $I_p$ ,  $V_L$ , and  $I_L$  are all rms values and that  $\theta$  is the angle of the load impedance or the angle between the phase voltage and the phase current.

## Line Power Quantities for Balanced Y- or $\Delta$ -loads

- Instantaneous power:  $p(t) = p_a(t) + p_b(t) + p_c(t) = 3 V_p I_p \cos(\varphi)$
- Real Power:  $P = \sqrt{3} V_L I_L \cos \varphi$
- Reactive Power:  $Q = \sqrt{3} V_L I_L \sin \varphi$
- Apparent Power:  $S = \sqrt{3} V_L I_L$
- NOTE:  $\varphi$  is the load (or impedance) angle i.e. the angle between the phase voltage and phase current.

Check that power remains same on Y- $\Delta$  transformation

# Numerical 4

For the balanced system shown in figure, find:

- The magnitude of the line current
- The magnitude of the line and phase voltages at the load
- The real, reactive and apparent powers consumed by the load
- The power factor of the load.

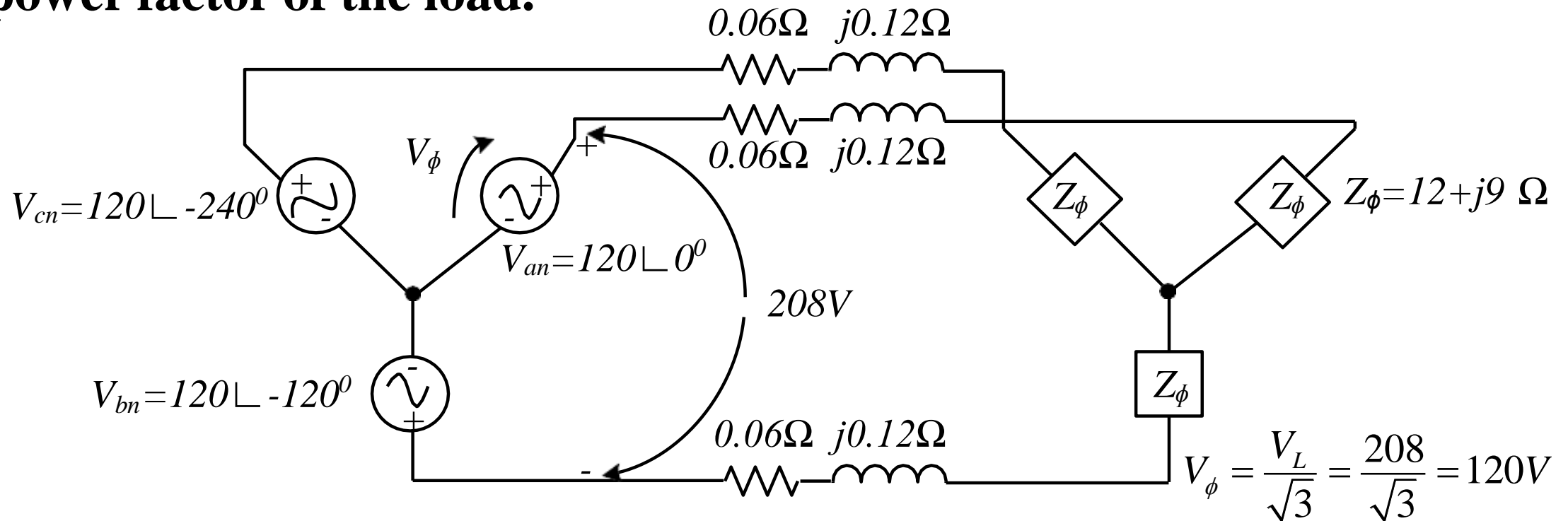

## Solution:

Both, the generator and the load are Y-connected, therefore, its easy to construct a per phase equivalent circuit.

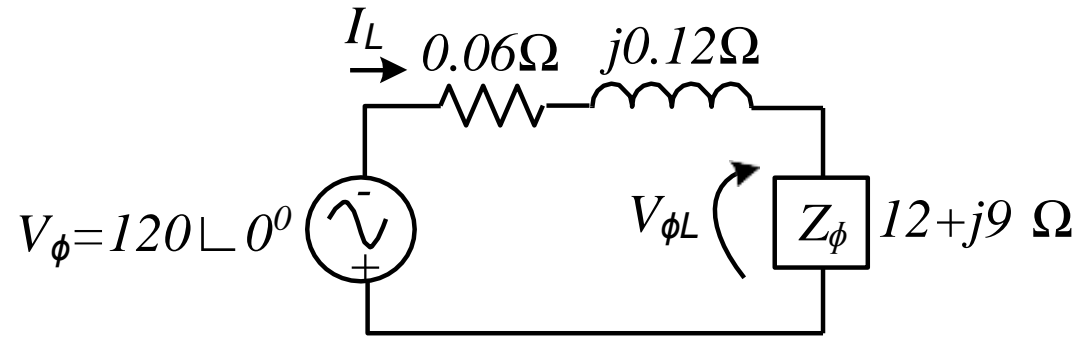

a) Phase/line current:

$$I_L = \frac{V}{Z_L + Z_{load}} = \frac{120 \angle 0^{\circ}}{(0.06 + j0.12) + (12 + j9)} = \frac{120 \angle 0^{\circ}}{15.12 \angle 37.1^{\circ}} = 7.94 \angle -37.1^{\circ} \text{ A}$$

b) Phase voltage over the load:  $V_p = I_p * Z_p = (7.94 \angle -37.1^{\circ})(12 + j9) = 119.1 \angle -0.2^{\circ} \text{ V}$

The magnitude of the line voltage on the load:  $V_L = \sqrt{3} V_p = 206.3 \text{ V}$

c) The real power consumed by the load:

$$P_{load} = 3V_p I_p \cos \varphi = 3 \times 119.1 \times 7.94 \cos 36.9^\circ = 2270 \text{ W}$$

The reactive power consumed by the load:

$$Q_{load} = 3V_p I_p \sin \varphi = 3 \times 119.1 \times 7.94 \sin 36.9^\circ = 1702 \text{ var}$$

The apparent power consumed by the load:

$$S_{load} = 3V_p I_p = 3 \times 119.1 \times 7.94 = 2839 \text{ VA}$$

d) The load power factor:

$$\text{Pf}_{load} = \cos \Phi = \cos 36.9^\circ = 0.8 \text{ lagging}$$

# Advantage of Three Phase System

- A major advantage of **three-phase systems** for power distribution is that the three-phase system uses a **lesser amount of wire than the single-phase system** for the same line voltage  $V_L$  and the **same absorbed load power  $P_L$** .
- The two cases (of single phase and three phase system) will be compared in the next slides, considering that **both have wires of the same material and length**, and that the **loads are resistive**.

# Power Loss in Single Phase and Three Phase Systems

For the two-wire single-phase system,  $I_L = \frac{P_L}{V_L}$ , so the total power loss in the two transmission wires is

$$P_{loss} = 2I_L^2 R = 2R \frac{P_L^2}{V_L^2} \quad (1)$$

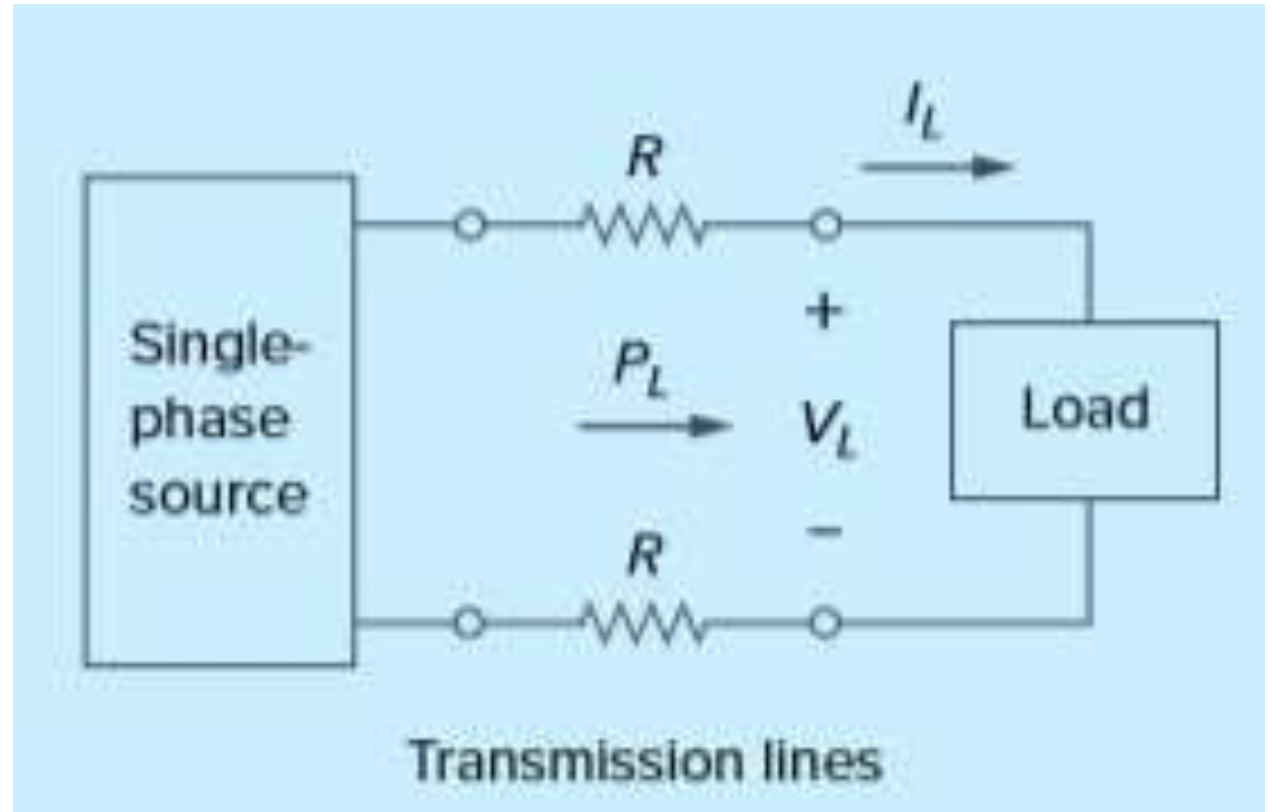

For the three-wire, three-phase system,  $I_L' = |I_a| = |I_b| = |I_c| = P_L / \sqrt{3}V_L$   
 The total power loss in the three transmission wires is

$$P'_{loss} = 3(I_L')^2 R' = 3R' \left( \frac{P_L^2}{3V_L^2} \right) = R' \left( \frac{P_L^2}{V_L^2} \right) \quad (2)$$

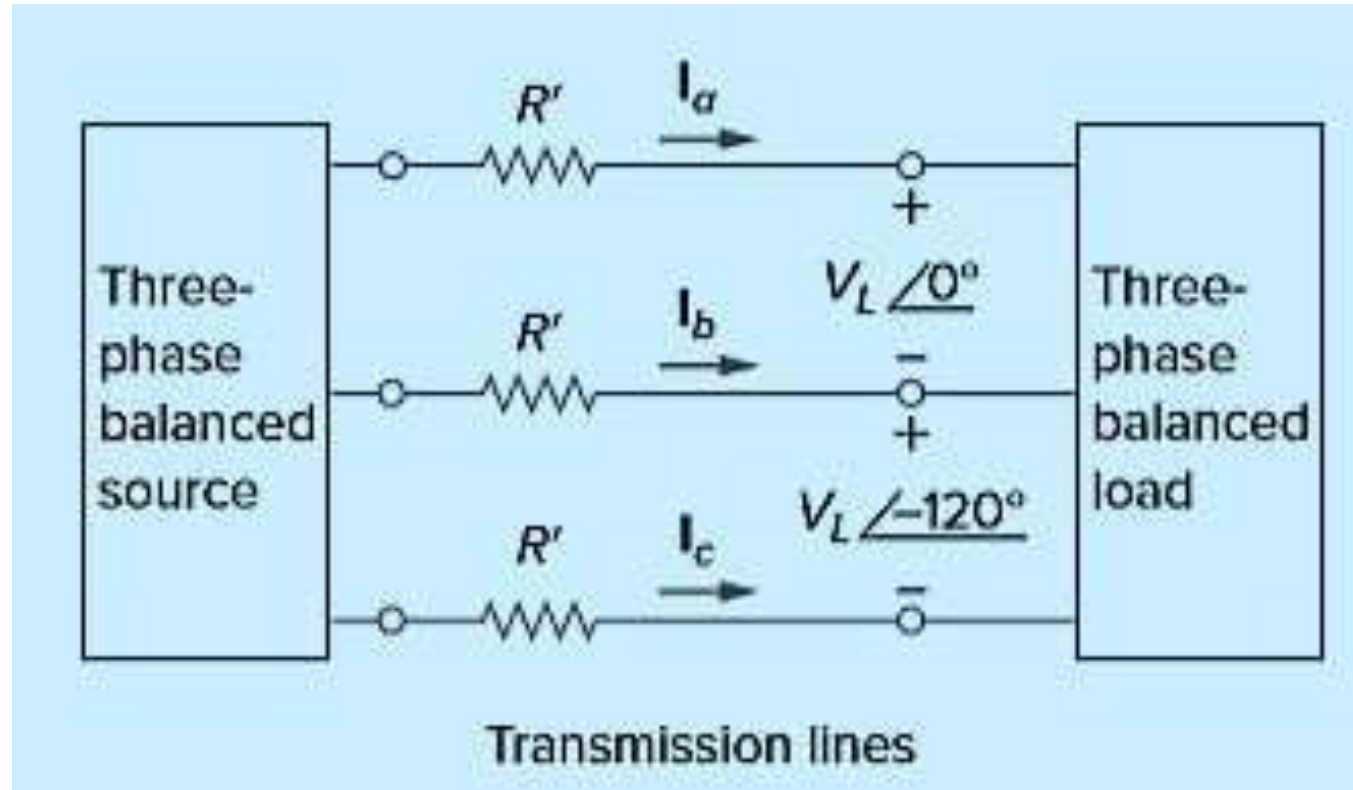

Equations (1) and (2) show that for the same total power delivered  $P_L$  and same line voltage  $V_L$ ,

$$\frac{P_{loss}}{P'_{loss}} = \frac{2R}{R'} \quad (3)$$

Also  $R = \frac{\rho l}{\pi r^2}$  and  $R' = \frac{\rho l}{\pi (r')^2}$  where  $r$  and  $r'$  are the radii of the wires

$$\Rightarrow \frac{P_{loss}}{P'_{loss}} = \frac{2(r')^2}{r^2} \quad (4)$$

If the same power loss is tolerated in both systems, then  $r^2 = 2(r')^2$ . The ratio of material required is determined by the number of wires and their volumes,

$$\frac{\text{Material for single phase}}{\text{Material for three phase}} = \frac{2(\pi r^2 l)}{3(\pi (r')^2 l)} = \frac{2r^2}{3(r')^2} = \frac{2}{3} (2) = 1.33$$

# UNBALANCED THREE PHASE SYSTEMS

- (1) The source voltages are not equal in magnitude and/or differ in phase by angles that are unequal, or
- (2) load impedances are unequal (more practical scenario).

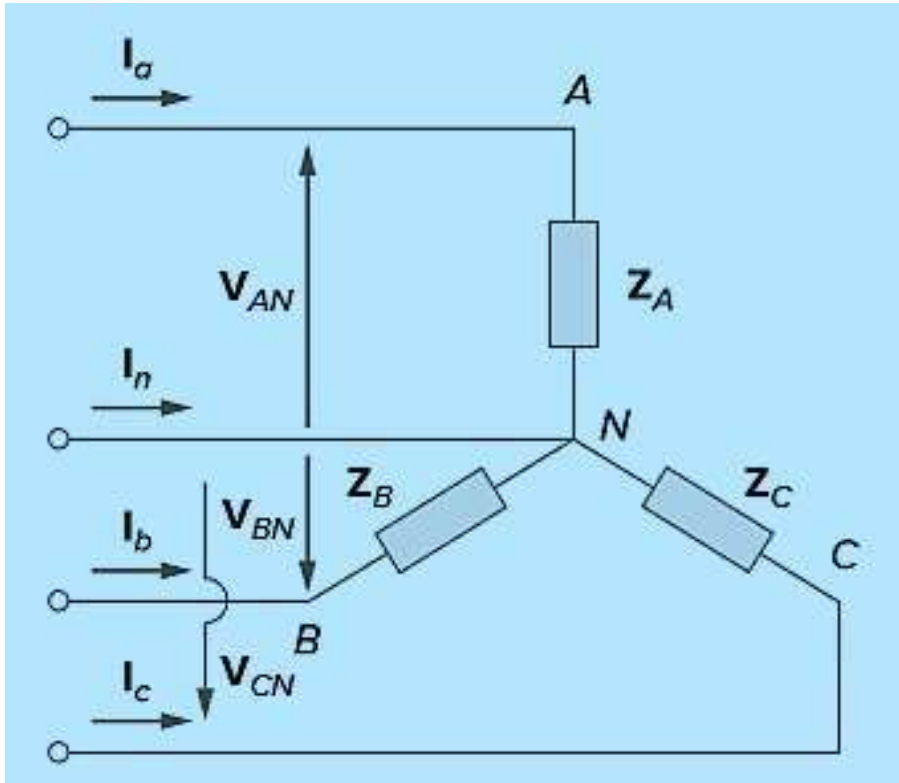

$$\mathbf{I}_a = \frac{\mathbf{V}_{AN}}{\mathbf{Z}_A}, \quad \mathbf{I}_b = \frac{\mathbf{V}_{BN}}{\mathbf{Z}_B}, \quad \mathbf{I}_c = \frac{\mathbf{V}_{CN}}{\mathbf{Z}_C}$$

$$I_n = -(I_a + I_b + I_c)$$

- In a **three-wire system** where the **neutral line is absent**, we can still find the line currents  $I_a$ ,  $I_b$ , and  $I_c$  using mesh analysis.
- At node  $N$ , KCL must be satisfied so that  $I_a + I_b + I_c = 0$  in this case. **The voltage at node  $N$  will not be zero** in such a case. The same could be done for an unbalanced  $\Delta$ -Y, Y- $\Delta$ , or  $\Delta$ - $\Delta$  three-wire system.
- To calculate power in an unbalanced three-phase system requires that we find the power in each phase earlier.
- The **total power** is not simply three times the power in one phase but **the sum of the powers in the three phases**.

## THREE-PHASE POWER MEASUREMENT

- A **single wattmeter** can measure the average power in a three-phase system that is **balanced** i.e.  $P_1 = P_2 = P_3$ ; the total power is just 3x the reading of that one wattmeter.
- However, **two or three single-phase wattmeters** are necessary to measure power if the system is **unbalanced**.

# THREE-WATTMETER METHOD

This method can work regardless of whether the load is balanced or unbalanced, wye- or delta-connected.  $P_T = P_1 + P_2 + P_3$

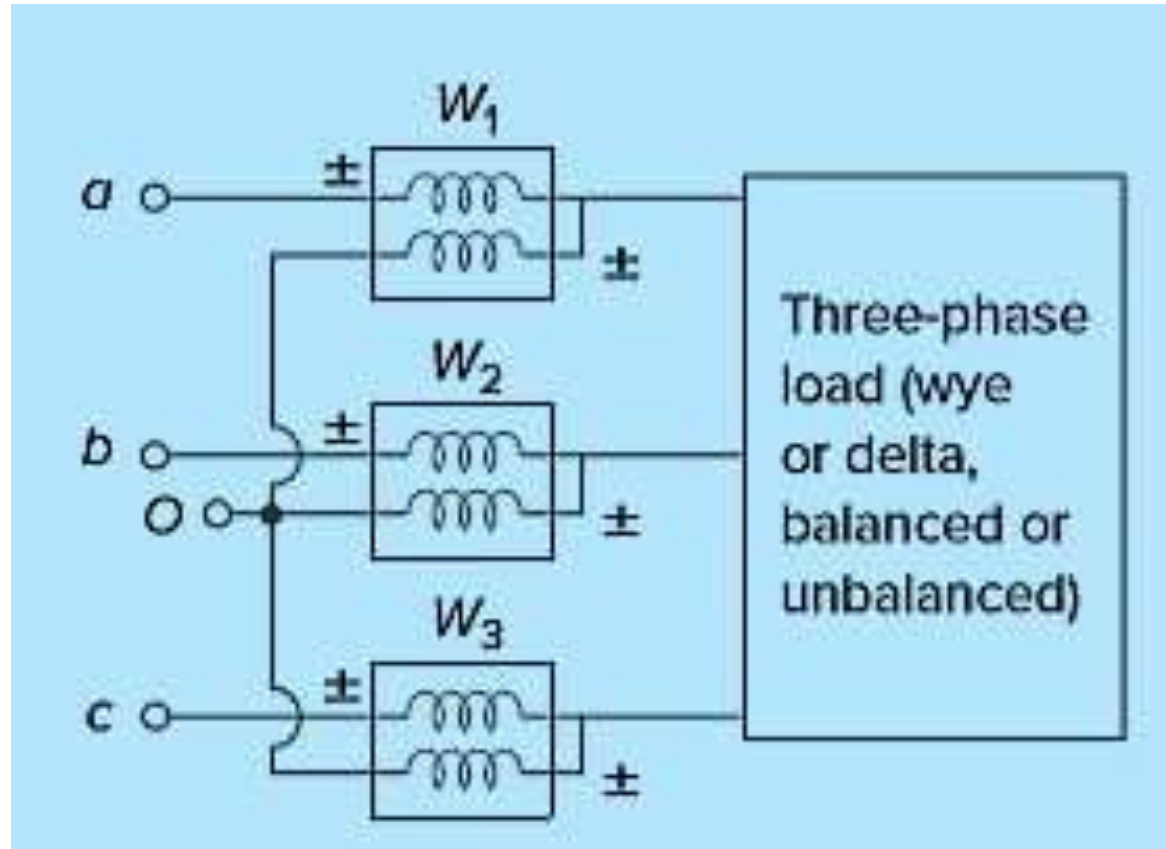

# TWO-WATTMETER METHOD

The two-wattmeter method is the most commonly used method for three-phase power measurement in a 3-wire system (no neutral wire).

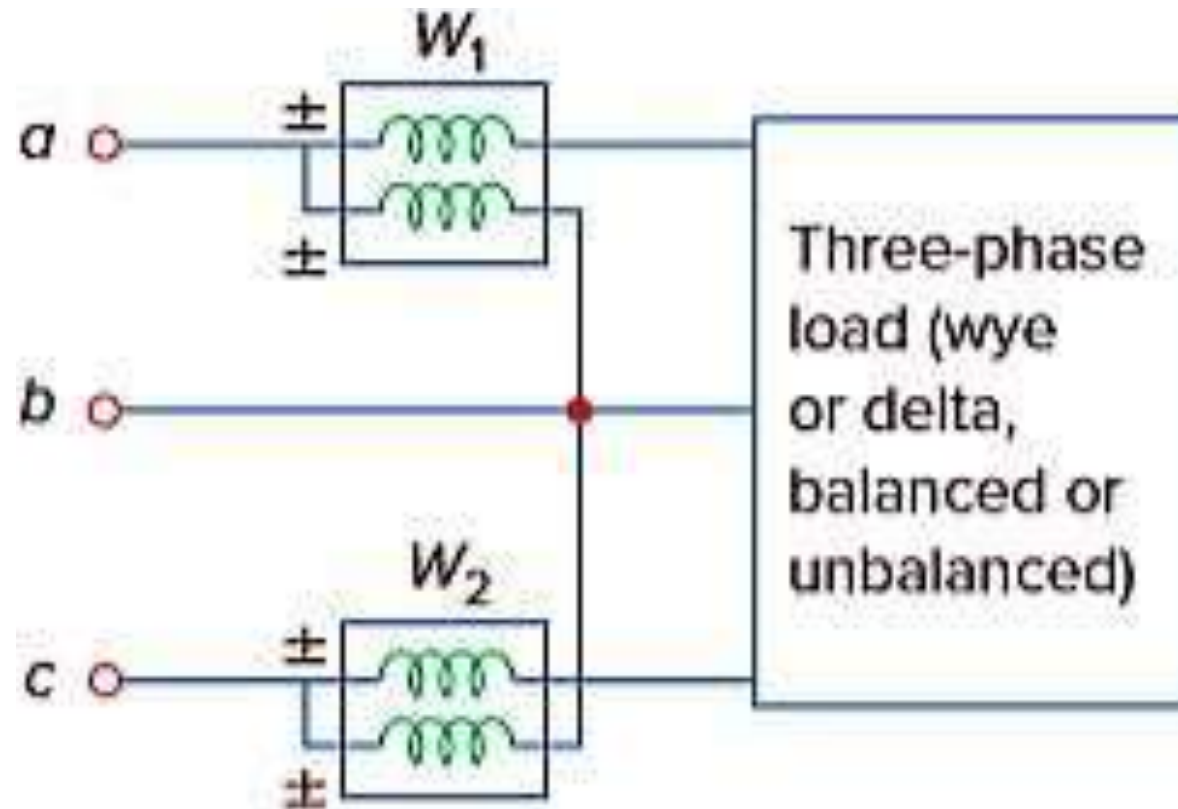

- Notice that the **current coil** of **each wattmeter** measures the **line current**, while the respective **voltage coil** is connected between the respective line and the third line and measures the **line voltage**.
- Although the individual wattmeters no longer read the power taken by any particular phase, the algebraic sum of the two wattmeter readings equals the total average power absorbed by the load, regardless of whether it is wye- or delta-connected, balanced or unbalanced.
- The **total real power** is equal to the **algebraic sum** of the two **wattmeter readings**

$$P_T = P_1 + P_2$$

## Two-Wattmeter Method for a balanced three phase system

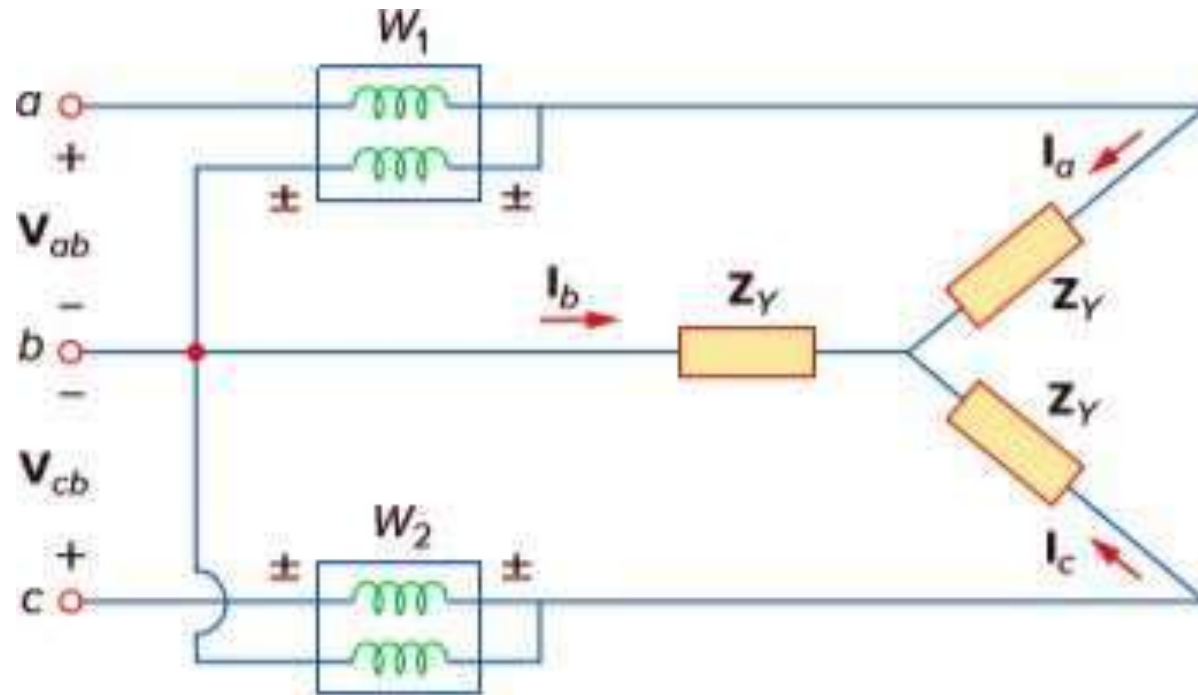

Assume the source is in the *abc* sequence and the load impedance  $\mathbf{Z}_y = Z_y \angle \theta$ .

Each phase voltage leads its respective phase current by  $\theta$

Each line voltage leads the corresponding phase voltage by  $30^\circ$ .

- Thus, the total phase difference between the phase current  $I_a$  and line voltage  $V_{ab}$  is  $\theta + 30^\circ$ .
- The average power read by wattmeter  $W_1$  is

$$P_1 = \text{Re}(\mathbf{V}_{ab} \mathbf{I}_a^*) = V_{ab} I_a \cos(\theta + 30^\circ) = V_L I_L \cos(\theta + 30^\circ)$$

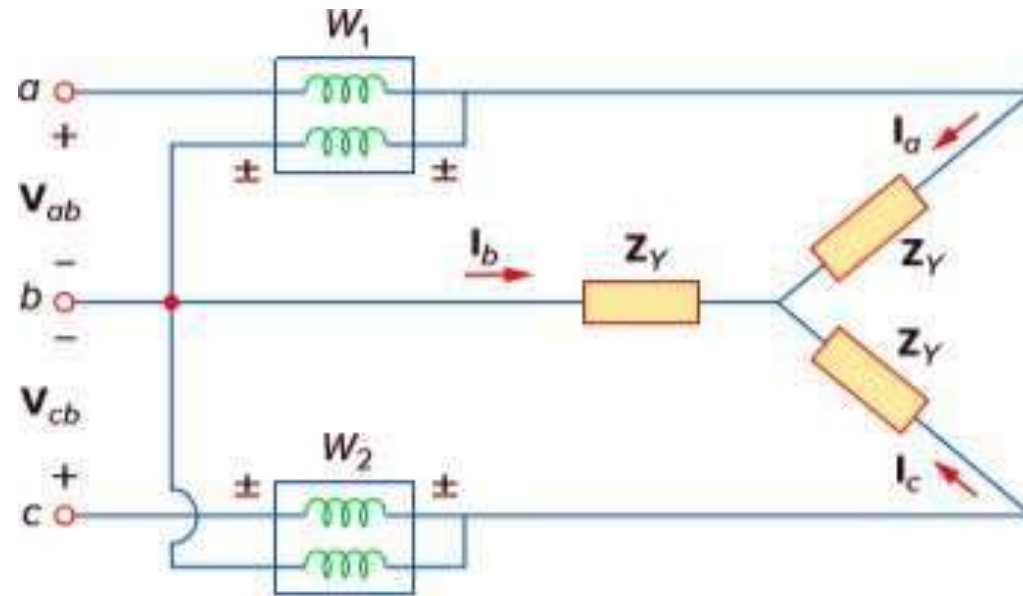

- Similarly, we can show that the average power read by wattmeter 2 is
- $$P_2 = \text{Re}(\mathbf{V}_{cb} \mathbf{I}_c^*) = V_{cb} I_c \cos(\theta - 30^\circ) = V_L I_L \cos(\theta - 30^\circ)$$

We now use the trigonometric identities  $\cos(A + B) = \cos A \cos B - \sin A \sin B$   
 $\cos(A - B) = \cos A \cos B + \sin A \sin B$   
to find the sum and the difference of the two wattmeter reading  $P_1$  and  $P_2$

$$P_1 + P_2 = V_L I_L \left[ \cos(\theta + 30^\circ) + \cos(\theta - 30^\circ) \right]$$

$$P_1 + P_2 = V_L I_L \left[ \cos \theta \cos 30 - \sin \theta \sin 30 + \cos \theta \cos 30 + \sin \theta \sin 30 \right]$$

$$P_1 + P_2 = V_L I_L 2 \cos \theta \cos 30 = \sqrt{3} V_L I_L \cos \theta$$

Thus, the sum of the wattmeter readings gives the total average power

$$P_T = P_1 + P_2 \quad (1)$$

$$\text{Similarly } P_1 - P_2 = V_L I_L \left[ \cos(\theta + 30^\circ) - \cos(\theta - 30^\circ) \right]$$

$$P_1 - P_2 = V_L I_L \left[ \cos \theta \cos 30 - \sin \theta \sin 30 - \cos \theta \cos 30 - \sin \theta \sin 30 \right]$$

$$P_1 - P_2 = -V_L I_L 2 \sin \theta \sin 30$$

$$P_2 - P_1 = V_L I_L \sin \theta$$

Thus, the difference of the wattmeter readings is proportional to the total reactive power,

$$Q_T = \sqrt{3} (P_2 - P_1) \quad (2)$$

➤ From (1) and (2), the apparent power can be calculated as  $S_T = \sqrt{P_T^2 + Q_T^2}$

➤ Dividing Eq. (2) by Eq. (1) gives the tangent of the power factor angle as

$$\tan \theta = \frac{Q_T}{P_T} = \sqrt{3} \left( \frac{P_2 - P_1}{P_2 + P_1} \right)$$

➤ Thus the power factor is,

$$\cos \theta = \cos \left( \tan^{-1} \sqrt{3} \left( \frac{P_2 - P_1}{P_2 + P_1} \right) \right)$$

Thus, the two-wattmeter method not only provides the total real and reactive powers, it can also be used to compute the power factor.

**1. If  $P_2 = P_1$ , the load is resistive.**

**2. If  $P_2 > P_1$ , the load is inductive.**

**3. If  $P_2 < P_1$ , the load is capacitive.**

- Although these results are derived from a balanced Y-connected load, they are equally valid for a balanced  $\Delta$ -connected load.
- The two-wattmeter method cannot be used for power measurement in a 3-phase 4-wire system unless the current through the neutral line is zero.
- We can use the three-wattmeter method to measure the real power in a 3-phase 4-wire system.

# Numerical

5

The three-phase balanced load in figure, has impedance per phase of  $Z_Y = 8 + j6 \Omega$ . If the load is connected to 208-V lines, predict the readings of the wattmeter  $W_1$  and  $W_2$ . Find  $P_T$  and  $Q_T$ .

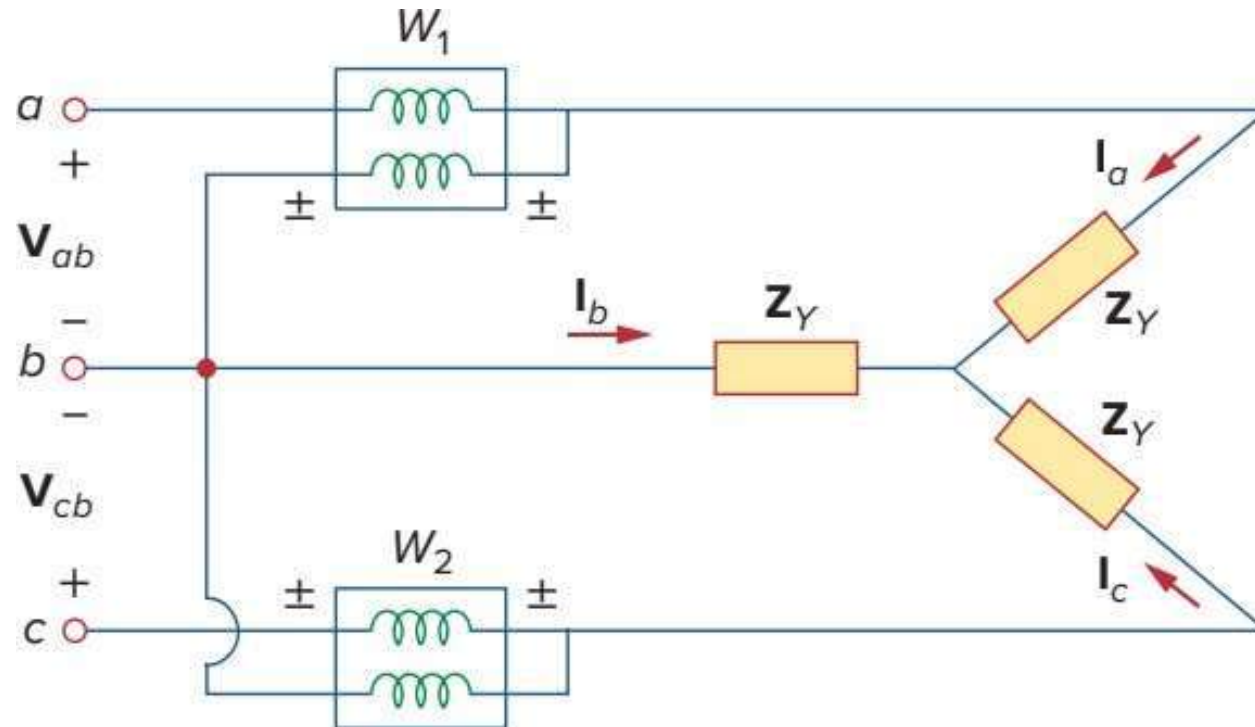

# Numerical

5

## Solution:

The impedance per phase is  $Z_Y = (8 + j6) = 10 \angle 36.87^\circ$

Thus the Power Factor angle  $\theta = 36.87^\circ$ .

Since the line voltage  $V_L = 208 \text{ V}$ ,  
the line current is

$$I_L = \frac{V_p}{|Z_Y|} = \frac{208/\sqrt{3}}{10} = 12 \text{ A}$$

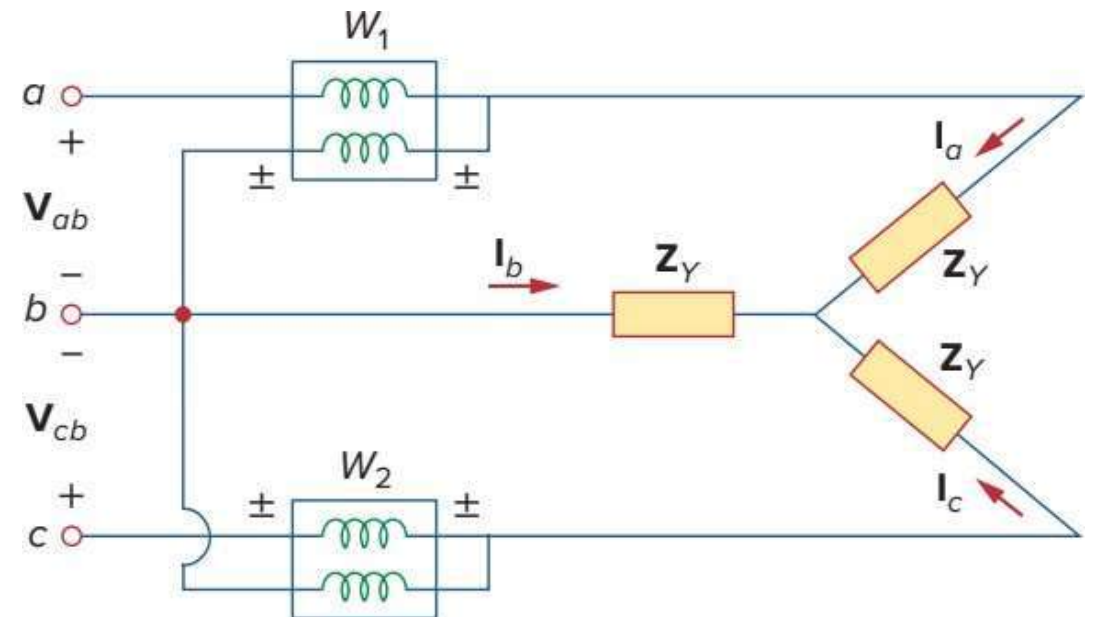

$$P_1 = V_L I_L \cos(\theta + 30^\circ) = 208 * 12 * \cos(36.87^\circ + 30^\circ) = 980.48 W$$

$$P_2 = V_L I_L \cos(\theta - 30^\circ) = 208 * 12 * \cos(36.87^\circ - 30^\circ) = 2478.1 W$$

Since  $P_2 > P_1$ , the load is inductive. This is evident from the load  $Z_Y$  itself.

$$P_T = P_1 + P_2 = 3.459 kW$$

$$Q_T = \sqrt{3}(P_2 - P_1) = \sqrt{3}(1497.6) VAR = 2.594 kVAR$$

# Numerical

Three wattmeters  $W_1$ ,  $W_2$ , and  $W_3$  are connected, respectively, to phases A, B, and C of an unbalanced Y-connected load as in figure. The balanced source is Y-connected with phase voltage 100 V in negative ( $acb$ ) sequence.

Find

- (a) the wattmeter readings
- (b) the total power absorbed by the load.

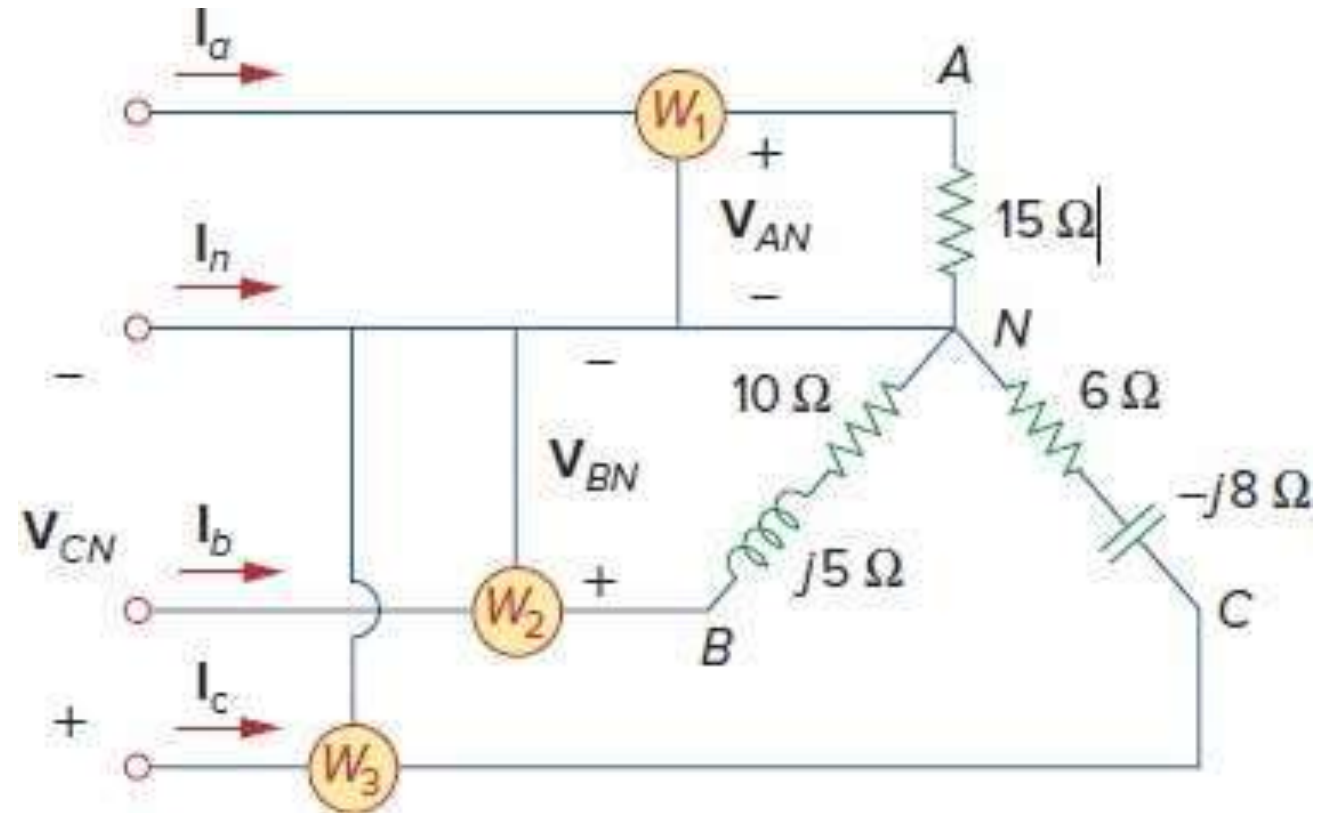

# Numerical

## 6

**Solution:** The line currents are,

$$I_a = \frac{100 \angle 0^\circ}{15} = 6.67 \angle 0^\circ \text{ A}$$

$$I_b = \frac{100 \angle 120^\circ}{10 + j5} = 8.94 \angle 93.44^\circ \text{ A}$$

$$I_c = \frac{100 \angle -120^\circ}{6 - j8} = 10 \angle -66.87^\circ \text{ A}$$

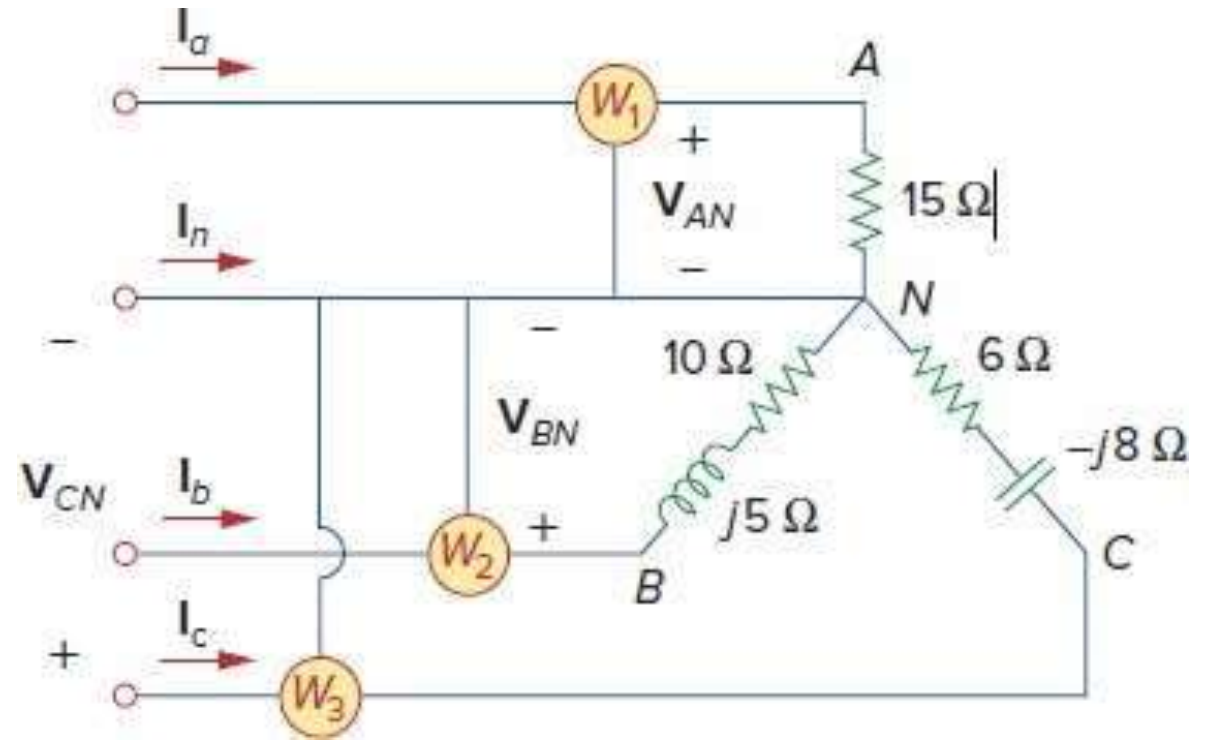

(a) The wattmeter readings are,

$$P_1 = \operatorname{Re}(V_{AN} I_a^*) = V_{AN} I_a \cos(\theta_{V_{AN}} - \theta_{I_a}) = 100 * 6.67 * \cos(0^\circ - 0^\circ) = 667 \text{ W}$$

$$P_2 = \operatorname{Re}(V_{BN} I_b^*) = V_{BN} I_b \cos(\theta_{V_{BN}} - \theta_{I_b}) = 100 * 8.94 * \cos(120^\circ - 93.44^\circ) = 800 \text{ W}$$

$$P_3 = \operatorname{Re}(V_{CN} I_c^*) = V_{CN} I_c \cos(\theta_{V_{CN}} - \theta_{I_c}) = 100 * 10 * \cos(-120^\circ + 66.87^\circ) = 600 \text{ W}$$

(b) The total power absorbed is  $P_T = P_1 + P_2 + P_3 = 667 + 800 + 600 = 2067 \text{ W}$

The power absorbed can also be calculated as the power dissipated across the resistors,

$$P_T = |I_a|^2 (15) + |I_b|^2 (10) + |I_c|^2 (6) = 6.67^2 (15) + 8.94^2 (10) + 10^2 (6) = 667 + 800 + 600 = 2067 \text{ W}$$

**The two-wattmeter method produces wattmeter readings  $P_1 = 1560 \text{ W}$  and  $P_2 = 2100 \text{ W}$  when connected to a delta-connected load. If the line voltage is  $220 \text{ V}$ , calculate:**

- (a) the per-phase average power,**
- (b) the per-phase reactive power,**
- (c) the power factor.**

**Solution:****Numerical 7**

(a). The total real or average power is  $P_T = P_1 + P_2 = 1560 + 2100 = 3660W$

The per phase average power is  $P_p = \frac{P_T}{3} = \frac{3660}{3} = 1220W$

(b) The total reactive power is  $Q_T = \sqrt{3}(P_2 - P_1) = \sqrt{3}(2100 - 1560) = 935.3VAR$

The per phase reactive power is  $Q_p = \frac{Q_T}{3} = \frac{935.3}{3} = 311.77VAR$

(c) The power-factor angle is  $\theta = \tan^{-1}\left(\frac{Q_T}{P_T}\right) = \tan^{-1}\left(\frac{935.3}{3660}\right) = 14.33^\circ$

Hence the power factor is  $\cos\theta = 0.9689$  (lagging) as  $Q_T$  is positive or  $P_2 > P_1$

# References

- Edward Hughes; John Hiley, Keith Brown, Ian McKenzie Smith, “Electrical and Electronic Technology”, 10th edition, Pearson Education Limited, 2008.
- Alexander, Charles K., and Sadiku, Matthew N. O., Fundamentals of Electric Circuits, 5th Ed, McGraw Hill, Indian Edition, 2013.