

**LAB DEMONSTRATION**  
**ON**  
**Energy conservation and Audit**  
**(20A02706)**

**IV B. Tech I Semester (R20)**

**Prepared by**

**Mr.M.Murali, M.Tech., (Ph.D)**  
**Associate Professor**



**DEPARTMENT OF ELECTRICAL AND ELECTRONICS ENGINEERING**

**VEMU INSTITUTE OF TECHNOLOGY**

**NEAR PAKALA, CHITTOOR-517112, A.P**

**(Approved by AICTE, New Delhi & Affiliated to JNTUA, Anantapuramu)**

**VEMU INSTITUTE OF TECHNOLOGY::P.KOTHAKOTA**

NEAR PAKALA, CHITTOOR-517112

(Approved by AICTE, New Delhi &amp; Affiliated to JNTUA, Anantapuramu)

**List of Experiments to be conducted****ENERGY CONSERVATION AND AUDIT LABORATORY(20A02706)**

S.NO.	NAME OF THE EXPERIMENT
1	Analyze star labeled electrical apparatus and compare the data sheet (Pamphlet) of various star ratings.
2	Determine the reduction in power consumption in star mode operation of Induction motor compared to delta mode at no load /light loads
3	Use APFC/PFC unit for improvement of p. f. of electrical load.
4	Compare power consumption of (Fluorescent and LED) lighting
5	Determine Net Energy Saving by Lamp replacements.
6	Determine Energy conservation in Fan by using Electronic Regulator
7	To analyze the energy bill of a commercial consumer and to suggest (if needed) suitable tariff to achieve energy conservation and reduction in energy bill
8	To interpret the energy bill of a residential consumer, suggest suitable tariff o achieve energy conservation and reduction in energy bill.
9	Estimate energy saving by improving power factor and load factor for given cases.
10	Prepare a sample energy audit questionnaire for the given industrial facility.
11 a	Prepare an energy audit report (phase-I)
11 b	Prepare an energy audit report(phase-II)
11 c	Prepare an energy audit report.(phase-III)
12	Determination of rating of Inverter capacity for household applications

**GENERAL INSTRUCTIONS FOR LABORATORY CLASSES****DO'S**

1. Without Prior permission do not enter into the Laboratory.
2. While entering into the LAB students should wear their ID cards.
3. The Students should come with proper uniform.
4. Students should sign in the LOGIN REGISTER before entering into the laboratory.
5. Students should come with observation and record note book to the laboratory.
6. Students should maintain silence inside the laboratory.
7. Circuit connections must be checked by the lab-in charge before switching the supply

**DONT'S**

8. Students bringing the bags inside the laboratory..
9. Students wearing slippers/shoes insides the laboratory.
10. Students scribbling on the desk and mishandling the chairs.
11. Students using mobile phones inside the laboratory.
12. Students making noise inside the laboratory.
13. Students mishandle the devices.
14. Students write anything on the devices

**ELECTRICAL CIRCUIT ANALYSIS LABORATORY**

**Practical No.1: Analyze star labeled electrical apparatus and compare the data sheet (Pamphlet) of various star ratings.**

**I Practical Significance**

Every electrical engineer must have the knowledge of energy consumption of electrical appliances he/she is using. Identification of suitable star labeled appliance helps in comparison of energy efficiency, running cost while purchasing new machine/equipment. Also efficient appliance reduces carbon emission thus protecting our environment.

**II Relevant Program Outcomes (POs)**

- **Discipline knowledge:** Apply Electrical Engineering knowledge to solve broad based Electrical Engineering related problems.
- **Environment and sustainability:** Apply Electrical engineering solutions also for sustainable development practices in societal and environmental contexts.
- **Engineering tools:** Apply relevant Electrical technologies and tools with an understanding of the limitations.
- **Ethics:** Apply ethical principles for commitment to professional ethics, responsibilities and norms of the practice also in the field of electrical engineering.
- **Communication:** Communicate effectively in oral and written form.

**III Relevant program specific Outcomes (PSOs)**

- Maintain various types of rotating and static electrical equipment.

**IV Competency and Skills**

- This practical is expected to develop the following skills for the industry identified competency: **Undertake energy conservation and energy audit.**

**V Relevant Course Outcome(s)**

- Interpret energy conservation policies in India.
- Implement energy conservation techniques in electrical machines.

**VI. Practical Outcome**

- **Analyze star labeled electrical apparatus and compare the data sheet (Pamphlet) of various star ratings.**

**VII. Minimum Theoretical Background**

- Construction & working of different types of electrical appliances.
- Interpretation of the features with their technical specifications.
- Size/Rating of electrical equipment.
- Energy consumption of equipment.

**VIII Practical set-up/ Circuit diagram /Work Situation**

Use catalogues of any three same size star labeled appliances, (For example, Three T.V.'s and three refrigerators) of different manufacturers.

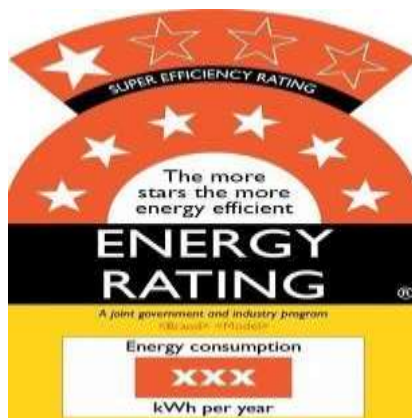

**IX Resources Required**

Sr. No.	Name of Resource	Suggested Broad Specification	Quantity
1	Catalogues by different manufacturers of Refrigerators.	Three star, 165litres.	01
2		Four star, 165 litres.	01
3		Five star,165 litres	01
4	Catalogues by different manufacturers of Televisions.	Three star, 32"	01
5		Four star, 32"	01
6		Five star, 32"	01
7	Catalogues by different manufacturers of Air conditioners.	Two star, one ton	01
8		Three star, one ton	01
9		Four star, one ton	01

**X Precautions to be followed:**

1. While comparing two models make sure that models are manufactured in the same year.
2. Also models we are comparing should be of same size/capacity.

**XI Procedure**

1. Get three catalogues by different manufacturer of refrigerators, but same size/capacity, same year of manufacturing.
2. Look into the star label & note down annual energy consumption.
3. Calculate the annual running cost as per the tariff (cost per unit) in your area.\*
4. Calculate the annual interest on the purchase cost assuming suitable rate of interest, say 8%. Per annum\*\*

5. Add this annual interest on purchase cost to the annual running cost to get the total yearly expenses of the equipment.
6. Assume a reasonable life span for the electrical appliance. (Refer to Table 1.1)
7. Multiply total yearly cost with the average life span of the equipment to get life term expenses for the equipment.
8. Add this life term expense to the purchase price to get life term cost of the equipment.
9. Judge which equipment is a better choice in the long run.
10. Repeat the above steps for other electrical appliances.

. \* **AnnualRunningcost** =

$$(Kwh \text{ per year mentioned on the starlabel}) \times \text{Tariff in your area}$$

\*\* **Annual interest** = Purchase cost x Rate of Interest/100

**Table 1.1:**

Sr.No.	Electrical Appliance	Average Life in years
<b>1</b>	<b>LED TV</b>	<b>18</b>
<b>2</b>	<b>Refrigerator</b>	<b>15</b>
<b>3</b>	<b>Split Air conditioner</b>	<b>20</b>

**XII Resources Used**

Sr. No.	Name of Resource	Broad Specifications		Quantity	Remarks (If any)
		Make	Details		
1.					
2.					
3.					
4.					
5.					
6.					
7.					
8.					
9.					

**XIII Actual Procedure Followed** (use blank sheet if space is not sufficient)

.....

.....

.....

.....

**XIV Precautions Followed**

.....

.....

.....

.....

**XV Observations and Calculations** (use blank sheet if space is not sufficient)

**Electrical Appliance No.1:**

**Size /Capacity –**

**Average life of the appliance-**

Sr. No.	Star rating of the appliance	Annual Energy consumption in Kwh	Model /year	Features if any	Annual interest on purchase cost	Annual Running cost	Total yearly expense =col.6 + col.7	Life term expense = col.8x life in years	Life term cost= Purchase cost+col.9
1	2	3	4	5	6	7	8	9	10
1									
2									
3									
4									

**Electrical Appliance No.2:**

Size /Capacity –

Sr. No	Star rating of the appliance	Annual Energy consumption in Kwh	Model/ year	Features if any	Annual interest on purchase cost	Annual Running cost	Total yearly expense =col.6+col.7	Life term expense = col.8x life in years	Life term cost=Purchase cost+col.9
1	2	3	4	5	6	7	8	9	10
1									
2									
3									
4									

**Electrical Appliance No.3:**

Size /Capacity –

Sr. No.	Star rating of the appliance	Annual Energy consumption in Kwh	Model/ year	Features ,if any	Annual interest on purchase cost	Annual Running cost	Total yearly expense =col.6+col.7	Life term expense = col.8x life in years	Life term cost=Purchase cost+col.9
1	2	3	4	5	6	7	8	9	10
1									
2									
3									
4									



**XVI Results**

.....  
.....  
.....  
.....

**XVII Interpretation of Results** (Write meaning of the above obtained results)

.....  
.....  
.....  
.....

**XVIII. Conclusions** (Actions/decisions to be taken based on the interpretation of cost analysis)

.....  
.....  
.....  
.....

**XIX. Practical Related Questions**

*Note: Below given are few sample questions for reference. Teachers **must design more such questions so as to ensure the achievement of identified CO.***

1. Write the significance of star rating.
2. Write the factors to be considered while comparing star rated products.
3. List the products for which labeling are mandatory.
4. Write the meaning of EER written on star label of Air conditioner.

**[Space for answers]**

.....  
.....  
.....  
.....  
.....  
.....  
.....  
.....  
.....  
.....



**XX. References / Suggestions for Further Reading**

1. [www.energyrating.gov.au/](http://www.energyrating.gov.au/)
2. [www.bijlibachao.com](http://www.bijlibachao.com)
3. [www.bee\\_india.nic.in](http://www.bee_india.nic.in)
4. [www.worldenergy.org](http://www.worldenergy.org)
5. Catalogues of various manufacturers

**XXI. Assessment Scheme**

<b>Performance Indicators</b>		<b>Weight-age</b>
<b>Process related: 15 Marks</b>		<b>60%</b>
1	Market survey and data search	10 %
2	Collection of catalogues and information from website/distributers	20 %
3	Preparation of datasheet	20 %
4	Working in team	10 %
<b>Product related:10 Marks</b>		<b>40%</b>
5	Calculation of life time cost	05 %
6	Interpretation of results	10 %
7	Conclusions	10 %
8	Practical related questions	10 %
9	Submitting the journal in time	05%
<b>Total (25 Marks)</b>		<b>100 %</b>

*Names of Student Team Members*

1. ....
2. ....
3. ....
4. ....

<b>Marks Obtained</b>			<b>Dated signature of Teacher</b>
<b>Process Related (15)</b>	<b>Product Related (10)</b>	<b>Total (25)</b>	

**Practical No.2: Determine the reduction in power consumption in star mode operation of Induction motor compared to delta mode at No load/light load.**

**I. Practical Significance**

Every Electrical Engineer must be aware of the fact that if an oversized induction motor (with respect to the load requirements) is used, it draws unnecessary excess power. In order to conserve energy without going for replacement, the best way is to use star delta starter/ converter at reduced loads.

**II. Relevant Program Outcomes (POs)**

- **Discipline knowledge:** Apply Electrical Engineering knowledge to solve broad based Electrical Engineering related problems.
- **Experiments and practice:** Plan to perform experiments and practices to use the results to solve broad-based Electrical Engineering problems.
- **Engineering tools:** Apply relevant Electrical technologies and tools with an understanding of the limitations.
- **Ethics:** Apply ethical principles for commitment to professional ethics, responsibilities and norms of the practice also in the field of electrical engineering.
- **Communication:** Communicate effectively in oral and written form.

**III. Competency and Skills**

- This practical is expected to develop the following skills for the industry identified competency: **Undertake energy conservation and energy audit.**

**IV. Relevant Course Outcome(s)**

Implement energy conservation techniques in electrical machines.

**V. Practical Outcome**

Determine the reduction in power consumption in star mode operation of Induction motor compared to delta mode, under no load/ light load conditions.

**VI. Minimum Theoretical Background**

- Efficiency of motor is a function of load.
- In star mode, as the reduced voltage is applied to the motor terminals, current also reduces hence power drawn by the motor reduced.

**VII. Practical set-up/ Circuit diagram /Work Situation**

Fig 3.1

This is a suggested setup. Any other alternative with facility to load (and read the load) the induction motor from no load to full load may be used.

**VIII. Resources Required**

Sr. No.	Name of Resource	Suggested Broad Specification	Quantity
1	Three phase Induction motor	3hp,415 V.	01
2	Star-Delta converter	Suitable for the above motor	01
3	Lamp bank	5 kW	01
4	Wattmeter	Single phase 5/10Amp, 250/500V, 1500W	02
5	AC Voltmeter	0-500 V.	01
6	AC Ammeter	0-10 A	01
7	DC Voltmeter	0-300V	01
8	DC Ammeter	0-20A	01
9	Rheostat	800 Ohms,1A.	01

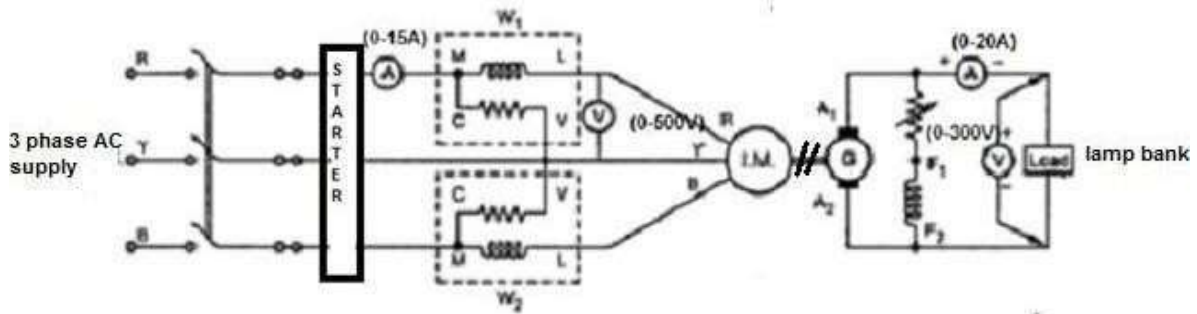
**IX. Precautions to be followed:**

1. Make sure that the main switch is in 'OFF' position while making connections.
2. Make sure load is off at the beginning of the practical.

**X. Procedure**

1. Make the connections as per the circuit diagram shown in Fig. 3.1.
2. Switch on the supply by keeping the Star Delta Converter in delta mode.
3. Increase the field excitation of the generator to bring up to the rated voltage.
4. Note down the readings of all the meters at no load.
5. Gradually increase the lamp load in steps, until motor is loaded up to 30% of full load.
6. For each step note down all meter readings.
7. With Star Delta Converter, change the motor terminals to star mode.
8. Repeat the step no.5 & 6.
9. Switch off the load.

- 10. Decrease the field excitation of generator and STOP the motor.
- 11. Switch OFF the supply.

**XI. Resources Used**

Sr. No.	Name of Resource	Broad Specifications		Quantity	Remarks (If any)
		Make	Details		
1.					
2.					
3.					
4.					
5.					
6.					

**XII. Actual Procedure Followed** (use blank sheet if space is not sufficient)

.....

.....

.....

.....

.....

.....

.....

.....

.....

.....

.....

.....

.....

.....

.....

.....

.....

.....

.....

.....

.....

.....

**XIII. Precautions Followed**

.....

.....

.....

.....

.....

.....

.....

.....

.....

.....

.....

.....

.....

.....

.....

.....

.....

.....

.....

.....

.....

.....

**XIV. Observations and Calculations** (use blank sheet if space is not sufficient)

Rated power of the Induction motor,  $W_r = \underline{\hspace{2cm}}$  kw

Full load efficiency of Induction motor,  $\eta_m = \underline{\hspace{2cm}}$  (As per name plate details)

Full load efficiency of Generator,  $\eta_g = \underline{\hspace{2cm}}$  (As per name plate details)

Delta mode of operation	Motor side			Generator side		Motor output, $W_o = (V_o I_o) \eta_g$	Percentage Loading	Efficiency of Induction motor = $W_o / W_i$
	$V_i$ , volt	$I_i$ , amp	$W_i$ , watt ( $W_1 + W_2$ )	$V_o$ , volt	$I_o$ , amp			
Star mode of operation								

$$\% \text{Loading} = \frac{V_o I_o \times \eta_m \times 100}{W_r}$$

**XV. Results**

.....  
 .....  
 .....  
 .....

**XVI. Interpretation of Results** (Write meaning of the above obtained results)

.....  
 .....  
 .....  
 .....

**XVII. Conclusions** (Actions/decisions to be taken based on the interpretation of results)

.....  
 .....  
 .....  
 .....

**XVIII. Practical Related Questions**

*Note: Below given are few sample questions for reference. Teachers **must design more such questions so as to ensure the achievement of identified CO.***

- 1. List the energy conservation techniques in Induction motors.
- 2. Most of the induction motors are delta connected. Give reason.
- 3. Name the starters used for small rating induction motors.

[Space for answers]

.....

.....

.....

.....

.....

.....

.....

.....

.....

.....

.....

.....

.....

.....

.....

.....

.....

.....

.....

.....

.....

.....



**XIX. References / Suggestions for Further Reading**

Sr. No.	Title of Book	Author	Publication
1	Laboratory Manual for Electrical Machines	Dr.D.P.Kothari B.S.Umre	I K International Publishing House Pvt. Ltd. ISBN-13 978-9385909757
2	Electrical engineering Laboratory Practice	P.Tiwari	S.K.Kataria& Sons ISBN-13 978-8189757892
3	Laboratory Courses in Electrical Engineering	S. G. Tarnekar	S.Chand& Company ISBN-13 978-8121901048

**XX. Assessment Scheme**

Performance Indicators		Weightage
<b>Process related: 15 Marks</b>		<b>60%</b>
1	Preparation of experimental set up	10 %
2	Setting and operation	20 %
3	Safety measures	20 %
4	Observations and Recording	10 %
<b>Product related: 10 Marks</b>		<b>40%</b>
1	Interpretation of result and Conclusion	20 %
2	Answer to sample questions	10 %
3	Submission of report in time	10 %
<b>Total (25 Marks)</b>		<b>100 %</b>

*Names of Student Team Members*

1. ....
2. ....
3. ....
4. ....

Marks Obtained			Dated signature of Teacher
Process Related (15)	Product Related (10)	Total (25)	

### **Practical No.3: Use APFC / PFC unit for improvement of p. f. of electrical load.**

#### **I. Practical Significance:**

Improvement in the PF increases the power handling capacity, improves voltage regulation, and reduces the power loss which results in the reduction of energy bill. Reactive power generators help offset the non-working **power** required by the loads, thereby **improving** the **power factor**. This practical enables the student to make use of power factor correction unit to improve p.f and achieve energy conservation.

#### **II. Relevant Program Outcomes (POs)**

- **Discipline knowledge:** Apply Electrical Engineering knowledge to solve broad based Electrical Engineering related problems.
- **Experiments and practice:** Plan to perform experiments and practices to use the results to solve broad-based Electrical Engineering problems.
- **Engineering tools:** Apply relevant Electrical technologies and tools with an understanding of the limitations.
- **Ethics:** Apply ethical principles for commitment to professional ethics, responsibilities and norms of the practice also in the field of electrical engineering.
- **Communication:** Communicate effectively in oral and written form.

#### **III. Competency and Skills**

- This practical is expected to develop the following skills for the industry identified competency: **Undertake energy conservation and energy audit.**

#### **IV. Relevant Course Outcome(s)**

- Implement energy conservation techniques in electrical machines.
- Apply energy conservation techniques in electrical installations.
- Use Co-generation and relevant tariff for reducing losses in facilities.

#### **V. Practical Outcome**

Use APFC / PFC unit for improvement of p. f. of electrical load.

#### **VI. Minimum Theoretical Background**

Improved power factor increase the **efficiency** of system and devices. Improved power factor **reduces** voltage drops, the size of a conductors/cables leading to monetary reduction in the cost of the conductors.

The most practical and economical power factor correction device is the capacitor. It improves the power factor because the effects of capacitance are exactly opposite from those of inductance.

**VII. Practical set-up/ Circuit diagram /Work Situation**

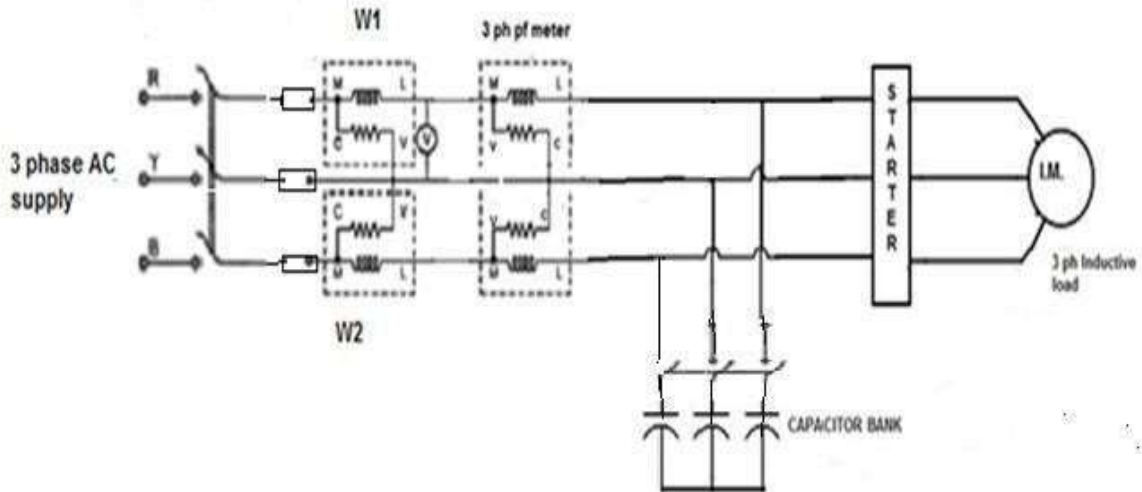

**VIII. Resources Required**

Sr. No.	Name of Resource	Suggested Broad Specification	Quantity
1	Three phase Induction motor	3 hp, 415 Volts	01
2	AC Voltmeter	0 – 500V	01
3	AC Clamp on ammeter	0-20A	01
4	PF meter	Three phase 5/10Amp, 300/600V	01
5	Wattmeter	Single phase, 5/10A, 300/600V	02
6	Capacitor Bank	3 phase, 50Hz, 1 KVAR (in steps of 0.2KVAR)	01

**IX. Precautions to be followed**

1. Make sure that the main switch is in 'OFF' position while making connections.
2. Make sure load is off at the beginning of the practical.
3. Make sure all capacitors are properly discharged before connection.

**X. Procedure**

1. Make the connections as per the circuit diagram.
2. Keep the switch of capacitor bank in off position..
3. Switch "ON" the supply.
4. Start the Induction motor at no load or light load.
5. Note down the readings of current at supply side (Before capacitor bank) and load side ( after capacitor bank) using clamp on ammeter.
6. Note down the readings of wattmeter's, p.f meter, and voltmeter.
7. Switch ON switches of appropriate capacitor bank in steps.
8. For each step note down all meter readings. (minimum four readings)
9. Switch OFF the capacitor bank one by one.
10. Stop the Motor.
11. Switch 'OFF' the supply.

**XI. Resources Used**

Sr. No.	Name of Resource	Broad Specifications		Quantity	Remarks (If any)
		Make	Details		
1.					
2.					
3.					
4.					
5.					
6.					

**XII. Actual Procedure Followed** (use blank sheet if space is not sufficient)

.....

.....

.....

.....

**XIII. Observations and Calculations** (use blank sheet if space is not sufficient)

Sr. No	Capacitor Bank	Supply Voltage V volts	Supply current, Is amps	Load Current, IL,amps	Total Active power,P watt W <sub>1</sub> +W <sub>2</sub>	PF meter reading cosφ	Total Reactive power,Q, VAR √3(W <sub>1</sub> -W <sub>2</sub> )	Line pof = Cos((tan <sup>-1</sup> √3(W <sub>1</sub> W <sub>2</sub> )/ (W <sub>1</sub> +W <sub>2</sub> )))
1	OFF							
2	C <sub>1</sub>							
3	C <sub>2</sub>							
4	C <sub>3</sub>							

Power factor calculation:

Power factor correction capacitor's capacitance calculation:

$$S_{corrected(kVA)} = \frac{P_{(kW)}}{PF_{corrected}}$$

**XIV. Results**

.....  
.....  
.....  
.....

**XV. Interpretation of Results**(Write meaning of the above obtained results)

.....  
.....  
.....  
.....

**XVI. Conclusions** (Actions/decisions to be taken based on the interpretation of results)

.....  
.....  
.....  
.....

**XVII. Practical Related Questions**

*Note: Below given are few sample questions for reference. Teachers **must design more such questions so as to ensure the achievement of identified CO.***

1. Write the advantages of power factor correction.
2. Explain the working of IPFC unit.
3. Write different methods by which power factor can be improved.
4. Write the disadvantages of manual power factor correction unit.
5. Write the advantages of APFC unit.

[Space for answers]

.....  
.....  
.....  
.....  
.....  
.....



**XVIII. References / Suggestions for Further Reading**

Sr. No.	Title of Book	Author	Publication
1	Laboratory Manual for Electrical Machines	Dr.D.P.Kothari B.S.Umre	I K International Publishing House Pvt. Ltd. ISBN-13 978-9385909757
2	Electrical engineering Laboratory Practice	P.Tiwari	S.K.Kataria& Sons ISBN-13 978-8189757892
3	Laboratory Courses in Electrical Engineering	S. G. Tarnekar	S.Chand& Company ISBN-13 978-8121901048

**XIX. Assessment Scheme**

Performance Indicators		Weightage
<b>Process related: 15 Marks</b>		<b>60%</b>
1	Preparation of experimental set up	10 %
2	Setting and operation	20 %
3	Safety measures	20 %
4	Observations and Recording	10 %
<b>Product related: 10 Marks</b>		<b>40%</b>
1	Interpretation of result and Conclusion	20 %
2	Answer to sample questions	10 %
3	Submission of report in time	10 %
<b>Total (25 Marks)</b>		<b>100 %</b>

*Names of Student Team Members*

1. ....
2. ....
3. ....
4. ....

Marks Obtained			Dated signature of Teacher
Process Related (15)	Product Related (10)	Total (25)	

## **Practical No. 4: Compare power consumption of (Fluorescent and LED) lighting.**

### **I. Practical Significance**

The electrical diploma engineers are expected to know all about the benefits of energy efficiency and find out how society (Individual or group) and environment is benefited by using Energy efficient lighting.

### **II. Relevant Program Outcomes (POs)**

- **Engineering tools:** Apply relevant electrical technologies and tools with an understanding of the limitations.
- **The Engineer and society:** Assess societal, health, safety, legal and cultural issues and the consequent responsibilities relevant to practice in field of electrical engineering.
- **Environment and Sustainability:** Apply electrical Engineering solutions also for sustainable development practice in societal and environmental contexts.
- **Ethics:** Apply ethical principles for commitment to professional ethics, responsibilities and norms of the practice also in the field of electrical engineering.
- **Communication:** Communicate effectively in oral and written form.

### **III Relevant program specific Outcomes (PSOs)**

- Maintain various types of rotating and static electrical equipment.

### **IV. Competency and Practical Skills**

This practical is expected to develop the skills of identifying the energy efficient lamps or gear based on the test data.

### **V. Relevant Course Outcome**

- a) Apply energy conservation techniques in electrical installation.
- b) Use Co-generation and relevant tariff for reducing losses in facilities.

### **VI. Practical Outcome (PrOs)**

Compare power consumption of (Fluorescent and LED) lighting

### **VII. Minimum Theoretical Background**

Construction and working of different types of lamps and control gears. Interpretation of their specification with their technical features. Selection of lamps based on type of lighting system. To connect the lamps in the circuit with control gear and proper meters to measure electrical power drawn by the lamp.



**VIII. Practical set-up/ Circuit diagram/ Work situation**

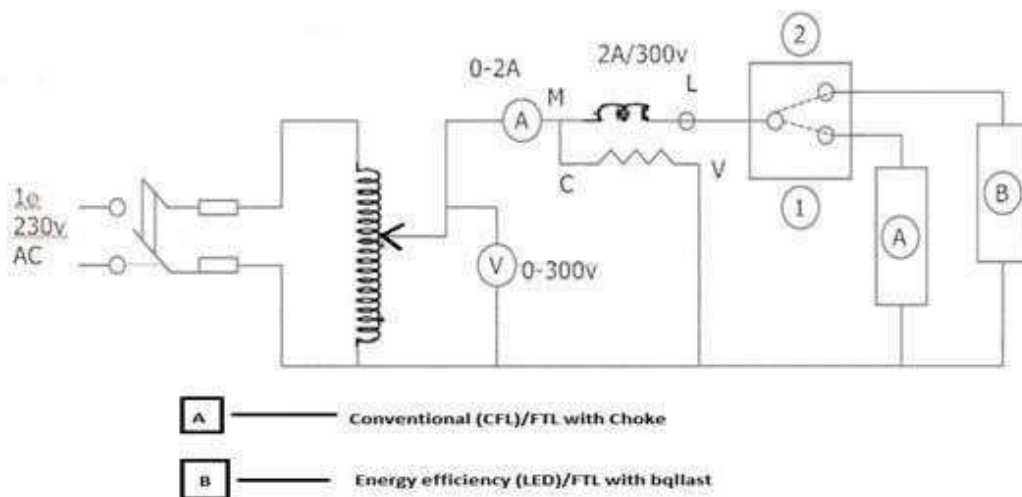

**IX. Resources Required**

Sr. No	Resource required	Specification	Quantity
1	1-Phase Auto Transformer	2KVA, 0-250V	1
2	AC Ammeter	0-1-2/0-2.5-5 Amp	2
3	AC Voltmeter	0-300 Volt	1
4	Wattmeter(LPF)	1-2/300,2.5-5/300	2
5	Lux-meter	Digital type	1
6	FT with induction choke	230V,50Hz	1
7	FT with electronic ballast	230V,50Hz	1
8	CFL of different rating	5,12,18,25,55W	1-each
9	LED lamps of Different ratings	2,5,8,12,18,25,35W	1-each
10	Two way piano switch	5Amp/230Volt	1

**X. Precautions to be followed**

1. Select proper range of meters.
2. Ensure the position of auto transformer at zero position before switching on the supply.
3. Position of Lux-meter must be at the same distance (i.e. approximately 1.5m) from light source for the measurement of illumination.

**XI. Procedure**

1. Make the connection as per the circuit shown.
2. Check and adjust the zero settings of all the meters.
3. Keep the auto transformer at zero position.
4. Switch on the supply.
5. Adjust the voltage to the rated voltage of the lamps.
6. Keep the two way switch at position 1.
7. Observe shoots up in starting current.
8. Note down the meter readings and measure illumination with lux-meter.
9. Reduce the voltage and note down the minimum voltage at which the lamp glows bright/ ignite.

10. Change the switch to position 2.
11. Repeat step 7 to9.
12. Switched off the supply.

**XII. Resources Used**

Sr. No	Resource Used	Broad Specification with Make	Quantity	Remark (If Any)

**XIII. Actual Procedure Followed**

.....  
 .....  
 .....  
 .....

**XIV. Observations and Calculations**

Comparison of power consumption of FTL with LED.

Type of lamp	Rating in Watts	Current I in Amp	Voltage V in Volts	Power consumed in Watts	On Illumination the working Plane in Lumen/sq.m
FTL-18					
FTL-21					
LED					

**Comparison of power consumption of FTL with induction choke and Electronic Ballast.**

Type of Ballast	Voltage required to ignite the FTL	Current in Amps	Power in Watts	Illumination on the working plane Lumen/sq.m
<b>Conventional</b>	Rated :			
	Minimum :			
<b>Electronic</b>	Rated :			
	Minimum :			

Type of Luminary	Lamp Efficacy	Cost in Rs.	CRI	Life of the luminary

**XV. Results**

.....  
 .....  
 .....  
 .....

**XVI. Interpretation of Results**

.....  
 .....  
 .....  
 .....

**XVII. Conclusion (Action/ decision to be taken based on interpretation of result)**

.....  
.....  
.....  
.....

**XVIII. Practical Related Questions**

1. Compare the electronics and conventional ballast on points of difference?
2. The current shoots in conventional choke at the time of starting. Explain.
3. Distinguish between CFL and LED.
4. Explain the working of electronic ballast.
5. Discuss the factors considered while adapting lamp replacement technique for energy conservation.
6. Prepare comparative analysis of 3 LED and FTL lamp in the format given below. Suggest the efficient light.
7. Explain the demerits of CFL.
8. Discuss the significance of colour rendering index. Comment on the above data.

[Space for answers]

.....  
.....  
.....  
.....  
.....  
.....  
.....  
.....  
.....  
.....  
.....  
.....  
.....  
.....  
.....  
.....  
.....  
.....  
.....  
.....  
.....



**XIX. References/ Suggestions for further reading**

- Website of BEE; [www.bee-india.nic.in](http://www.bee-india.nic.in).
- AkshayUrja News Bulletin; [www.mnes.nic.in](http://www.mnes.nic.in).
- [www.worldenergy.org](http://www.worldenergy.org).
- Catalogues of different manufacturers of CFL, LED, and FTL.
- [www.energyrating.gov.in](http://www.energyrating.gov.in)

**XX. Suggested Assessment Scheme**

Performance Indicators		Weightage in %
<b>Process related: 15 Marks</b>		<b>60%</b>
1.	Preparation of experimental set up	10%
2.	Setting and connections	20%
3.	Safety Measures	10%
4.	Observations and Recording	20%
<b>Product related: 10 Marks</b>		<b>40%</b>
5.	Interpretation of result and Conclusion	20%
6.	Answer to sample Questions	10%
7.	Prompt Submission of completed report	10%
<b>Total (25 Marks)</b>		<b>100%</b>

*Names of the Team Members:*

1. ....
2. ....
3. ....
4. ....

Marks Obtained			Date and signature of course teacher
Process Related (15)	Product Related (10)	Total (25)	

## **Practical No. 5: Determine Net Energy Saving by Lamp replacements.**

### **I. Practical Significance**

The electrical diploma engineers are expected to suggest replacement of inefficient lamps in the existing installations with energy efficient lighting techniques. Such techniques reduce the burden on supply utility on large extent by reducing energy wastage, also help the consumers by reducing energy bills.

### **II. Relevant Program Outcomes (POs)**

- **Experiments and Practice:** Plan to perform experiment and practices to use the results to solve broad-based electrical engineering problems.
- **Engineering tools:** Apply relevant electrical technologies and tools with an understanding of the limitations.
- **The Engineer and society:** Assess societal, health, safety, legal and cultural issues and the consequent responsibilities relevant to practice in field of electrical engineering.
- **Environment and Sustainability:** Apply electrical Engineering solutions also for sustainable development practice in societal and environmental contexts.
- **Ethics:** Apply ethical principles for commitment to professional ethics, responsibilities and norms of the practice also in the field of electrical engineering.
- **Communication:** Communicate effectively in oral and written form.

### **III. Competency and Practical Skills**

This practical is expected to develop the skills of identifying the energy efficient lamps or gear based on the test data.

### **IV. Relevant Course Outcome**

Apply energy conservation techniques in electrical installation.

### **V. Practical Outcome (PrOs)**

Determine Net Energy Saving by Lamp replacements..

### **VI. Minimum Theoretical Background**

The knowledge of different types of luminaries with luminaire, control gears for efficient lighting system with their application and other technical features. Methods of lighting schemes based on the need of facility.

**VII. Practical set-up/ Circuit diagram/ Work situation/Plan of the site.**

**(Draw to the scale of existing plan of lighting system by clearly indicating the position of electrical installation, Doors, windows and working table/ plane. Attach extra page if needed.)**

**VIII. Resources Required**

<b>Sr. No</b>	<b>Resource required</b>	<b>Specification</b>	<b>Quantity</b>
1.	Lux-meter	Digital type	1
2.	Multimeter	Digital type	1
3.	Clamp-on meter	Digital type	1
4.	Pamphlets of efficient lighting	Any manufacturer	3 samples



**IX. Precautions to be followed**

- Select proper range of meters.
- Ensure all the switches are off before starting the work.
- Measurement of lumen must be carried out on working table where the illumination is desired.

**X. Procedure**

1. Visit the place allocated to your group for the above purpose.
2. Draw the existing electrical installation plan by indicating the position of lamps, windows and doors.
3. Tabulate the power rating, type, condition and method of control of each lamp by marking code/ number to each lamp.
4. Summarize the total power consumption of the existing system.
5. Replace all the existing lamps by energy efficient lamps and then calculate total power conservation.
6. Estimate the effective electric power conserved.

**XI. Resources Used**

Sr. No	Resource Used	Broad Make	Specification	with	Quantity	Remark (If Any)

**XII. Actual Procedure Followed**

.....

.....

.....

.....

.....

.....

.....

.....

.....

.....

.....

.....

.....

.....

.....

.....

.....

.....

.....

.....

.....

.....

.....

**XIII. Observations and Calculations**

Assume the lamps are in operation for 8 hours/day and cost per energy unit (kWh) = Rs.3.00

Number of days in particular month: \_\_\_\_\_

Sr. No/ Lamp code	Power rating of existing lamp	Energy consumption per month by existing lamp	Power rating of efficient lamp	Energy consumption per month by efficient lamp	Net Energy saving/ month (e=b-d)
	(a)	(b)	(c)	(d)	

**Net saving in monthly bill in rupees = Net Energy Saving X Cost per unit**

**XIV. Results**

.....  
 .....  
 .....  
 .....

**XV. Interpretation of Results**

.....  
 .....  
 .....

**XVI. Conclusion (Action/ decision to be taken based on interpretation of result)**

.....  
 .....  
 .....



**XVIII. References/ Suggestions for further reading**

- Website of BEE; [www.bee-india.nic.in](http://www.bee-india.nic.in).
- AkshayUrja News Bulletin; [www.mnes.nic.in](http://www.mnes.nic.in).
- [www.worldenergy.org](http://www.worldenergy.org).
- Cat log of different manufacturers of CFL, LED, FTL.

**XIX. Suggested Assessment Scheme**

Performance Indicators		Weightage in %
<b>Process related: 15 Marks</b>		<b>60%</b>
1.	Draw the Layout of electrical Installation by coding/Demarking	20%
2.	Plan to carry out measurement	10%
3.	Safety Measures/Precaution	10%
4.	Observations and Recording	20%
<b>Product related: 10 Marks</b>		<b>40%</b>
5.	Interpretation of result and Conclusion	20%
6.	Answer to sample Questions	10%
7.	Prompt Submission of completed report	10%
<b>Total (25 Marks)</b>		<b>100%</b>

*Names of the Team Members:*

1. ....
2. ....
3. ....
4. ....

Marks Obtained			Date and signature of course teacher
Process Related (15)	Product Related (10)	Total (25)	

## **Practical No. 6: Determine Energy conservation in Fan by using Electronic Regulator.**

### **I. Practical Significance**

The electrical diploma engineers are expected *to* know about the benefits of energy efficiency and the use energy efficient regulators to regulate the speed of electric fan. Able to select proper type of regulator based on the requirement and availability.

### **II. Relevant Program Outcomes (POs)**

- **Engineering tools:** Apply relevant electrical technologies and tools with an understanding of the limitations.
- **The Engineer and society:** Asses societal, health, safety, legal and cultural issues and the consequent responsibilities relevant to practice in field of electrical engineering.
- **Environment and Sustainability:** Apply electrical Engineering solutions also for sustainable development practice in societal and environmental contexts.
- **Ethics:** Apply ethical principles for commitment to professional ethics, responsibilities and norms of the practice also in the field of electrical engineering.
- **Communication:** Communicate effectively in oral and written form.

#### **Relevant program specific Outcomes (PSOs)**

- Maintain various types of rotating and static electrical equipment.

### **III. Competency and Practical Skills**

This practical is expected to develop the skills of identifying the energy efficient fans and regulator from the catalogue of different manufacturers as well from the practical test data gear based on the test data.

### **IV. Relevant Course Outcome**

Apply energy conservation techniques in electrical installation.

### **V. Practical Outcome (PrOs)**

Determine Energy conservation in Fan by using Electronic Regulator

### **VI. Minimum Theoretical Background**

Construction and working of different types of conventional an electronic regulators. Interpretation of their specification and technical features. Selection of regulators based on rating and type of fan. To connect the fan in the electric circuit with regulate the speed and connect proper meters to measure electrical power drawn.

**VII. Practical set-up/ Circuit diagram/ Work situation**

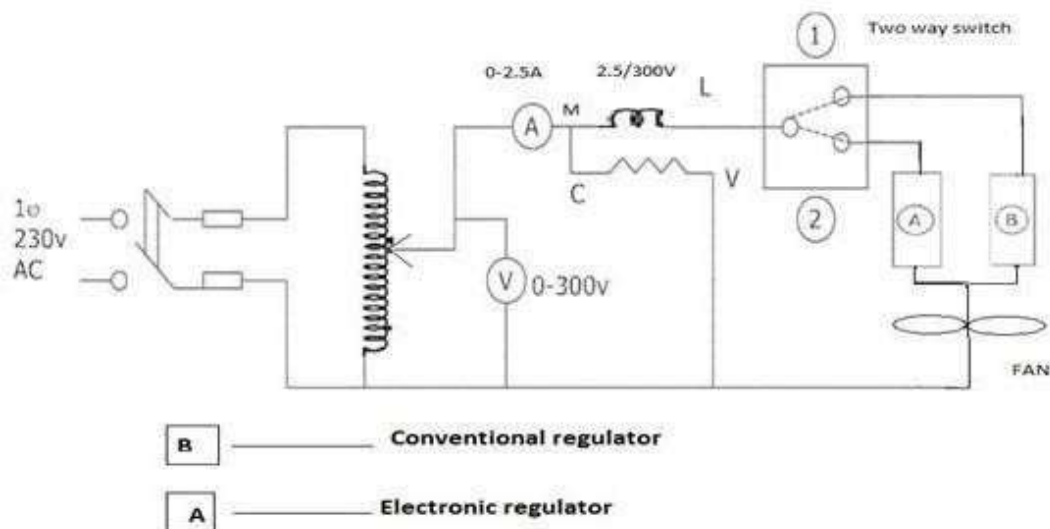

Fig 7.1

**VIII. Resources Required**

Sr. No	Resource required	Specification	Quantity
1	1-Phase Auto Transformer	2KVA, 0-250V	1
2	AC Ammeter	0-1-2/0-2.5-5 Amp	2
3	AC Voltmeter	0-300 Volt	1
4	Wattmeter(LPF)	1-2/300,2.5-5/300	2
5	Conventional regulator	230V,50Hz	1
6	Electronic (Step type)	230V,50Hz	1
7	Electronic (Smooth variable)	230V,50Hz	1
8	Tachometer	Digital non-contact type	1
9	Two way piano switch	5Amp/230Volt	1

**IX. Precautions to be followed**

1. Select proper range of meters.
2. Ensure the position of auto transformer at zero position before switching on the supply.

**X. Procedure**

1. Make the connection as per the circuit shown in fig 7.1.
2. Check and adjust the zero settings of all the meters.
3. Keep the auto transformer at zero output voltage position.
4. Switch on the supply.
5. Keep the two way switch in position-1 to connect the convention regulator in the circuit.

6. Note down the meter readings and measure the speed.
7. Now keep the two way switch in position-2 to connect the electronic regulator in the circuit.
8. Repeat step-6
9. Observe the jerk operation of motor while change the steps of regulator.

**XI. Resources Used**

Sr. No	Resource Used	Broad Specification with Make	Quantity	Remark (If Any)

**XII. Actual Procedure Followed**

.....  
 .....  
 .....  
 .....

**XIII. Observations and Calculations**

Comparison of power consumption in regulators.

Type of Regulator with specification	Steps	Current I in Amp	Voltage V in Volts	Power consumed in Watts	Speed in rpm
<b>Conventional</b>	1				
	2				
	3				
	4				
<b>Electronic</b>	1				
	2				
	3				
	4				

**XIV. Results**

.....  
.....  
.....  
.....

**XV. Interpretation of Results**

.....  
.....  
.....  
.....

**XVI. Conclusion (Action/ decision to be taken based on interpretation of result)**

.....  
.....  
.....  
.....

**XVII. Practical Related Questions**

1. Illustrate how electronic regulators differ from conventional regulator (resistive type).
2. Draw a neat circuit of an electronic fan regulator; explain its working.
3. Distinguish between the electronic and conventional fan regulators.
4. Illustrate the factors considered while replacing conventional fan regulators with the electronic regulators.
5. Write the reasons for harmonic contamination in supply due to electronic devices and its impact on other appliances.

**(Space for Answer)**

.....  
.....  
.....  
.....  
.....  
.....  
.....  
.....  
.....





**XVIII. References/ Suggestions for further reading**

- Website of BEE; [www.bee-india.nic.in](http://www.bee-india.nic.in).
- AkshayUrja News Bulletin; [www.mnes.nic.in](http://www.mnes.nic.in).
- [www.worldenergy.org](http://www.worldenergy.org).
- Catalogues of different manufacturers of CFL, LED, FTL.
- [www.energyrating.gov.in](http://www.energyrating.gov.in)

**XIX. Suggested Assessment Scheme**

Performance Indicators		Weightage in %
<b>Process related: 15 Marks</b>		<b>60%</b>
1.	Preparation of experimental set up	20%
2.	Setting and connections	20%
3.	Safety Measures	10%
4.	Observations and Recording	10%
<b>Product related: 10 Marks</b>		<b>40%</b>
5.	Interpretation of result and Conclusion	20%
6.	Answer to sample Questions	10%
7.	Prompt Submission of completed report	10%
<b>Total (25 Marks)</b>		<b>100%</b>

*Names of the Team Members:*

1. ....
2. ....
3. ....
4. ....

Marks Obtained			Date and signature of course teacher
Process Related (15)	Product Related (10)	Total (25)	

**Practical No. 7: To analyze the energy bill of a commercial consumer and to suggest (if needed) suitable tariff to achieve energy conservation and reduction in energy bill.**

**I. Practical Significance**

The electrical diploma engineers must be able to interpret the electric bill and the tariff schedule of the commercial consumer and expected to suggest suitable tariff applicable to achieve energy conservation and its impact to reduce his/her energy bill.

**II. Relevant Program Outcomes (POs)**

- **Discipline knowledge:** Apply Electrical engineering knowledge to solve broad-based electrical engineering related problems.
- **Engineering tools:** Apply relevant electrical technologies and tools with an understanding of the limitations.
- **The Engineer and society:** Assess societal, health, safety, legal and cultural issues and the consequent responsibilities relevant to practice in field of electrical engineering.
- **Environment and Sustainability:** Apply electrical Engineering solutions also for sustainable development practice in societal and environmental contexts.
- **Ethics:** Apply ethical principles for commitment to professional ethics, responsibilities and norms of the practice also in the field of electrical engineering.
- **Communication:** Communicate effectively in oral and written form.

**III. Competency and Practical Skills**

This practical is expected to develop the skills of identifying the types of the tariffs applicable to the commercial consumer and select a suitable one to achieve the goal of energy efficiency with economy.

**IV. Relevant Course Outcome**

- Interpret energy conservation policies in India
- Implement energy conservation techniques in electrical machines.
- Use Co-generation and relevant tariff for reducing losses in facilities.

**V. Practical Outcome (PrOs)**

To analyze the energy bill of a commercial consumer and to suggest (if needed) suitable tariff to achieve energy conservation and reduction in energy bill

**VI. Minimum Theoretical Background**

Significance of the terms used in electrical power distribution and framing of tariff. Classification of consumer based on amount of energy consumption. Various types of tariff schedule used to calculate energy bill of commercial consumer with their respective merits and demerits.

**VII. Practical set-up/ Circuit diagram/ Work situation/Sample of energy bill (paste here)**

**VIII. Resources Required**

- Electricity bill of commercial consumer for the current/last month.
- Tariff schedule booklet of the relevant supply company/utility.
- Different types of tariff applicable to conserve energy and its impact on reduction in energy bill.

**IX. Precautions to be Followed**

1. Take electricity bill of current/last month.
2. Identify the type of tariff therein.

**X. Procedure**

1. Collect current/last month electricity bill of a commercial consumer.
2. Interpret the type and structure of tariff used to calculate the electricity bill.
3. Interpret the components of the bill.
4. Use different types of tariffs which are applicable to the commercial consumers and calculate the electricity bill.
5. Compare the change in electricity bill charges.
6. Suggest type of tariff which benefits the consumer.

**XI. Resources Used**

Sr. No	Resource Used	Description about Supply Utility/Type of consumer	Remark

**XII. Actual Procedure Followed**

.....  
 .....  
 .....  
 .....

**XIII. Observations and Calculations**

Calculation of energy bill by using different tariffs as applicable to consumer.

Tariff Structure		Total monthly Units consumed at Avg PF	Energy bill (Excluding fixed charges, Taxes and interest)
Cost per Unit	% Incentive on Avg PF		
<b>Total</b>		<b>Units:</b>	<b>Rs:</b>

**Cost of Energy consumed = Units consumed per month X Cost per unit**

**Incentive on PF improvement = Cost of energy consumed X % Incentive on Average**

**PF Energy bill (Excluding fixed charges, Taxes, interest etc.) =**

**Cost of Energy consumed + Incentive on PF improvement**

(Note: Suggest proper tariff structure after analysing actual energy bill with the calculated energy bill by selecting appropriate tariff as applicable.)

**XIV. Results**

.....  
 .....  
 .....  
 .....  
 .....  
 .....  
 .....

**XV. Interpretation of Results**

.....  
.....  
.....  
.....

**XVI. Conclusion (Action/ decision to be taken based on interpretation of result)**

.....  
.....  
.....  
.....  
.....  
.....  
.....  
.....  
.....  
.....  
.....  
.....  
.....  
.....

**XVII. Practical Related Questions**

1. Define Maximum demand tariff.
2. Illustrate the tariff structure used for the above consumers.
3. Explain incentives and penalty on power factor tariff.
4. List out the tariffs used to achieve energy conservation in commercial sector.
5. List the merits and demerits of TOU tariff.
6. Explain the Time-off-Use metering system in energy billing.

**(Space for Answer)**

.....  
.....  
.....  
.....  
.....  
.....  
.....  
.....  
.....  
.....  
.....



**XVIII. References/ Suggestions for further reading**

- [www.mahadiscom.com](http://www.mahadiscom.com)
- [www.bestundertaking.com](http://www.bestundertaking.com)
- [www.mercindia.org.in](http://www.mercindia.org.in)
- [www.tatapower.ddl.com](http://www.tatapower.ddl.com)
- [www.bescom.org](http://www.bescom.org)

**XIX. Suggested Assessment Scheme**

Performance Indicators		Weightage in %
<b>Process related: 15 Marks</b>		<b>60%</b>
1.	Collection of bill	10%
2.	Interpreting tariff for given bill	20%
3.	Collection of schedules of different tariff (rates)	10%
4.	Observations and Calculations	20%
<b>Product related: 10 Marks</b>		<b>40%</b>
5.	Interpretation of result and Conclusion	20%
6.	Answer to sample Questions	10%
7.	Prompt Submission of completed report	10%
<b>Total(25 Marks)</b>		<b>100%</b>

***Names of the Team Members:***

1. ....
2. ....
3. ....
4. ....

Marks Obtained			Date and signature of course teacher
Process Related (15)	Product Related (10)	Total (25)	



**Practical No. 8: To interpret the energy bill of a residential consumer, suggest suitable tariff to achieve energy conservation and reduction in energy bill.**

**I. Practical Significance**

The electrical diploma engineers are able to analyze the electric bill and the tariff schedule of the residential consumer and expected to suggest suitable tariff applicable to achieve energy conservation and its impact to reduce his/her energy bill.

**II. Relevant Program Outcomes (POs)**

- **Discipline knowledge:** Apply Electrical engineering knowledge to solve broad-based electrical engineering related problems.
- **Engineering tools:** Apply relevant electrical technologies and tools with an understanding of the limitations.
- **The Engineer and society:** Assess societal, health, safety, legal and cultural issues and the consequent responsibilities relevant to practice in field of electrical engineering.
- **Environment and Sustainability:** Apply electrical engineering solutions also for sustainable development practice in societal and environmental contexts.
- **Ethics:** Apply ethical principles for commitment to professional ethics, responsibilities and norms of the practice also in the field of electrical engineering.
- **Communication:** Communicate effectively in oral and written form.

**III. Competency and Practical Skills**

This practical is expected to develop the skills of identifying the types of the tariff schedule applicable to the commercial consumer and select suitable tariff to achieve the goal of energy efficiency with economy.

**IV. Relevant Course Outcome**

- Interpret energy conservation policies in India
- Implement energy conservation techniques in electrical installations.

**V. Practical Outcome (PrOs)**

To interpret the energy bill of a residential consumer, suggest suitable tariff to achieve energy conservation and reduction in energy bill.

**VI. Relevant Affective domain related Outcomes (ADOs)**

- Practice energy conservation.

**VII. Minimum Theoretical Background**

Significance of the terms used in electrical power distribution and framing of tariff. Classification of consumer based on amount of energy consumption. Various types of

tariff schedule used to calculate energy bill of commercial consumer with their respective merits and demerits.

**VIII. Practical set-up/ Circuit diagram/ Work situation/Sample of electricity bill of a domestic/residential used (paste below)**

**IX. Resources Required**

- Electricity bill of residential consumer for the current/last month.
- Tariff booklet of the relevant supply company/utility.
- Different types of tariff applicable to conserve energy and its impact on reduction in energy bill.

**X. Precautions to be followed**

Identify correctly the type of tariff used in preparation of the bill.

**XI. Procedure**

1. Collect current/last month bill of residential consumer.
2. Interpret the type and structure of tariff used to calculate the electricity bill.
3. Interpret the various heads in which the cost is distributed with significance.
4. Use different types of tariffs which are applicable to the residential consumers and calculate electricity bill.

5. Compare the change in bill.
6. Suggest type of tariff.

**XII. Resources Used**

Sr. No	Resource Used	Description about Supply Utility/Type of consumer	Remark

**XIII. Actual Procedure Followed**

.....

.....

.....

.....

**XIV Observations and Calculations**

Calculation of energy bill by using tariffs as applicable to Residential consumer.

• **Prompt Billing**

Description	Amount Payable	Prompt payment Benefit in Rs	Remark/ comments
<b>Before Due date</b>			
<b>On Due Date</b>			
<b>After due Date</b>			

• **Block rate tariff**

Tariff Structure		Total units bifurcation in steps	Total cost
Unit consumption in Block	Cost/ Unit		
0-200			
201-300			
301 and above			
Total		Units:	Rs:

• **Step rate Tariff**

Tariff Structure		Total units bifurcation in steps	Total cost
Unit consumption in Steps	Cost/ Unit		
0-99			
If Exceeds 99			
If Exceeds 199			
<b>Total</b>		<b>Units:</b>	<b>Rs:</b>

Suggest proper tariff structure after analysing actual energy bill with the calculated energy bill by selecting appropriate tariff as applicable.

**XIV. Results**

.....  
 .....  
 .....  
 .....

**XV. Interpretation of Results**

.....  
 .....  
 .....  
 .....  
 .....  
 .....  
 .....

**XVI. Conclusion (Action/ decision to be taken based on interpretation of result)**

.....  
 .....  
 .....  
 .....  
 .....



**XVIII. References/ Suggestions for further reading**

- [www.mahadiscom.com](http://www.mahadiscom.com).
- [www.bestundertaking.com](http://www.bestundertaking.com)
- [www.mercindia.org.in](http://www.mercindia.org.in)
- [www.tatapower.ddl.com](http://www.tatapower.ddl.com)
- [www.bescom.org](http://www.bescom.org)

**XIX. Suggested Assessment Scheme**

Performance Indicators		Weightage in %
<b>Process related: 15 Marks</b>		<b>60%</b>
1.	Collection of bill	10%
2.	Interpret tariff schedule for given bill	10%
3.	Selection and calculation of bill with other schedule of tariff rate	20%
4.	Observations and Calculations	20%
<b>Product related: 10 Marks</b>		<b>40%</b>
5.	Interpretation of result and Conclusion	20%
6.	Answer to sample Questions	10%
7.	Prompt Submission of completed report	10%
<b>Total (25 Marks)</b>		<b>100%</b>

*Names of the Team Members:*

1. ....
2. ....
3. ....
4. ....

Marks Obtained			Date and signature of course teacher
Process Related (15)	Product Related (10)	Total (25)	



## **Practical No. 9: Estimate the Energy saving by improving power factor and load factor.**

### **I. Practical Significance**

The electrical Electrical Engineers are expected to estimate the impact of power factor and load factor on energy consumption and its cost. They must be able to suggest the ways by which the load factor and power factor can be improved.

### **II. Relevant Program Outcomes (POs)**

- **Discipline knowledge:** Apply Electrical engineering knowledge to solve broad-based electrical engineering related problems.
- **Engineering tools:** Apply relevant electrical technologies and tools with an understanding of the limitations.
- **The Engineer and society:** Assess societal, health, safety, legal and cultural issues and the consequent responsibilities relevant to practice in field of electrical engineering.
- **Environment and Sustainability:** Apply electrical Engineering solutions also for sustainable development practice in societal and environmental contexts.
- **Ethics:** Apply ethical principles for commitment to professional ethics, responsibilities and norms of the practice also in the field of electrical engineering.
- **Communication:** Communicate effectively in oral and written form.

### **III. Competency and Practical Skills**

This practical is expected to develop the skills of identifying the impact of load factor and power factor on energy consumption in the industry/ firm. The student will be able to correlate the effect of the above factors on the cost of productivity and energy bill.

### **IV. Relevant Course Outcome**

- Interpret energy conservation policies in India
- Implement energy conservation techniques in electrical machines.
- Implement energy conservation techniques in electrical installations.
- Use Co-generation and relevant tariff for reducing losses in facilities.

### **V. Practical Outcome (PrOs)**

Estimate the Energy saving by Improving power factor and load factor.

### **VI. Relevant Affective domain related Outcomes (ADOs)**

- Follow safety practices.
- Practice good housekeeping.
- Practice energy conservation.



**VII. Minimum Theoretical Background**

Significance of the terms used in electrical power generation, distribution, utilisation and framing of tariff. Importance Load curve, load duration curve, load pattern of the industry and the provision of diversity of load to accommodate in off peak period.

$$\text{Load Factor} = \frac{\text{Consumption during the period (kWh)} \times 100}{\text{Demand} \times \text{Number of hours in that period.}}$$

**VIII.** Course teacher will give some problems/ Numerical on power saving by improving power factor and load factor. Discuss its impact on energy saving and cost effectiveness.

**IX. Resources Required**

1. Numerical from standard text books
2. From BEE guide.
3. Problem case study literature.

**X. Precautions to be Followed**

1. Take proper cases of load factor and power factor improvement.
2. Identify the cost effective and energy saving.
3. Analyse the impact with different values of the above factors.

**XI. Procedure**

1. Choose various numerical pertaining to energy saving by improving power factor and load factor.
2. Interpret the load profile and its need.
3. check whether load factor can be improved by:
  - i) **By maximum Demand reduction:** Reduce demand by distributing your loads over different time periods.
  - ii) **By increasing production:** Keeping the demand stable and increasing your consumption is often a cost-effective way to increase production while maximizing the use of your power.
4. Make comparative study of various cases and their interpretation.
5. Finally, this results in to reduction in average unit cost per kWh.

**XII. Resources Used**

Sr. No	Resource Used	Description about Supply Utility/Type of consumer	Remark

**XIII. Actual Procedure Followed**

.....  
.....  
.....  
.....

**XIV. Observations and Calculations**





**XIX. References/ Suggestions for further reading**

1. Guide Books no. 1 and 3 for National Certification Examination for Energy Managers and Energy Auditors
2. Energy Management and Conservation By Sharma, K. V., Venkateshaiah P

**XIX. Suggested Assessment Scheme**

Performance Indicators		Weightage in %
<b>Process related: 15 Marks</b>		<b>60%</b>
1.	Collection of problems	10%
2.	Analyses of load pattern	20%
3.	Determination of energy saving	10%
4.	Comparative studies presented.	20%
<b>Product related: 10 Marks</b>		<b>40%</b>
5.	Interpretation of result and Conclusion	20%
6.	Answer to sample Questions	10%
7.	Prompt Submission of completed report	10%
<b>Total (25 Marks)</b>		<b>100%</b>

*Names of the Team Members:*

1. ....
2. ....
3. ....
4. ....

Marks Obtained			Date and signature of course teacher
Process Related (15)	Product Related (10)	Total (25)	

**Practical No.10: Prepare a sample energy audit questionnaire for the given industrial facility.**

**I Practical Significance**

Energy audit questionnaire aims at interpreting the existing energy consumption pattern and identify the potential for energy saving. It is very important to have a well-structured questionnaire to understand the pattern of energy consumption.

**II Relevant Program Outcomes (POs)**

- **Discipline knowledge:** Apply Electrical engineering knowledge to solve broad-based electrical engineering related problems.
- **Engineering tools:** Apply relevant electrical technologies and tools with an understanding of the limitations.
- **The Engineer and society:** Asses societal, health, safety, legal and cultural issues and the consequent responsibilities relevant to practice in field of electrical engineering.
- **Environment and Sustainability:** Apply electrical Engineering solutions also for sustainable development practice in societal and environmental contexts.
- **Ethics:** Apply ethical principles for commitment to professional ethics, responsibilities and norms of the practice also in the field of electrical engineering.
- **Communication:** Communicate effectively in oral and written form.

**III. Competency and Skills**

- This practical is expected to develop the following skills for the industry identified competency: **Undertake energy conservation and energy audit.**

**IV. Relevant Course Outcome(s)**

Carryout energy audit for electrical system

**V Practical Outcome**

Prepare a sample energy audit questionnaire for the given industrial facility.

**VI. Minimum Theoretical Background**

- Location of the industry.
- Type of the Industry.
- Connected Load.
- Electrical energy consumption.

**VII. WORK SITUATION:**

Visit any nearby industry/Institution/Workshop/Residential Building and inspect it for Energy audit purpose.

**VIII Resources Required:**

Sr. No.	Name of Resource	Suggested Broad Specification	Remark
1	Audit Team	-	4-5 members
2	Name of the industry/firm	Postal Address, Mail id, Mobile Number	01

**IX Precautions to be followed:**

1. Check whether all the areas/departments of the industry has been covered.
2. Follow the safety measures throughout the visit.

**X Procedure**

1. Identify type of consumer like small scale industry/Institution/Workshop/Residential Building or any other electricity consumer premises.
2. Form audit team comprising 4 to 5 students.
3. Prepare appropriate questionnaire pertaining to the type of consumer.

**XI Resources Used**

Sr. No.	Name of Resource	Remarks (If any)

**XII Actual Procedure Followed (use blank sheet if space is not sufficient)**

.....

.....

.....

.....

.....

.....

.....

.....

.....

.....

**XIII Precautions Followed**

.....

.....

.....

.....

**XIV Observations and Calculations** (use blank sheet if space is not sufficient)

**Note: Questionnaire should be tailor made to the industry to be visited.**

**Sample Questionnaire for Industry/Commercial Premises:**

**1) General Information:**

<b>Name of the Company</b>			
<b>Contact Person &amp; Designation</b>			
<b>Address</b>			
<b>Phone No.</b>			<b>Cell No.</b>
<b>Fax No.</b>			<b>Email</b>
<b>Operation</b>		<b>One/Two/Three Shifts per day &amp; 6/7 days per week</b>	
<b>Fuel Consumption (per month) for DG set.</b>			
<b>Description</b>	<b>Unit Rate</b>	<b>Consumption</b>	<b>Total Amount</b>
<b>Fuel 1</b>			
<b>Fuel 2</b>			
<b>Fuel 3</b>			
<b>Electricity Bill Detail (If possible, please attach a copy of the recent bill)</b>			
<b>Connected Load, KVA</b>		<b>Contract Demand, kVA</b>	
<b>Actual Demand, kVA</b>		<b>Power Factor</b>	
<b>Type of supply</b>			
<b>Power (Minimum of Six month) Consumption, kWh/ month</b>	<b>KWH</b> Month- 1: Month- 2: Month- 3: Month- 4: Month- 5: Month- 6:	<b>Tariff structure and schedule rate</b>	<b>Total Amount, Rs.</b>



**2) Lighting Load Details:**

Sr. N O	Type of lighting fixtures	Ballas t type	Qty .	Power Rating	Operating hours

**3) Data collection of various appliances/Machines**

**A: Motors: (Use similar sheets for different motors)**

Facility/Location: \_\_\_\_\_

Department: \_\_\_\_\_

Process and Nature of Load: \_\_\_\_\_

Motor Type: \_\_\_\_\_

Motor Purchase Date / Age : \_\_\_\_\_

Coupling Type: \_\_\_\_\_

Method of starting \_\_\_\_\_

Duty Cycle \_\_\_\_\_

Rewound \_ Yes \_ No

Motor Nameplate Data/ History

1. Manufacturer: \_\_\_\_\_

2. Motor ID Number: \_\_\_\_\_

3. Rating in (HP/ kW): \_\_\_\_\_

4. Enclosure Type: \_\_\_\_\_

5. Synchronous Speed (RPM) : \_\_\_\_\_

6. Full-Load Speed (RPM) : \_\_\_\_\_

7. Voltage Rating: \_\_\_\_\_

8. Full-Load current: \_\_\_\_\_

9. Full-Load Power Factor: \_\_\_\_\_

10. Full-Load Efficiency (%) \_\_\_\_\_

11. Insulation Class: \_\_\_\_\_

4) Electrical Utility:

Equipment	Capacity/ Rating	Quantity	Operating Hrs.
Transformer	KVA, KV/ kV, A,		
Air Compressor	cfm , kg/ cm <sup>2</sup>		
Refrigeration system / Chillers	TR,		
Cooling Tower	TR		
Other			

5) D.G.Set Details:

Sr. No.	D.G.Set capacity	Qty.	Operating Hours	HSD

6) Thermal Load Details:

Sr. No	Thermal Load	Capacity	Fuel Used	Fuel Consumption Rate (Kg/day)	Operating Hrs. (per day).
		Kg/ cm <sup>2</sup>	HSD		
	Dryer				
	Oven				
	Hot Air Generator				

**7) Environmental condition (geographical details)**

**8) Additional Information (if any)**

**XV Results**

.....  
.....  
.....  
.....

**XVI. Interpretation and selection of questionnaire based on the type of industry/firm.**

.....  
.....  
.....  
.....

**XVII. Conclusions** (Actions/decisions to be taken to plan and prepare the questionnaire to collect maximum information)

.....  
.....  
.....  
.....

**XVIII. Practical Related Questions**

*Note: Below given are few sample questions for reference. Teachers **must design more such questions so as to ensure the achievement of identified CO.***

1. List out the different types of consumers.
2. Write the importance of developing questionnaire for energy audit.

(Space for Answer)

.....  
.....  
.....  
.....  
.....  
.....  
.....  
.....  
.....  
.....  
.....  
.....  
.....  
.....  
.....  
.....  
.....  
.....  
.....  
.....  
.....



**XIX. References / Suggestions for Further Reading**

1. [www.bee\\_india.nic.in](http://www.bee_india.nic.in)
2. [www.worldenergy.org](http://www.worldenergy.org)
3. <http://www.pcra.org/pages/display/180-Energy-Audit>

**XX. Assessment Scheme**

<b>Performance Indicators</b>		<b>Weightage in %</b>
<b>Process related: 15 Marks</b>		<b>60%</b>
1	Identification of Industry	10 %
2	Identification of areas	20 %
3	Preparation of questionnaire	20 %
4	Working in team	10 %
<b>Product related:10 Marks</b>		<b>40%</b>
	Demarcation of areas	10 %
2	Demarcation of apparatus	10 %
3	Conclusions	05 %
4	Practical related questions	10 %
5	Submitting the journal in time	05%
<b>Total (25 Marks)</b>		<b>100 %</b>

*Names of Student Team Members*

1. ....
2. ....
3. ....
4. ....

<b>Marks Obtained</b>			<b>Date and signature of course teacher</b>
<b>Process Related (15)</b>	<b>Product Related (10)</b>	<b>Total (25)</b>	

## **Practical No.11(a): Prepare an energy audit report (phase-I, Walkthrough Audit)**

### **I. Practical Significance**

An energy audit is a systematic procedure that aims to obtain an adequate knowledge of the energy consumption of a building or an industrial plant. It also aims to identify and evaluate the cost-effective energy saving opportunities. The energy audit practice is aimed to prepare the students of diploma engineering to understand the significance of energy audit and cost effective implementation to benefit the firm/ society they serve.

### **II. Relevant Program Outcomes (POs)**

- **Discipline knowledge:** Apply Electrical engineering knowledge to solve broad-based electrical engineering related problems.
- **Engineering tools:** Apply relevant electrical technologies and tools with an understanding of the limitations.
- **The Engineer and society:** Asses societal, health, safety, legal and cultural issues and the consequent responsibilities relevant to practice in field of electrical engineering.
- **Environment and Sustainability:** Apply electrical Engineering solutions also for sustainable development practice in societal and environmental contexts.
- **Ethics:** Apply ethical principles for commitment to professional ethics, responsibilities and norms of the practice also in the field of electrical engineering.
- **Communication:** Communicate effectively in oral and written form.

### **III. Competency and Skills**

- This practical is expected to develop the following skills for the industry identified competency: **Undertake energy conservation and energy audit.**

### **IV. Relevant Course Outcome(s)**

- Implement energy conservation techniques in electrical machines.
- Apply energy conservation techniques in electrical installations.
- Use Co-generation and relevant tariff for reducing losses in facilities.
- Carryout energy audit for electrical system.

### **V. Practical Outcome**

Prepare an energy audit report (phase-I):Scheduling an Energy Audit - Collection of Primary

Data & preliminary interpretation of energy data by walk through audit.

**VI. Minimum Theoretical Background**

1. Total connected load, Nature of load, Duty cycle, Understand the electrical plan layout.
2. Energy bill comprises of cost of maximum demand charges (fixed), energy consumption charges (variable), and also penalty for low power factor.
3. Also energy charge includes a component based on time of use.

**VII. Practical set-up/ Circuit diagram /Work Situation**

Survey Industry/ Institution where energy audit is to be carried out.



**VIII. Resources Required**

Sr. No.	Name of Resource	Suggested Broad Specification	Quantity
1	Questionnaire along with answers obtained by informal interview & Survey		1 set
2	Electricity Bills		1 set comprising of 12 monthly bills
3	Apparatus to measure different quantities		1 each
4	Supervisor/shift in-charge		

**IX. Precautions to be followed:**

1. During inspection, apart from the visual inspection, check the condition of the electrical installation, opportunity for use of Natural light.
2. Follow the safety measures throughout the visit.
3. Load is segregated based on end use, such as lighting & fan load, air conditioning load, water pumping, computers & printers, any other load which uses electricity.
4. The accurate temperature measurement is very vital in refrigeration and air conditioning. All instruments, including gauges and thermometers shall be calibrated over the range of test readings for the measurement of all parameters.

**X. Procedure**

1. Visit the industry along with the team.
2. Organize an informal interview with the plant manager/ energy manager if required.
3. Familiarize yourself with plant activities.
4. Collect the information as per the questionnaire prepared in the previous practical..
5. Confirm/ Assure that all the relevant information necessary to carry out the audit of the plant have been covered.
6. Collect monthly energy bill of the industry for the last one year.
7. Analyze and plot energy consumption pattern from energy bill.

**XI. Resources Used**

Sr. No.	Name of Resource	Broad Specifications	Quantity	Remarks (If any)

Sr. No.	Name of Resource	Broad Specifications	Quantity	Remarks (If any)

**XII. Actual Procedure Followed (use blank sheet if space is not sufficient)**

.....  
.....  
.....  
.....

**XIII. Precautions Followed**

.....  
.....  
.....  
.....

**Observations and Calculations (use blank sheet if space is not sufficient)**

**Name of Industry/workshop/Institution:**

**Name OF Contact Person:**

**Designation:**

**Mobile Number:**

**Address of Company:**

**Tel. No. :**

**Fax. No. :**

**E mail:**

**Preparation of Data sheets:**

**1. Past 12 Months' Electricity Bills (Enclose Photo Copy of bills )**

Month	kWh charges	M.D. charges	P.F incentive /penalty.	Rs. /kWh	Bill in Rs.
	<b>A</b>	<b>b</b>	<b>c</b>		<b>a+b+or-c</b>
Jan					
Feb					
Mar					
Apr					
May					
Jun					
July					
Aug					
Sep.					
Oct.					
Nov.					
Dec.					
<b>Total</b>					

**2. Assessment of existing Lighting System:**

**i. Lamp and Ballast Details:**

Sr. No.	Plant Location	Lighting Device & Ballast Type	Rating in watts Lamp & Ballast	Quantity in numbers	Operating Hours/ day

**ii. Details of Lighting Transformer (If provided):**

Sr. No.	Plant Location	Lighting Transformer Rating	Quantity	Meter Provision available Volts / Amps / kW / Energy

**iii. Illumination Measurement:**

Sr. No	Plant Location	Day Time Lux Average Level	Night Time Lux Average Level	Recommended Illumination level as per IS	Remarks

**3. Assessment of Existing Air conditioning & Refrigerating System:**

Sr.No	Capacity in Tons& Star rating & Type of Unit	Specific Power consumption	Operational hours	Frequency of Maintenance of the Compressor

**4. Transformer details**

**Transformer Name Plate Details**

- Transformer Rating :
- Transformer Make :
- Transformer Serial No. :
- Transformer Voltage Rating: HV/LV
- Transformer Taps :
- Transformer Current Rating: HC/LC
- % Voltage Impedance:
- Year of Manufacturing

**5. Details of Motors:**

<b>Sr. No.</b>	<b>Location</b>	<b>Type of the Motor</b>	<b>Rating of Motor</b>	<b>Percentage Load</b>	<b>Operating Hours/month</b>	<b>Any Maintenance issues?</b>

**6. Any other Load:**

**XIV. Results**

.....  
.....  
.....  
.....

**XV. Interpretation of Data (Write whether the data collected is sufficient to carry out energy audit, if required collect additional data.)**

.....  
.....  
.....  
.....

**XVI. Conclusions (Actions/decisions to be taken based on the interpretation of data.)**

.....  
.....  
.....  
.....

**XVII. Practical Related Questions**

*Note: Below given are few sample questions for reference. Teachers **must design** more such questions so as to ensure the achievement of identified CO.*

1. Define walk through audit and state its significance.
2. State the factors considered while collecting the information.
3. State the various methods of data collection related to energy audit.

**(Space for Answer)**

.....  
.....  
.....  
.....  
.....  
.....  
.....  
.....  
.....  
.....  
.....  
.....  
.....  
.....  
.....  
.....  
.....  
.....  
.....  
.....  
.....



**XVIII. References / Suggestions for Further Reading**

1. [www.bijlibachao.com](http://www.bijlibachao.com)
2. [www.bee\\_india.nic.in](http://www.bee_india.nic.in)
3. [www.worldenergy.org](http://www.worldenergy.org)
4. <http://www.pcra.org/pages/display/180-Energy-Audit>

**XIX. Assessment Scheme**

Performance Indicators		Weightage
<b>Process related: 15 Marks</b>		<b>60%</b>
1	Industry survey and data search	10 %
2	Analyzing existing energy consumption	20 %
3	Preparation of datasheet	20 %
4	Working in team	10 %
<b>Product related:10 Marks</b>		<b>40%</b>
1	Noting the results	05 %
2	Interpretation of results	10 %
3	Conclusions	10 %
4	Practical related questions	10 %
5	Submitting the journal in time	05%
<b>Total (25 Marks)</b>		<b>100 %</b>

*Names of Student Team Members*

1. ....
2. ....
3. ....
4. ....

Marks Obtained			Dated signature of Teacher
Process Related (15)	Product Related (10)	Total (25)	



## **Practical No.11(b): Prepare an energy audit report (phase-II)**

### **I. Practical Significance**

During this stage, a qualitative investigation of the building and the installations is performed, and the findings are tabulated in a specific form. This data collection along with the instantaneous sampling of measurements helps to find energy use and thus leads to the knowledge of energy balance of the building.

### **II. Relevant Program Outcomes (POs)**

- **Discipline knowledge:** Apply Electrical engineering knowledge to solve broad-based electrical engineering related problems.
- **Engineering tools:** Apply relevant electrical technologies and tools with an understanding of the limitations.
- **The Engineer and society:** Asses societal, health, safety, legal and cultural issues and the consequent responsibilities relevant to practice in field of electrical engineering.
- **Environment and Sustainability:** Apply electrical Engineering solutions also for sustainable development practice in societal and environmental contexts.
- **Ethics:** Apply ethical principles for commitment to professional ethics, responsibilities and norms of the practice also in the field of electrical engineering.
- **Communication:** Communicate effectively in oral and written form.

### **III. Competency and Skills**

- This practical is expected to develop the following skills for the industry identified competency: **Undertake energy conservation and energy audit.**

### **IV. Relevant Course Outcome(s)**

- Implement energy conservation techniques in electrical machines.
- Apply energy conservation techniques in electrical installations.
- Use Co-generation and relevant tariff for reducing losses in facilities.
- Carryout energy audit for electrical system.

### **V. Practical Outcome**

Prepare an energy audit report (phase-II).*Energy Data Analysis*

### **VI. Minimum Theoretical Background**

- Rating of electrical equipment.
- Energy consumption of equipment.
- Connected loads.
- Existing tariff structure.

**VII. Practical set-up/ Circuit diagram /Work Situation**

**VIII. Resources Required**

<b>Sr. No.</b>	<b>Name of Resource</b>	<b>Suggested Broad Specification</b>	<b>Quantity</b>
1	Data collected from previous practicals		
2	Various energy conservation techniques from BEE book		
3	Technical articles from Journals		
4	Energy Efficient Apparatus pamphlets.		

**IX. Care to be taken /Precautions to be followed:**

1. Check whether all the areas/departments of the industry have been considered for energy conservation.
2. Select economical and viable energy conservation techniques considering consumer's budget.
3. Consider the safety measures while suggesting the energy conservation techniques.

**X. Procedure**

1. Prepare a data sheet showing the entire load along with their existing energy consumption.( By using the data collected in walk through audit)
2. Identify the areas for opportunities of energy conservation.
3. Identify the energy conservation techniques for adaption.
4. Estimate the energy consumption after the adaption of identified energy conservation techniques.

**X. Resources Used**

Sr. No.	Name of Resource	Suggested Broad Specification	Quantity

**XII. Actual Procedure Followed** (use blank sheet if space is not sufficient)

.....

.....

.....

.....

.....

.....

.....

.....

.....

.....

.....

.....

.....

.....

.....

**XIII. Precautions Followed**

.....

.....

.....

.....

**XIV. Observations and Sample Calculations** (use blank sheet if space is not sufficient)

**Table A:**

Energy Consumption of Existing Installation:

Sr. No.	Name of the Equipment/ Device	Rating kW	Quantity Nos.	Total Power in kW	Operating Hours in a day	Energy consumed per day kWh	Energy consumed per month, kWh
Total Energy Consumption For a month in kWh							

**Table B:**

Energy Consumption with energy conservation techniques

Sr. No.	Name of the Energy efficient Equipment/ Device	Rating kW	Quantity Nos.	Total Power in kW	Operating Hours in a day	Energy consumed per day kWh	Energy consumed per month, kWh

Total Energy Consumption For a month in kWh							

**XV. Results**

.....

.....

.....

.....

**XVI. Interpretation of Results (Write meaning of the above obtained results)**

.....

.....

.....

.....

**XVII. Conclusions (Actions/decisions to be taken based on the interpretation of results)**

.....

.....

.....

.....

**XVIII. Practical Related Questions**

*Note: Below given are few sample questions for reference. Teachers **must design** more such questions so as to ensure the achievement of identified CO.*

1. State energy conservation technique impact on society and environment.
2. List the energy audit instruments which can be used to collect actual data for energy audit project.

**(Space for Answer)**

.....

.....

.....

.....

.....

.....

.....

.....

.....



**XIX. References / Suggestions for Further Reading**

1. [www.energyrating.gov.au/](http://www.energyrating.gov.au/)
2. [www.bijlibachao.com](http://www.bijlibachao.com)
3. [www.bee\\_india.nic.in](http://www.bee_india.nic.in)
4. [www.worldenergy.org](http://www.worldenergy.org)
5. <http://www.pcra.org/pages/display/180-Energy-Audit>

**XX. Assessment Scheme**

Performance Indicators		Weightage
<b>Process related: 15 Marks</b>		<b>60%</b>
1	Industry survey and Data search	10 %
2	Calculation of existing Energy Consumption	20 %
3	Preparation of datasheet	20 %
4	Working in team	10 %
<b>Product related:10 Marks</b>		<b>40%</b>
1	Noting the results	05 %
2	Interpretation of results	10 %
3	Conclusions	10 %
4	Practical related questions	10 %
5	Submitting the journal in time	05%
<b>Total (25 Marks)</b>		<b>100 %</b>

*Names of Student Team Members*

1. ....
2. ....
3. ....
4. ....

Marks Obtained			Date and signature of course teacher
Process Related (15)	Product Related (10)	Total (25)	

## **Practical No.11(c): Prepare an energy audit report (phase-III)**

### **I. Practical Significance**

After verification & monitoring of energy use in phase I and phase II of energy audit, Analysis of use of energy is a final and important phase in conduction of energy audit. This includes the submission of technical report containing recommendations for improving energy efficiency with cost benefit analysis and an action plan to reduce energy consumption.

### **II. Relevant Program Outcomes (POs)**

- **Discipline knowledge:** Apply Electrical engineering knowledge to solve broad-based electrical engineering related problems.
- **Engineering tools:** Apply relevant electrical technologies and tools with an understanding of the limitations.
- **The Engineer and society:** Assess societal, health, safety, legal and cultural issues and the consequent responsibilities relevant to practice in field of electrical engineering.
- **Environment and Sustainability:** Apply electrical Engineering solutions also for sustainable development practice in societal and environmental contexts.
- **Ethics:** Apply ethical principles for commitment to professional ethics, responsibilities and norms of the practice also in the field of electrical engineering.
- **Communication:** Communicate effectively in oral and written form.

### **III. Competency and Skills**

- This practical is expected to develop the following skills for the industry identified competency: **Undertake energy conservation and energy audit.**

### **IV. Relevant Course Outcome(s)**

- Interpret energy conservation policies in India.
- Implement energy conservation techniques in electrical machines.
- Apply energy conservation techniques in electrical installations.
- Use Co-generation and relevant tariff for reducing losses in facilities.
- Carryout energy audit for electrical system.

### **V. Practical Outcome**

Prepare energy audit report (phase-III)



**VI. Minimum Theoretical Background**

- Objectives of audit
- Types of energy audit
- Procedure of energy audit
- Information about energy audit instruments.

**VII. Practical set-up/ Circuit diagram /Work Situation**

Data sheets prepared at the previous phases of audit.

**VIII. Resources Required**

<b>Sr. No.</b>	<b>Name of Resource</b>	<b>Suggested Broad Specification</b>	<b>Quantity</b>
1	Results obtained in the previous practicals		
2	Pamphlets of Energy efficient devices with their cost in Rupees		

**IX. Precautions to be followed:**

1. While minimizing energy cost care is to be taken to see that production and quality are not compromised.
2. Once the technical report is submitted, follow up is necessary to see that energy conservation suggestions are properly implemented.

**X. Procedure**

1. Identify and develop energy conservation opportunities.
2. Assess technical feasibility, economic viability of energy conservation options for implementation.

**Technical and Economic feasibility**

The technical feasibility should address the following issues

- Technology availability, space, skilled manpower, reliability, service etc
- The impact of energy efficiency measure on safety, quality, production or process.
- The maintenance requirements and spares availability

The Economic viability often becomes the key parameter for the management acceptance. The

Economic analysis can be conducted by using a variety of methods. Example: Simple Pay back method.

3. Prepare the audit report comprising implementation of conservation techniques (with and without investment), payback period etc. and submit it to the top management.

**XI. Resources Used**

Sr. No.	Name of Resource	Broad Specifications	Quantity
1.			
2.			
3.			
4.			

**XII. Actual Procedure Followed** (use blank sheet if space is not sufficient)

.....

.....

.....

.....

.....

.....

**XIII. Precautions Followed**

.....

.....

.....

.....

**XIV. Observations and Calculations** (use blank sheet if space is not sufficient)

Summary of Energy Saving Recommendations:

Sr. No	Plant/Location	Energy Saving Recommendations	Annual Energy savings (Electricity) Savings kWh	Annual savings in Rs.	Capital Investment for energy conservation technique in Rs.	Simple pay back period

**Suggested System: Sample Calculation for energy saving Recommendation:**

**Existing System:**

**Motor Load and Efficiency Determination**

**Operating Load** \_\_\_\_\_  
 Input Power (kW) / [Motor Size (hp) x 0.746 / Efficiency at Full Load

Motor Efficiency at Operating Load \_\_\_\_\_

**kW saved** \_\_\_\_\_

Input Power - [Load x hp x 0.746 / Efficiency of Replacement  
 Motor at Load Point]

**kWh saved** \_\_\_\_\_

(kW saved x Annual Operating Hours)

**Modified System**

Annual Operating Cost = Kwh consumption x energy rate/kwh = 50 lakh  
 Annual Savings = operating cost of existing system – operating cost of suggested system

Net Annual Saving =

Investment for New system =

Additional cost of installation =

**Simple Payback Period in Months = (Investment/ Net Savings) x 12**

**XV. Results**

.....  
.....  
.....  
.....

**XVI. Interpretation of Results** (Write meaning of the above obtained results)

.....  
.....  
.....  
.....

**XVII. Conclusions** (Actions/decisions to be taken based on the interpretation of results)

.....  
.....  
.....  
.....

**XVIII. Practical Related Questions**

*Note: Below given are few sample questions for reference. Teachers **must design more such questions so as to ensure the achievement of identified CO.***

1. Name the instruments used for energy audit.
2. State the use of the following instruments in audit.(a) Infrared thermometer (b) Fyrite (c) Anemometer (d) Pitot tube.
3. Name different types of energy audit.

**(Space for Answer)**

.....  
.....  
.....  
.....  
.....



**XIX. References / Suggestions for Further Reading**

1. [www.bee\\_india.nic.in](http://www.bee_india.nic.in)
2. [www.worldenergy.org](http://www.worldenergy.org)

**XX. Assessment Scheme**

<b>Performance Indicators</b>		<b>Weightage</b>
<b>Process related: 15 Marks</b>		<b>60%</b>
1	Recommendation of New EC techniques	10 %
2	Preparation of cost analysis& pay back	20 %
3	Preparation of complete audit report	20 %
4	Working in team	10 %
<b>Product related:10 Marks</b>		<b>40%</b>
5	Noting the results	05 %
6	Interpretation of results	10 %
7	Conclusions	10 %
8	Practical related questions	10 %
9	Submitting the report in time	05%
<b>Total (25 Marks)</b>		<b>100 %</b>

*Names of Student Team Members*

1. ....
2. ....
3. ....
4. ....

<b>Marks Obtained</b>			<b>Date and signature of course teacher</b>
<b>Process Related (15)</b>	<b>Product Related (10)</b>	<b>Total (25)</b>	

**Practical No.12: Determination of rating of Inverter capacity for household applications**

**I Practical Significance**

Every Electrical Engineer must have the knowledge of energy consumption of electrical appliances he/she is using. Identification of suitable star labeled appliance helps in comparison of energy efficiency, running cost while purchasing new machine/equipment. Also efficient appliance reduces carbon emission thus protecting our environment.

**II Relevant Program Outcomes (POs)**

- **Discipline knowledge:** Apply Electrical Engineering knowledge to solve broad based Electrical Engineering related problems.
- **Environment and sustainability:** Apply Electrical engineering solutions also for sustainable development practices in societal and environmental contexts.
- **Engineering tools:** Apply relevant Electrical technologies and tools with an understanding of the limitations.
- **Ethics:** Apply ethical principles for commitment to professional ethics, responsibilities and norms of the practice also in the field of electrical engineering.
- **Communication:** Communicate effectively in oral and written form.

**III Relevant program specific Outcomes (PSOs)**

- Maintain various types of rotating and static electrical equipment.

**IV Competency and Skills**

- This practical is expected to develop the following skills for the industry identified competency: **Undertake energy conservation and energy audit.**

**V Relevant Course Outcome(s)**

- Interpret energy conservation policies in India.
- Implement energy conservation techniques in electrical machines.

**VI. Practical Outcome**

- **Analyze star labeled electrical apparatus and compare the data sheet (Pamphlet) of various star ratings.**

**VII. Minimum Theoretical Background**

- Construction & working of different types of electrical appliances.
- Interpretation of the features with their technical specifications.
- Size/Rating of electrical equipment.
- Energy consumption of equipment.

**VIII** Course teacher will give some problems / Numerical on load calculation.so that the Desired capacity of inverter can be suggest.

**IX. Resources Required**

1. Numerical from standard text books
2. Different load specifications and its ratings

**X. Precautions to be Followed**

1. Take proper loads and its specifications
2. Calculate total load and Then Total VA.
3. Finally, Suggest the rating of Inverter and battery backup time if necessary.

**XI Resources Used**

S.No	Name of the source	Rating	Remarks
1			
2			
3			
4			
5			
6			
7			
8			

**XII Observations and Calculations**



**XIV. Results**

.....  
.....  
.....  
.....

**XV. Interpretation of Results**

.....  
.....  
.....  
.....

**XVI. Conclusion (Action / decision to be taken based on interpretation of result)**

.....  
.....  
.....  
.....

**XVII. Practical Related Questions**

1. What is Electrical Load?
2. What are the types of electrical Loads?
3. What are the examples for Unity power factor Load?
4. What is Inverter?
5. What is Converter?

**(Space for Answers)**